



# Table of Contents

**Section**

# 1B

## Technical Schematics

Frequently Asked Electrical Questions	1B-2
Harness/Schematic Location Information	1B-3
47/48/49/69 Main Chassis Harness Schematic	1B-4
Chassis Harness Break Out Locations	1B-5
Chassis Max Complexity Harness	
All LHD EPA 2010 Models: Front Wall Fwd	1B-6
All LHD EPA 2010 Models: Under Cab Rear	1B-7
4700/4800/4900/6900 Main Cab Schematic	1B-8
4700/4800/4900 LHD PTO Schematic	1B-9
4800/4900 LHD PTO Schematic	1B-10
4800/4900 Remote Fast Idle	1B-11
4800/4900 Remote Start Stop	1B-12
48/49/69 Engine Remote Interface - EOF	
End of Frame Engine Remote Interface - 148-071	1B-13
End of Frame Engine Remote Interface - 148-035	1B-14
Exterior Cab Body Builder Connections	1B-15
4800/4900/6900 Plow Light Prep	1B-16
4700 10 AMP Switches & In Cab Connections	1B-17
4700 Body Builder Cab Access Port	1B-18
4700 Body Builder Interface	1B-19
Speed Sensor Connections Interface	1B-20

This guide is to be used as a reference document only. Please consult your Western Star CAE representative on specific spec'ing needs as the information contained in this document can change without notice.



# Frequently Asked Electrical Questions

**Question:** How can I tell from the order if the truck has any body builder connections?

**Answer:** Look at **sales code 334** and **353** to determine if supplemental body builder harness options were ordered with your truck.

**Question:** If there is a Body Builder option, what type of interface plug does the option have and where will it be located?

**Answer:** The 4700 offers blunt cut wires at the BOC with an access plate in the floor for body builder connections see page **1A-13/14** and **1B-18/19**. The 4800/4900/6900 offer body builder harnesses to the exterior BOC and the End of Frame with std plugs. See page **1B-14** for schematics and details.

**Question:** Where can I find specific transmission information on the truck order and in the Body builder book?

**Answer:** Truck specific Transmission specifications can be located in the truck order under sales code **342** and schematic information can be found using the sales codes found on page **1B-4** of this chapter of the body builder book.

**Question:** Can you obtain wiring diagrams for specific options for serial numbers and any information on dealer optionally installed features?

**Answer:** Specific schematic information can be obtained by serial number is available to our dealers on line via PartsPro and EZ wiring. Use page **1B-4** of this chapter to locate the module location information.

**Question:** Does Western Star utilize the (J1939) CAN-bus data protocol?

**Answer:** The Western Star dash gauges and driver display (if equipped) are controlled via the J1587 data bus. See the star gauge **P 1A-6, 1A-7** for more information.

**Question:** Can the day time running lights be deactivated?

**Answer:** The instructions to deactivate the day time running lights are located on page **1A-22**.

**Question:** Is there a high amperage option for Plow lights on the 4800/4900/6900 Models?

**Answer:** Yes a plow light package is available using Sales code **329-054** which supplies a separate junction box mounted to the back wall behind the passenger seat. See details and schematics for this option on **page 1B-16**.

**Question:** Is there a place I can tie into the tail lights without splicing into the tail light harness?

**Answer:** Yes some trucks will be equipped with a capped plug at the bac of cab LH rail that is labeled supplemental trailer cable wiring (shown on **P 1B-15**) if the **388 Mod** option has ordered. If this option and plug is not in the harness **Pins #20,33,44,57** and **71** can be been accessed in the Main Chassis Bulkhead. The pinout details for this plug can be found in **page 1C-4** dependant on your model and production year.

**Question:** I have a unit with a Eaton manual transmission. Where would the body builder locate the vehicle speed when installing a salt/sander spreader with a controlled flow rate at different speeds on a manual transmission?

**Answer:** The best way to do this is by adding a second speed sensor to the rear bearing cover of the transmission. see Page **1B-20**.

**Question:** Is a J1939 Protocol available? If so, how can I gain access to it?

**Answer:** With the 2010 model year trucks or newer the J1939 protocol is available via the diagnostic connector located at the lower left hand side of the dash and new nodes can be added at the end resistors. See Page **1A-10** and **1A-11** for location and connection details.

**Question:** Is there any factory provisions for remote Stop?

**Answer:** Yes remote Stop is available using Option code **162-018** based on the engine configuration. Availability would need to be determined by the Sales and Application Engineering groups.

**Question:** Is there any factory provisions for remote Start/Stop?

**Answer:** Yes remote Start Stop is available using Option code **157-004** for the 4800/4900 models. Customer supplied harness with 4 position switch is supplied by customer for this option See **Page 1B-12** for more details.

**Question:** How do I get remote Engine Speed Control (ECU)?

**Answer:** This option can be requested on new orders via data code **163-008** or **163-009**. If these options are not present, remote engine speed control can also be accessed via the JS19 connector located in the engine compartment and is part of the main engine harness A06-63518. See Pages **1B-13** to **1B-15** for schematic information.

**Question:** Can you get a fast idle interface on the WST?

**Answer:** Data code **148-035** provides a fast idle switch interface tied to the parking brake See schematics on Page **1B-11**.

**Question:** Does the 4700 model have the same electrical architecture as the 4800/4900 models?

**Answer:** The 4700 electrical architecture is the same as other WST models but has different pin locations in the front wall. These differences are defined in the pin out charts in chapter **1C** dependant on your model and production year.

**Question:** Can you deactivate the brake override circuit so that the 4-way flashers stay on when the brakes are activated?

**Answer:** The instructions to disable the brake override circuit are located on page **1A-21**.

**Question:** I have installed aftermarket LED tail lamps to my vehicle but they are not working properly.

**Answer:** The WST electrical turn signal system requires a minimum amperage load from the tail light system. When LED lights are used a resistor needs to be added to increase the load to an acceptable level. See Page **1A-21** for installation information.

**Question:** Does WST offer switches that are ignition controlled that are not rated to 20 amps or relay controlled?

**Answer:** Yes WST offers a (6) optional switch option for this application with **329-071** see page **1A-15**.

**Question:** If I need to stop the truck from starting under specific conditions is there a way I can do this?

**Answer:** Yes, tying into the Neutral Safety switch circuit (located in the front wall PDM, see page **1A-7**) with a signal controlled relay will stop the truck from starting. the starting schematics can be found in **Mod 156** and are specific for each engine Make.



# Harness/Schematic Location Information

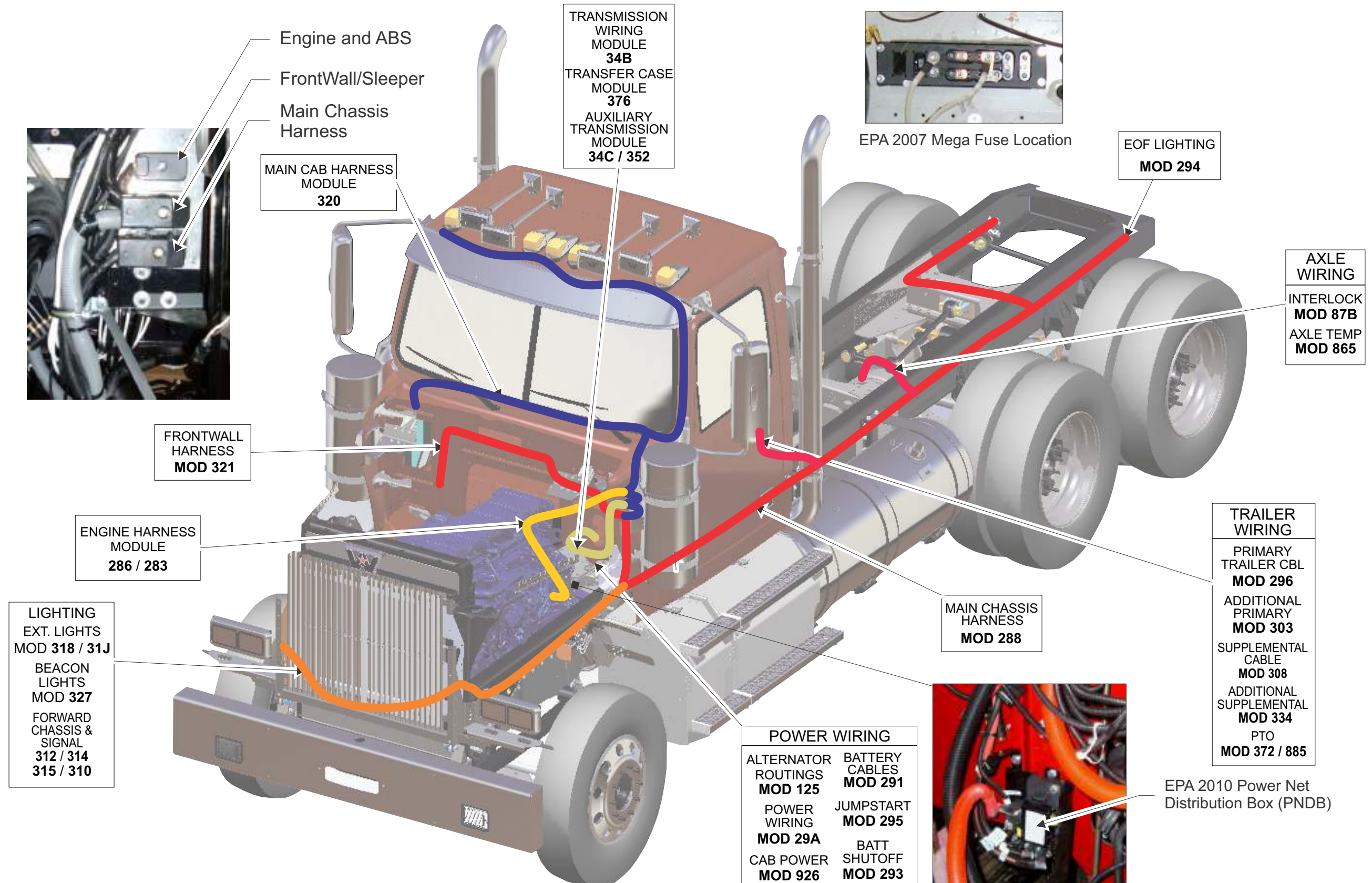



# 47/48/49/69 Main Chassis Harness Schematic

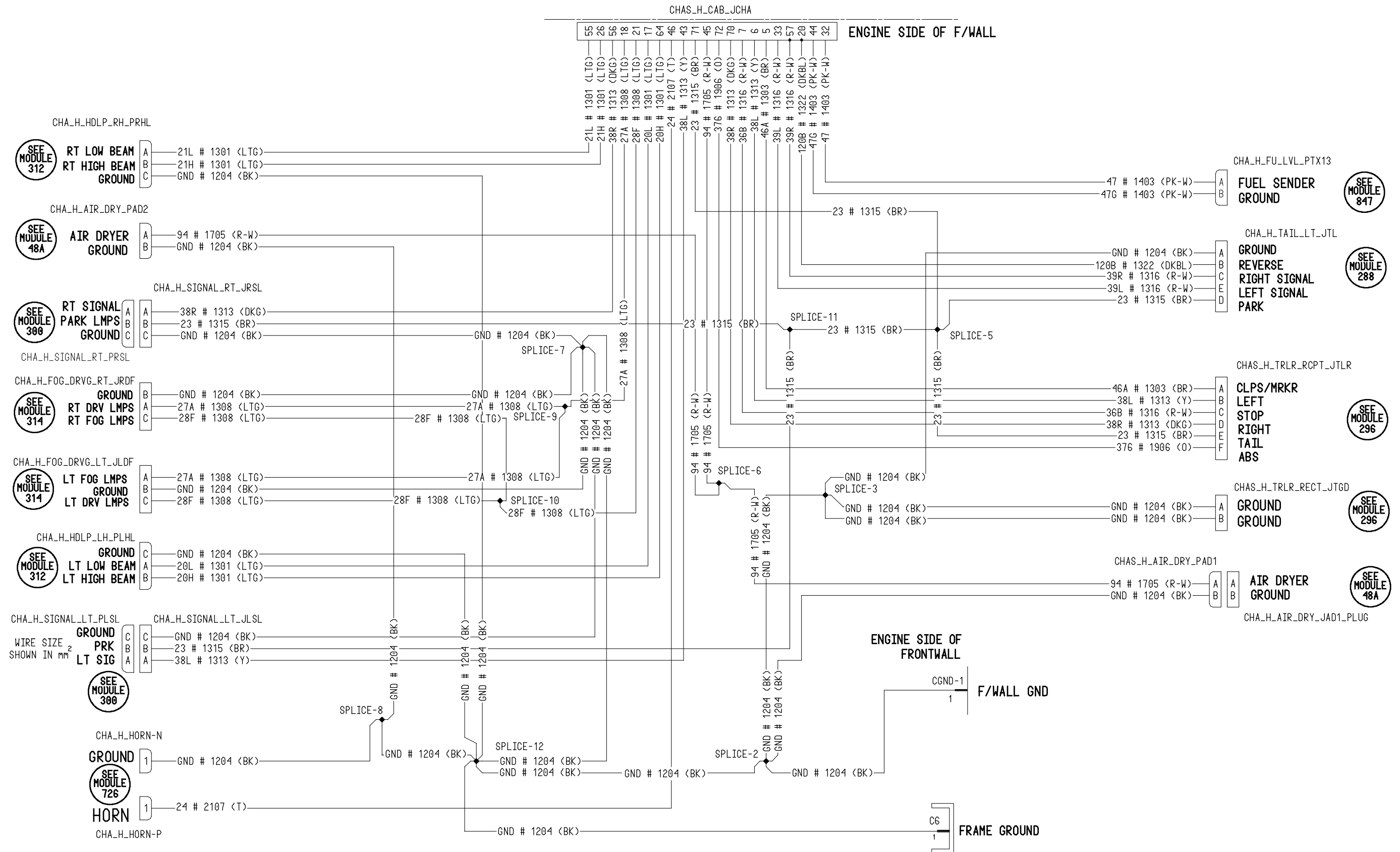



# Chassis Harness Break Out Locations

## All EPA 2010 LHD Models

### Chassis Harness Max Complexity Harness

New electrical systems for 2010 will be shown using a Max Complexity harness layout L06-82534. This new diagram system provides all possible connections that are available on one single diagram. This information provides the connector part number and the Sales Code and or Module number that the option and schematic detail can be found.

#### How to use this diagram system

- Use the diagram to locate where on the chassis the connections will be located.
- Note:** Some locations are approximate due to wheelbase differences.
- Not all connections shown in the diagram will be on any one specific vehicle.

**Note:** To order new harnesses for service or repair refer to **Parts Bulletin 54-018**.

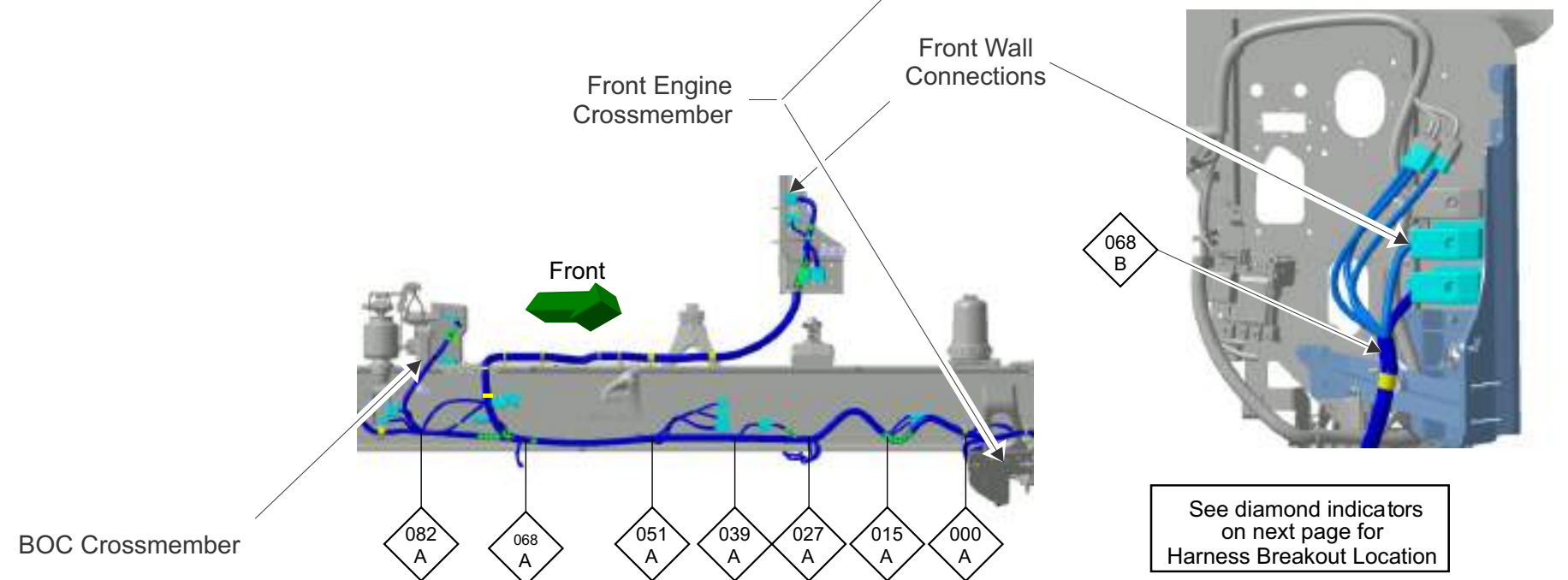
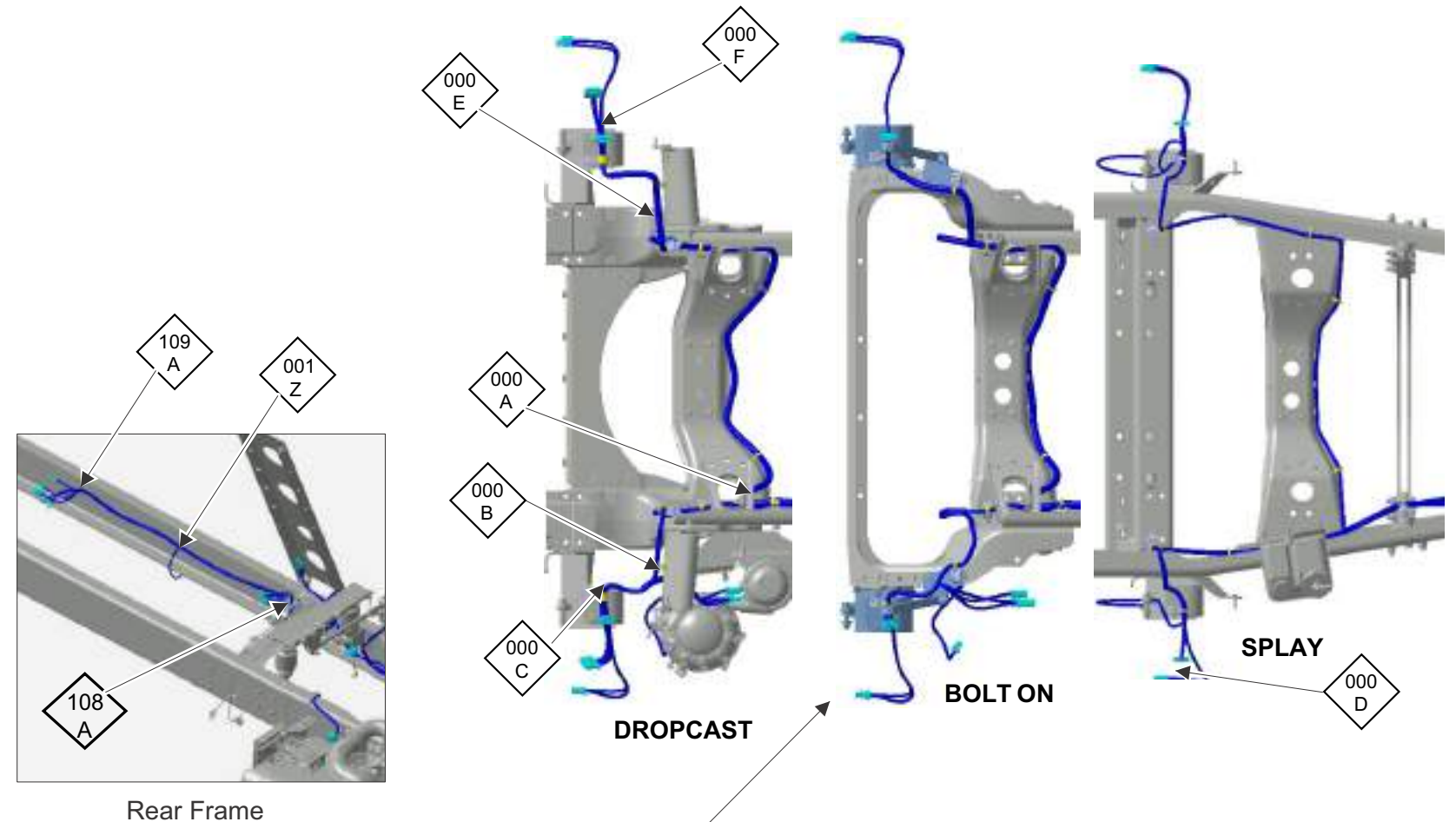
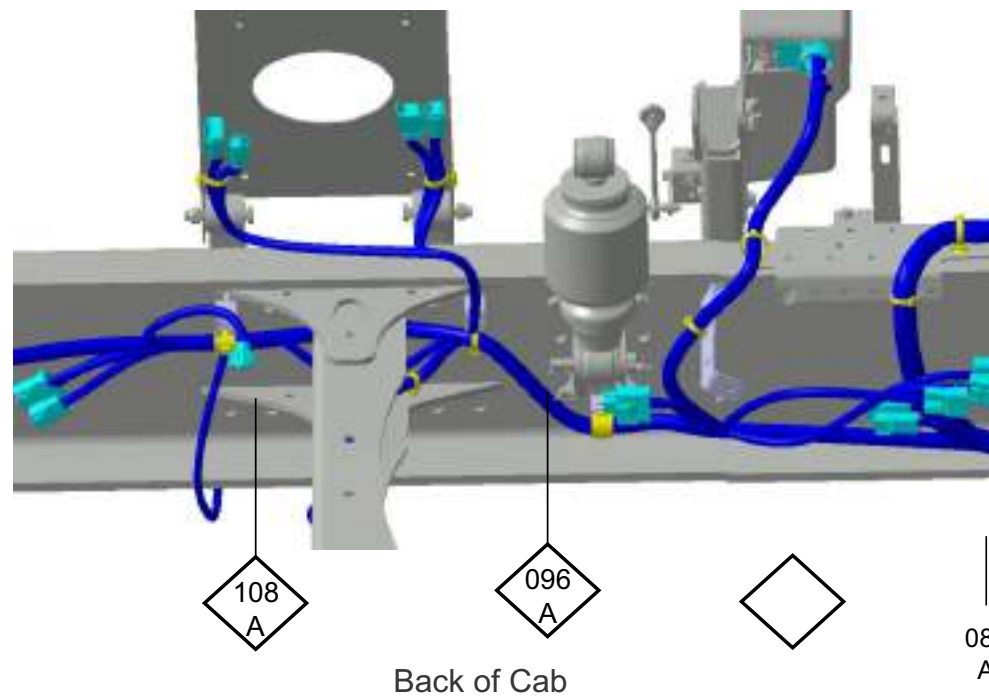

See diamond indicators on next page for Harness Breakout Location

### All LHD EPA 2010 Models: Front Wall Fwd

**Note:** Maximum complexity diagrams show all possible connections.  
All connections will never be present on any one vehicle.

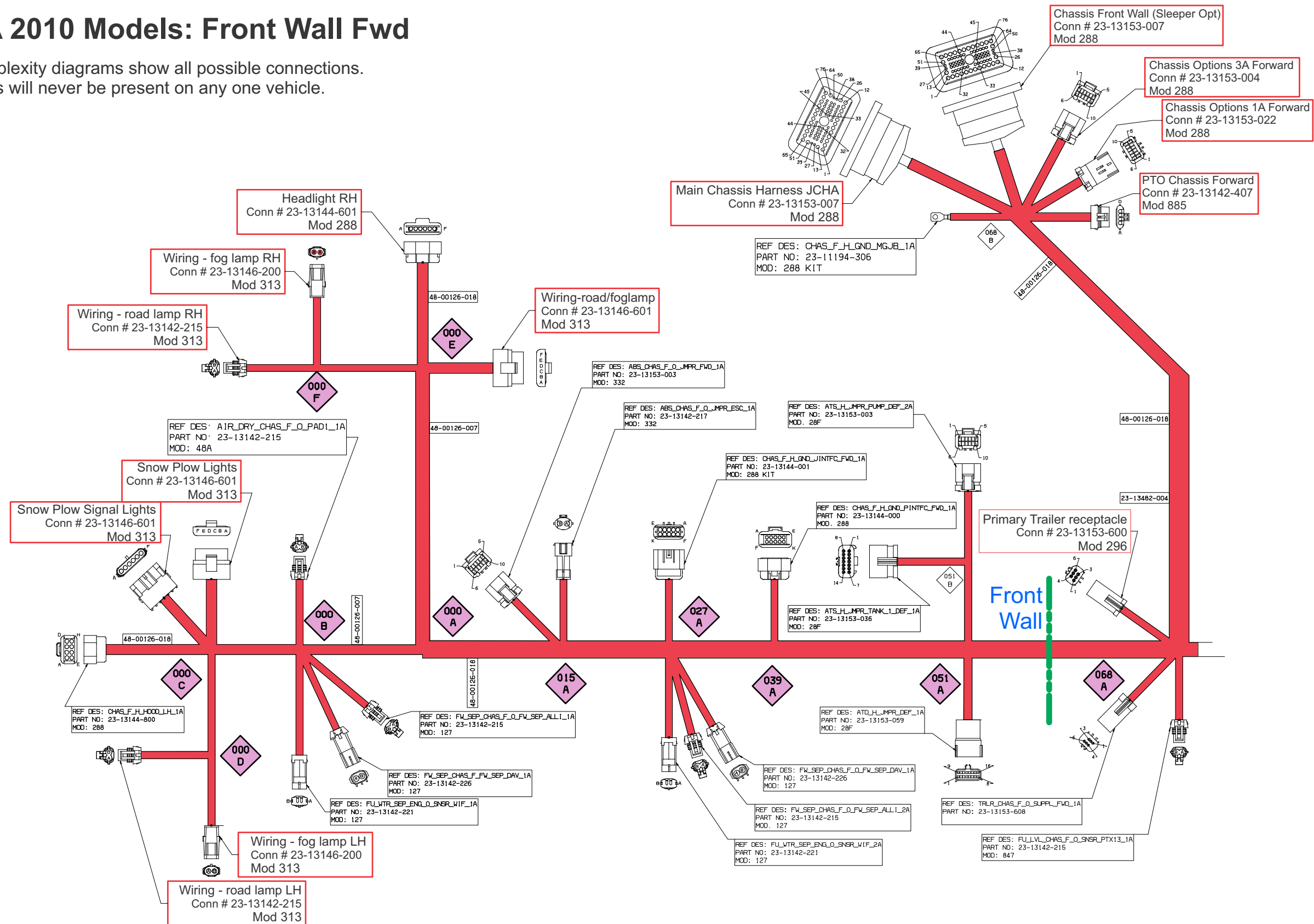





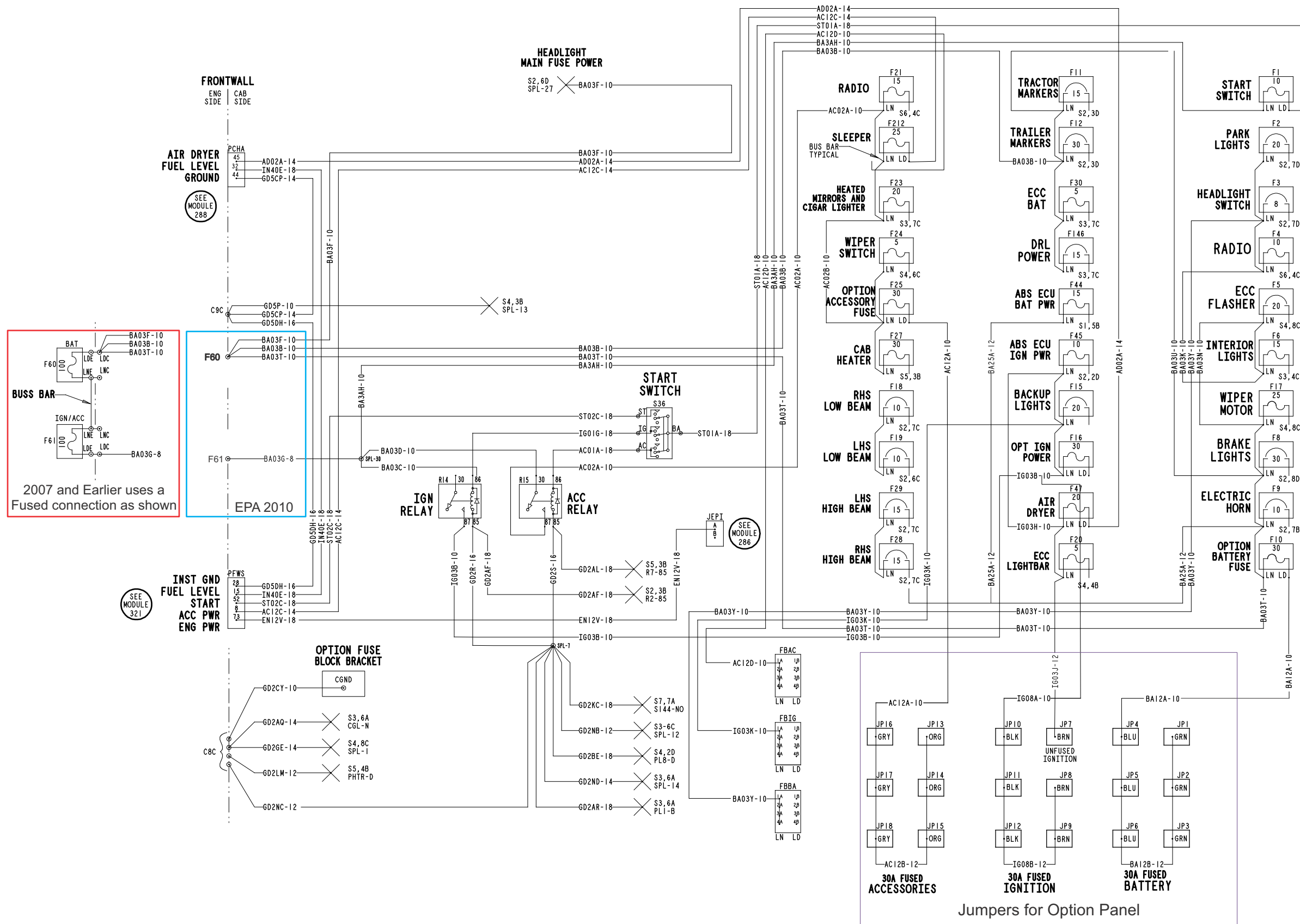



### 372-036 Dash mounted electrical PTO switch with indicator

Use with Allison Transmission in combination with DDC 13/15/16 Engines.

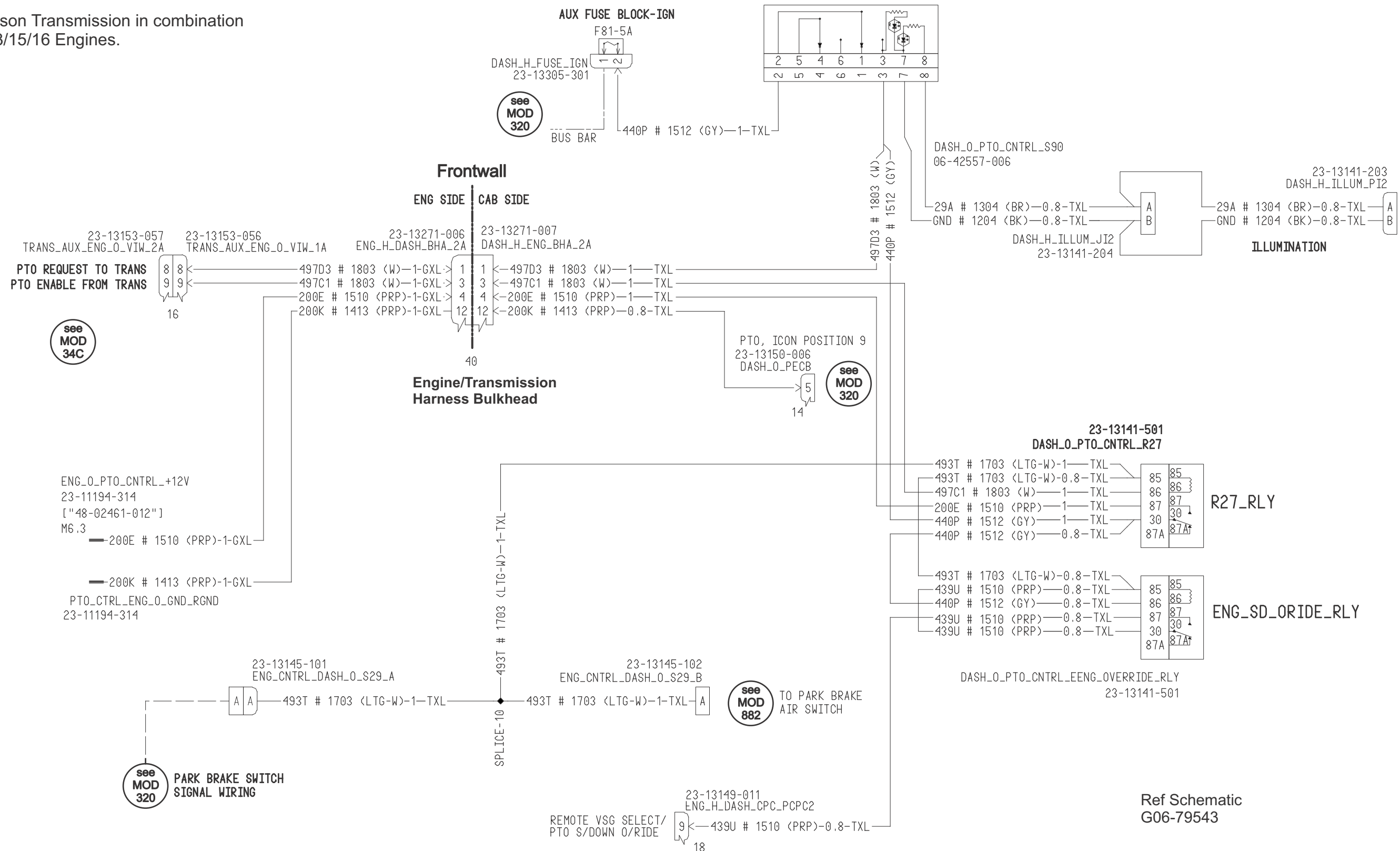

Ref Schematic G06-79543

### 372-033 Dash mounted PTO controls with indicator light and park brake interlock

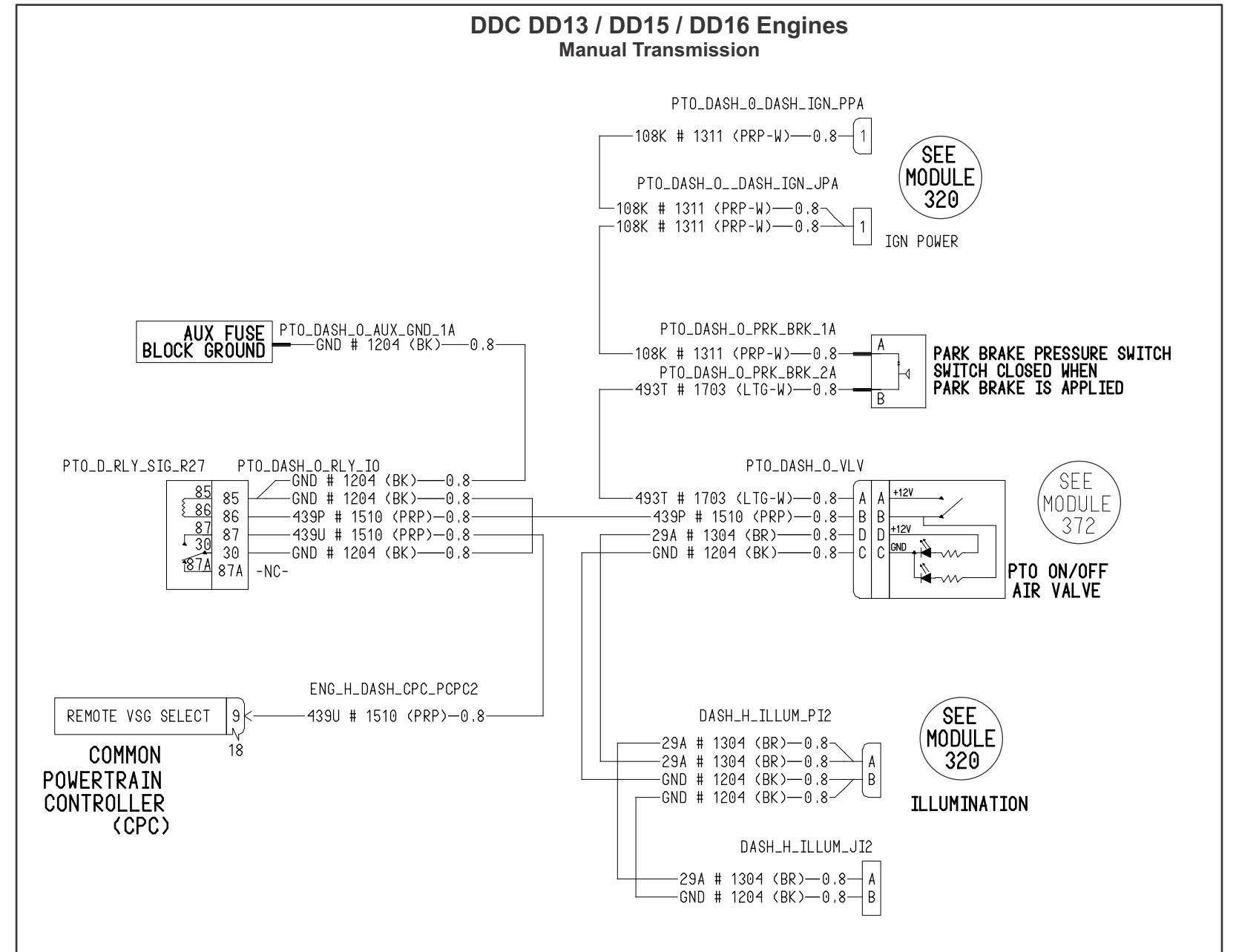
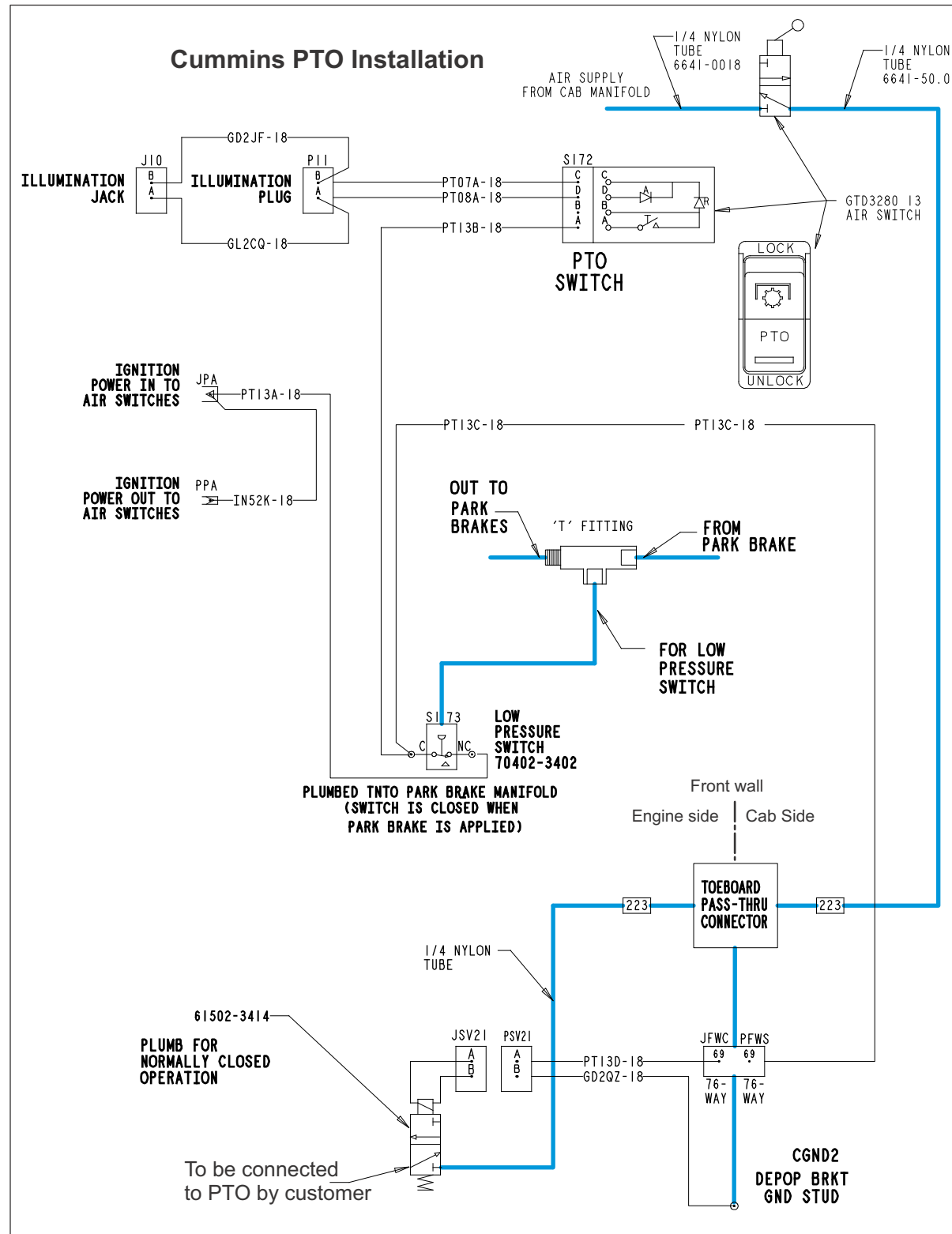

### Remote Fast Idle Circuits

- Wires 440D, 440F & 440E are spliced into the cruise switch wiring in the dash and run through the front wall at a 40 pin connector pins 11, 9 & 10 respectively.
- Harness P/N A06-74578-000 ties into the 40 pin connector on the engine side of the front wall and ends in a 6 pin connector with wires 440D, 440F, 440E & 440G. (This harness is approximately 51" long.)
- Harness WWS 87208-3428-210 connector PS19\_0 will connect to the 6 pin connector and have enough length to route to the end of frame, i.e. this harness is 210" long.

**148-070** Engine remote interface with preset fast idle

+

**163-008** Engine remote interface at back of cab with blunt cut wires

**163-009** Engine remote interface at End of Frame with blunt cut wires

**163-008** Engine remote interface at End of Frame with 6' extra cable

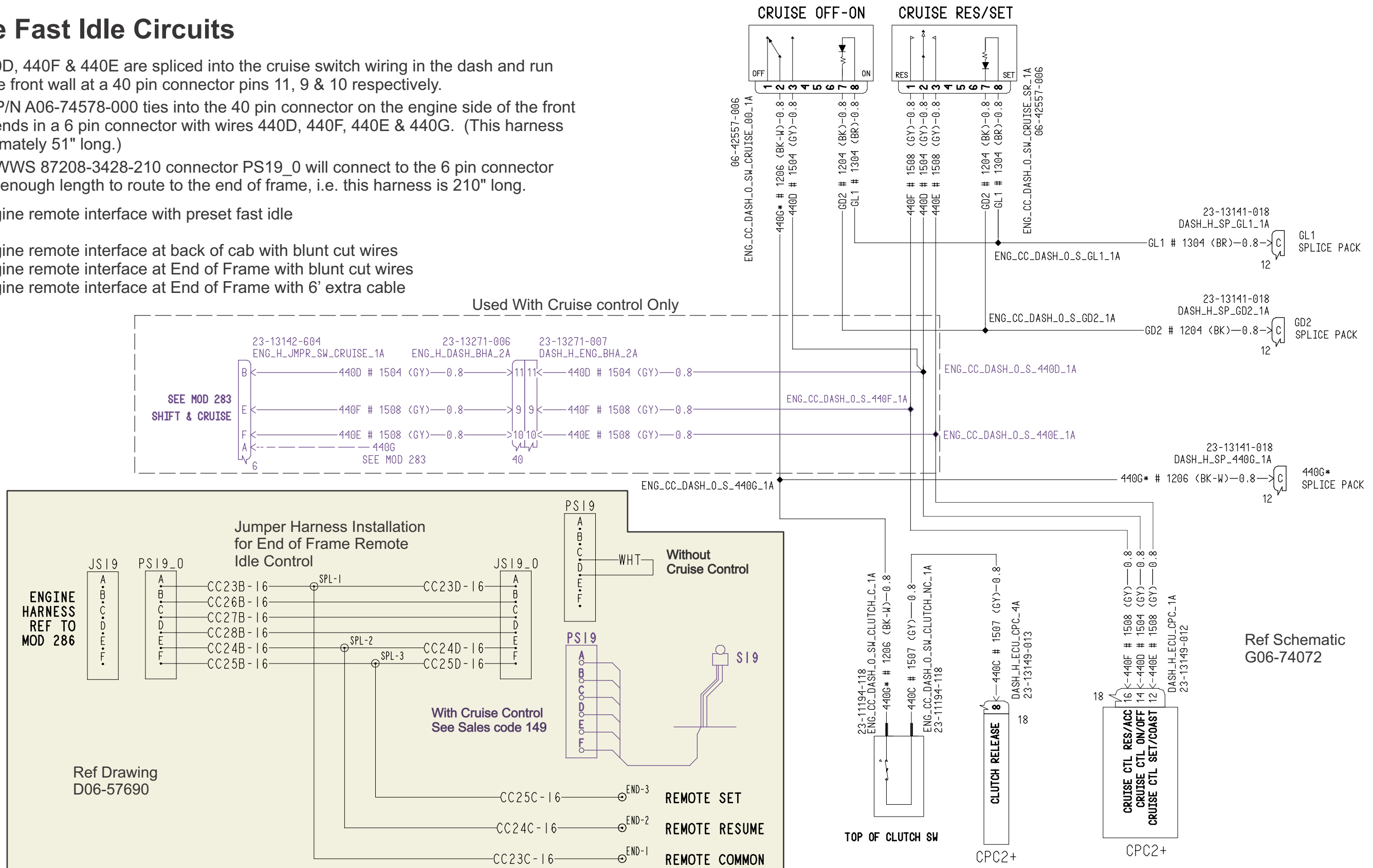



### 157-004 Manual remote engine start/stop

This solution supplies an internal cab harness that terminated at the Front Wall/Sleeper Harness Bulkhead connection plug see page 1-8 for pin more details.

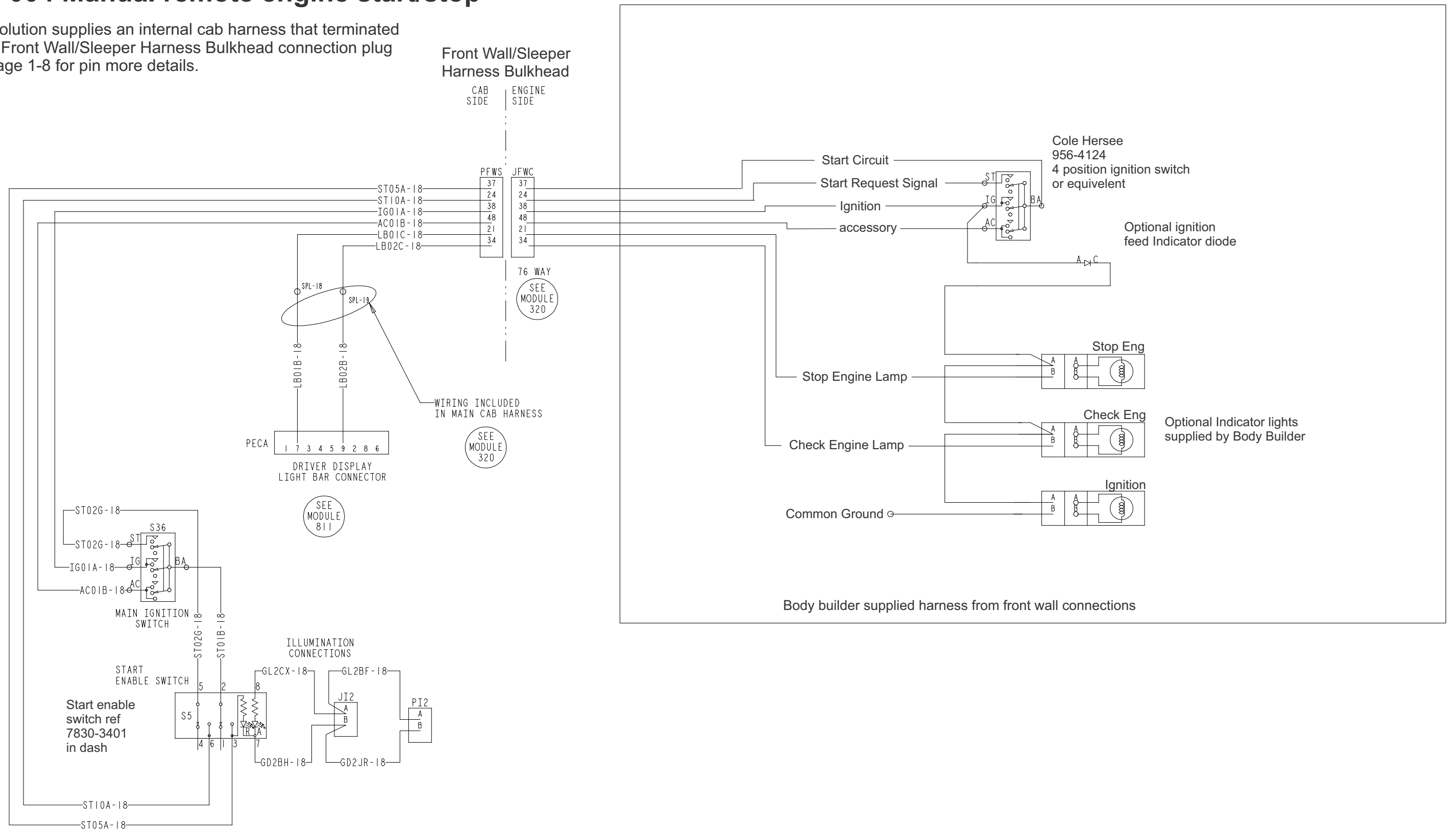



# 48/49/69 Engine Remote Interface - EOF

## End of Frame Engine Remote Interface - 148-035

**148-035** Preset fast idle switch interface for fixed single speed with engine compartment wires and park brake interlock

+

**163-998** No engine opt/rpm controls wiring

Dash Mounted 70 Pin engine connector PENG

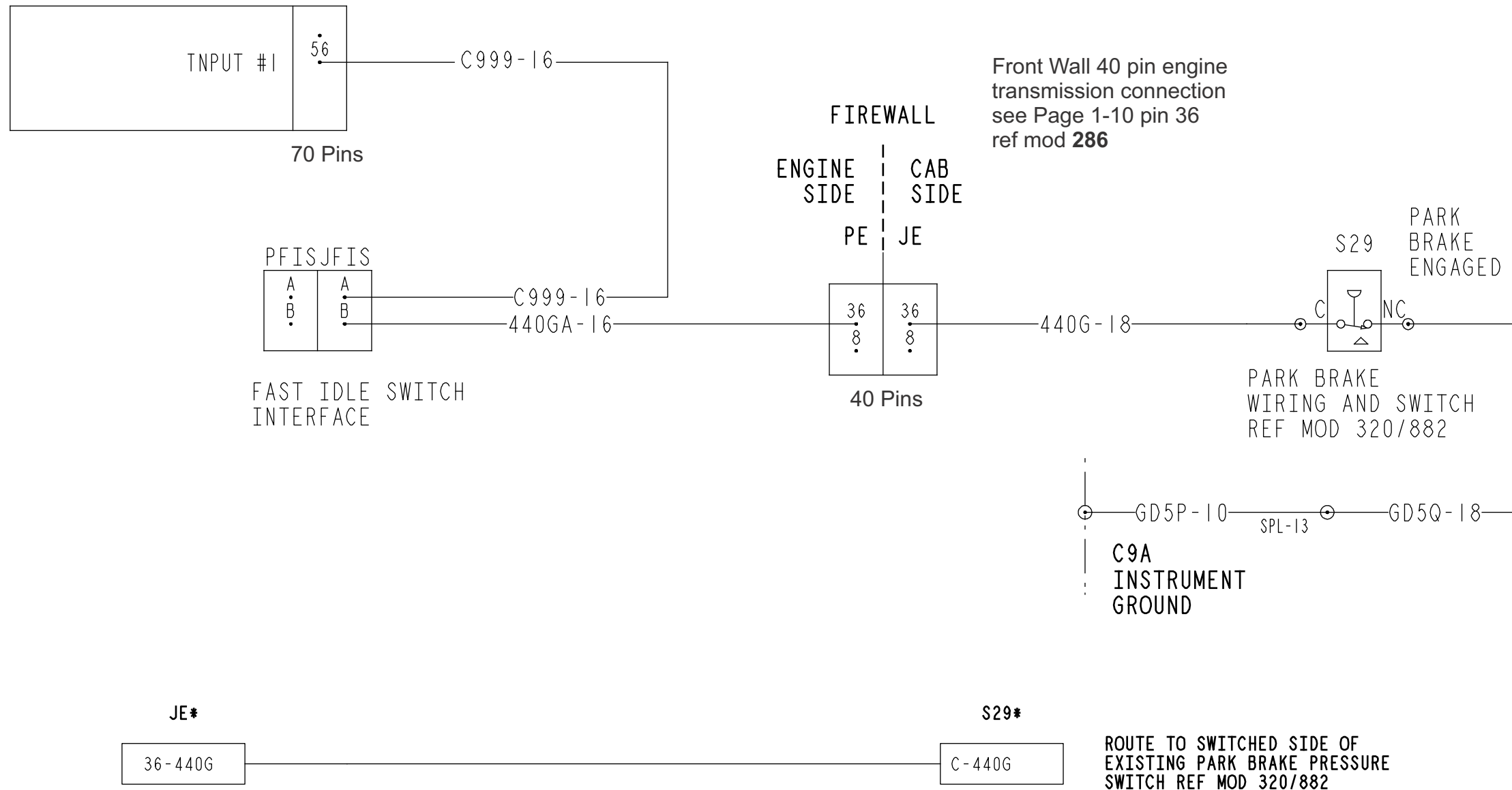





### 4800/4900/6900 Plow Light Prep

329-054 (5) Extra switches wired to 9 pole junction box mounted behind passenger seat

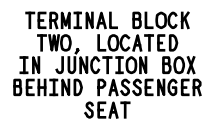
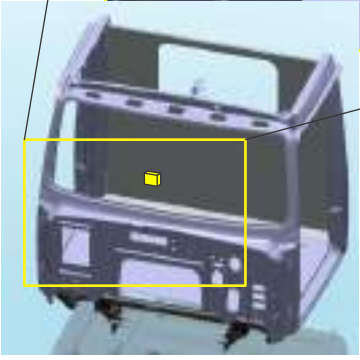
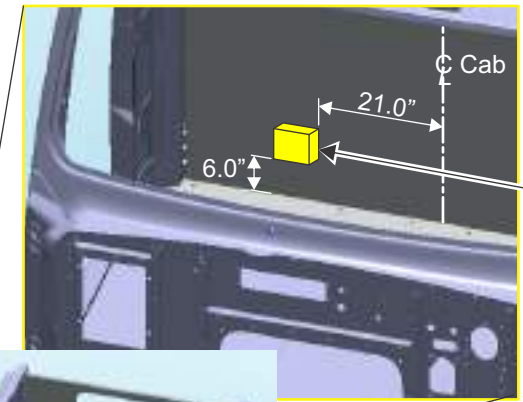
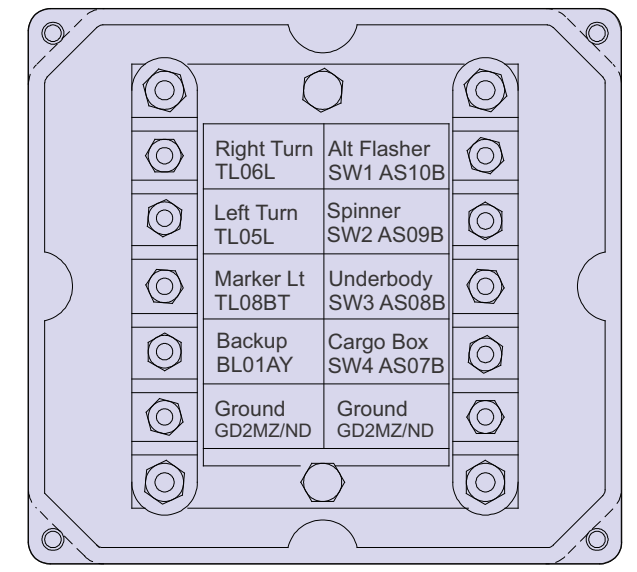
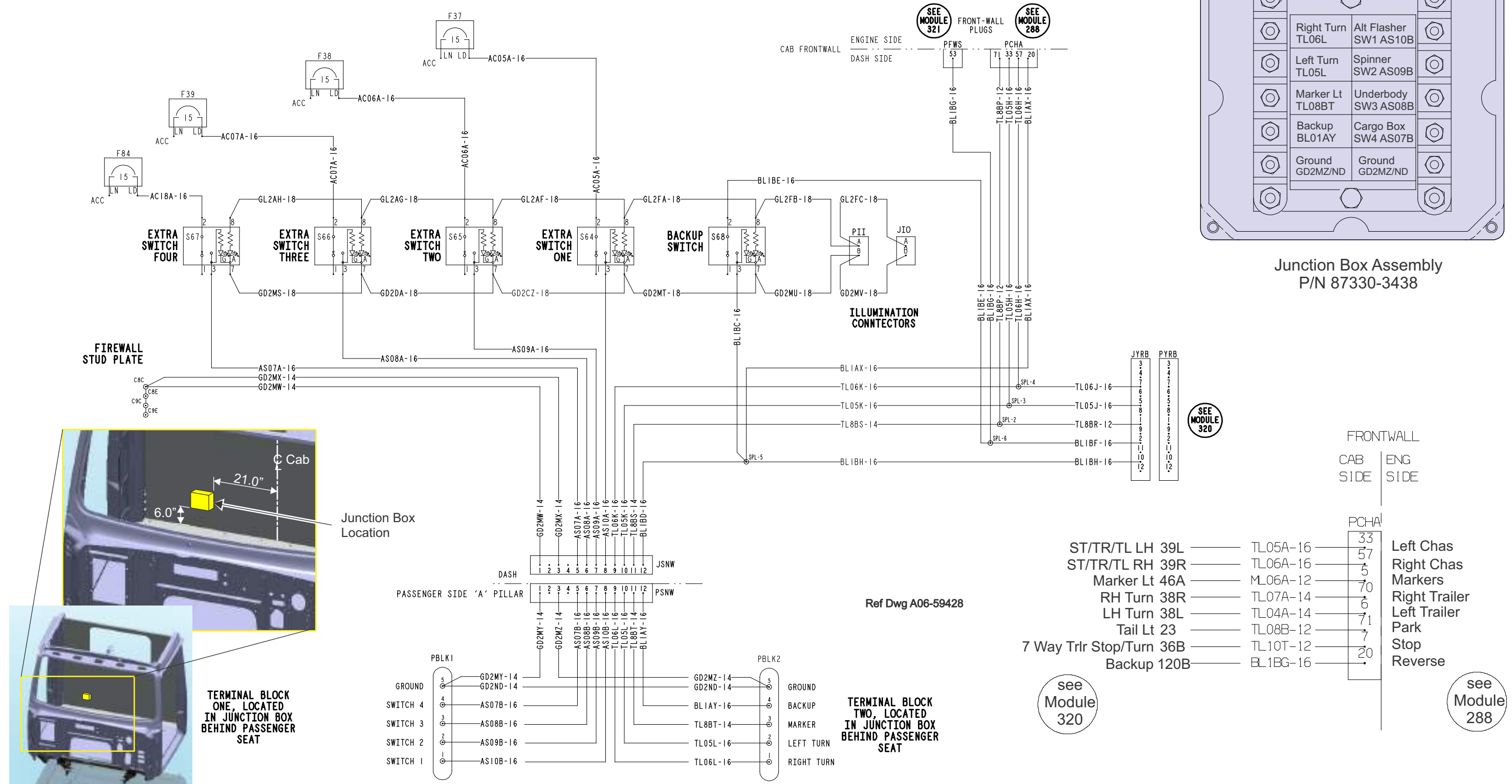

- |                          |          |    |               |
|--------------------------|----------|----|---------------|
| ST/TR/TL LH 39L          | TL05A-16 | 33 | Left Chas     |
| ST/TR/TL RH 39R          | TL06A-16 | 57 | Right Chas    |
| Marker Lt 46A            | M06A-12  | 5  | Markers       |
| RH Turn 38R              | TL07A-14 | 70 | Right Trailer |
| LH Turn 38L              | TL04A-14 | 6  | Left Trailer  |
| Tail Lt 23               | TL08B-12 | 71 | Park          |
| 7 Way Trlr Stop/Turn 36B | TL10T-12 | 7  | Stop          |
| Backup 120B              | BL1BG-16 | 20 | Reverse       |
- see Module 320
- see Module 288





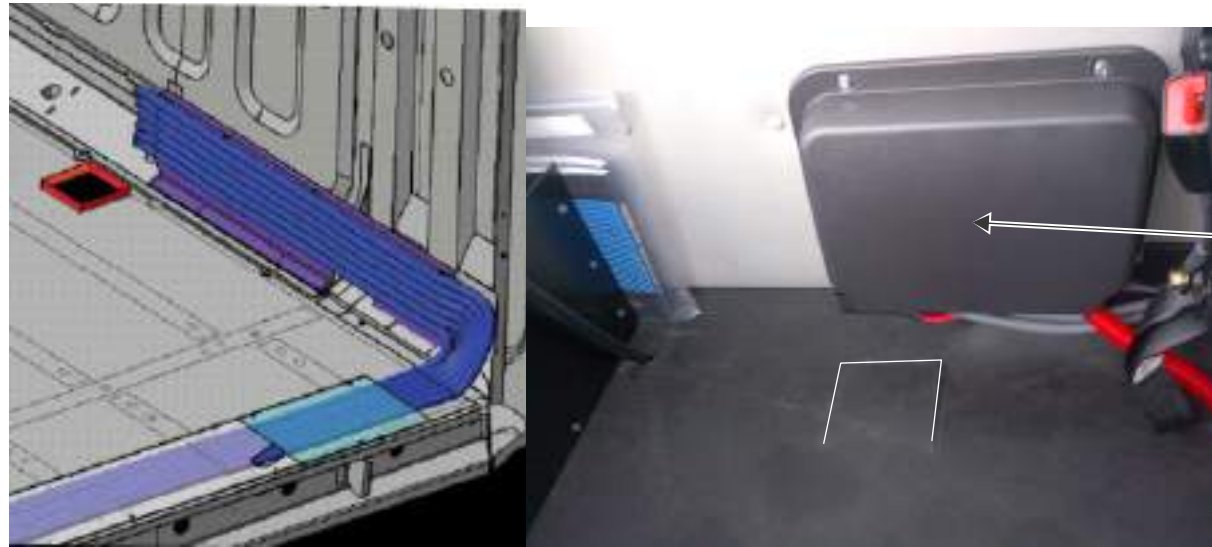

Accessing the cab on the 4700 SF and SB is quick and simple using the floor access plate at the back of the cab. look for cuts in the floor mat at the center of the cab under this flap is a cover plate which gives you structurally designed access from the chassis into the cab.

Plates can be removed from the unit and mounted at a workbench if desired for better sealing of cab mating harness.

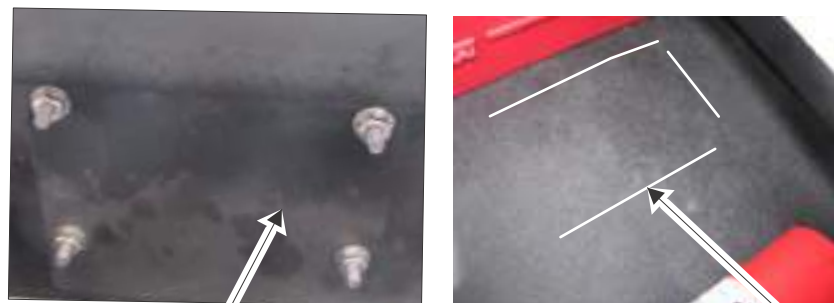

Easy Access Floor Plate

Cab Floor access

Pre cut floor mats

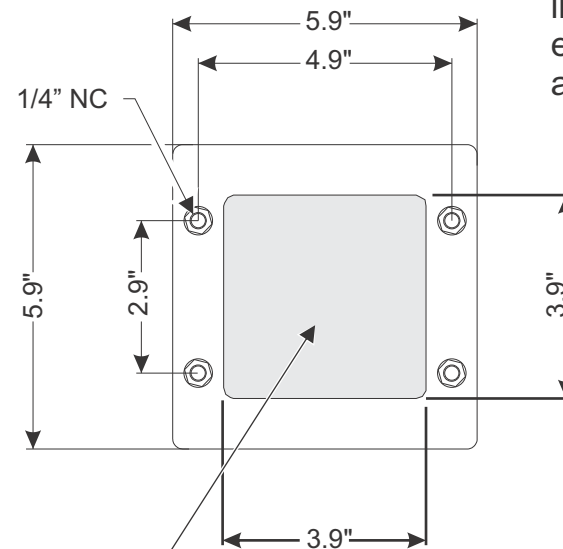

access opening in floor

Pre wired switch harnesses can be ordered using the option codes found in section 1A page 1A-1313

Switches can be blunt cut wires or prewired to an independant realy box ready for your body connections.

In cab connections are protected from the weather and corrosion.

Blunt cut switch wires coiled behind driver seat

Prewired switches are routed on a tray at the driver side floor board. this tray allows you to safely rout wires to the dash inside the cab and eliminates ephosteery and interior damage along with assembly time

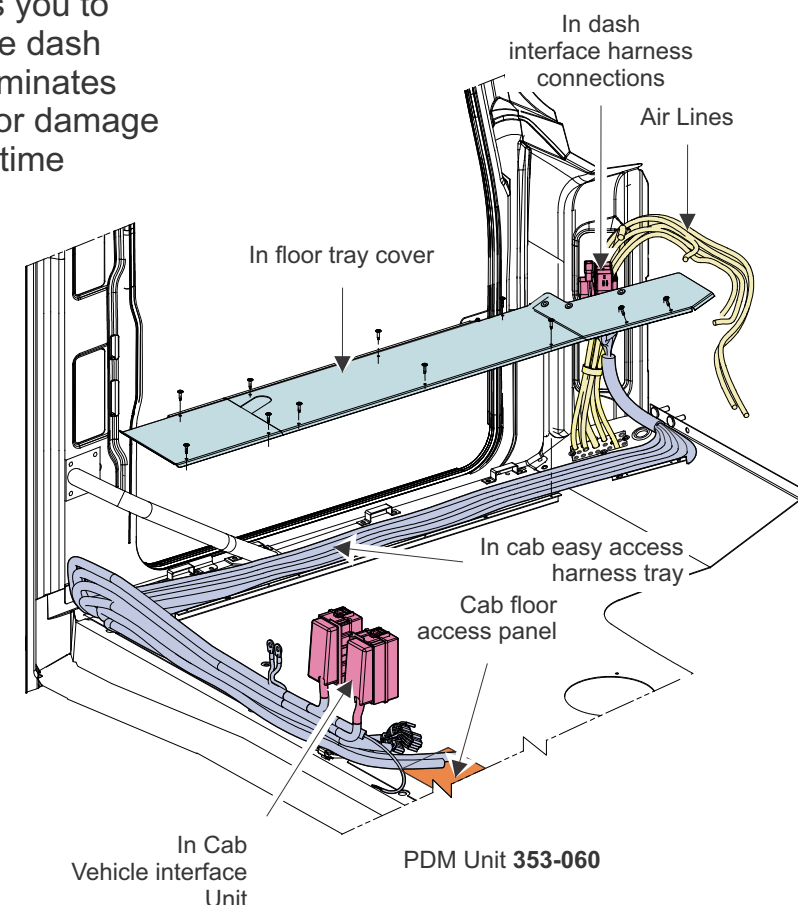
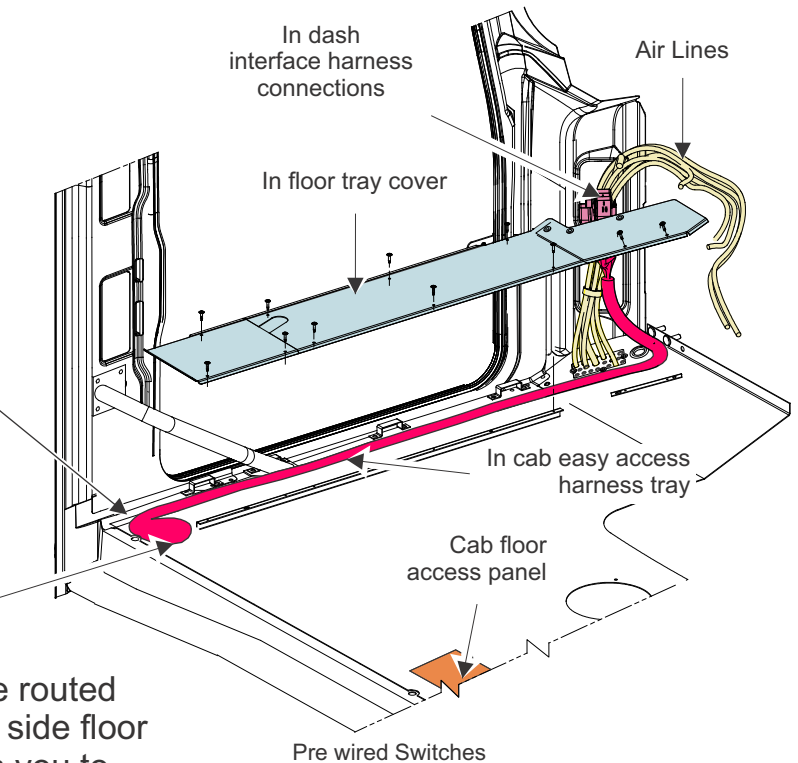

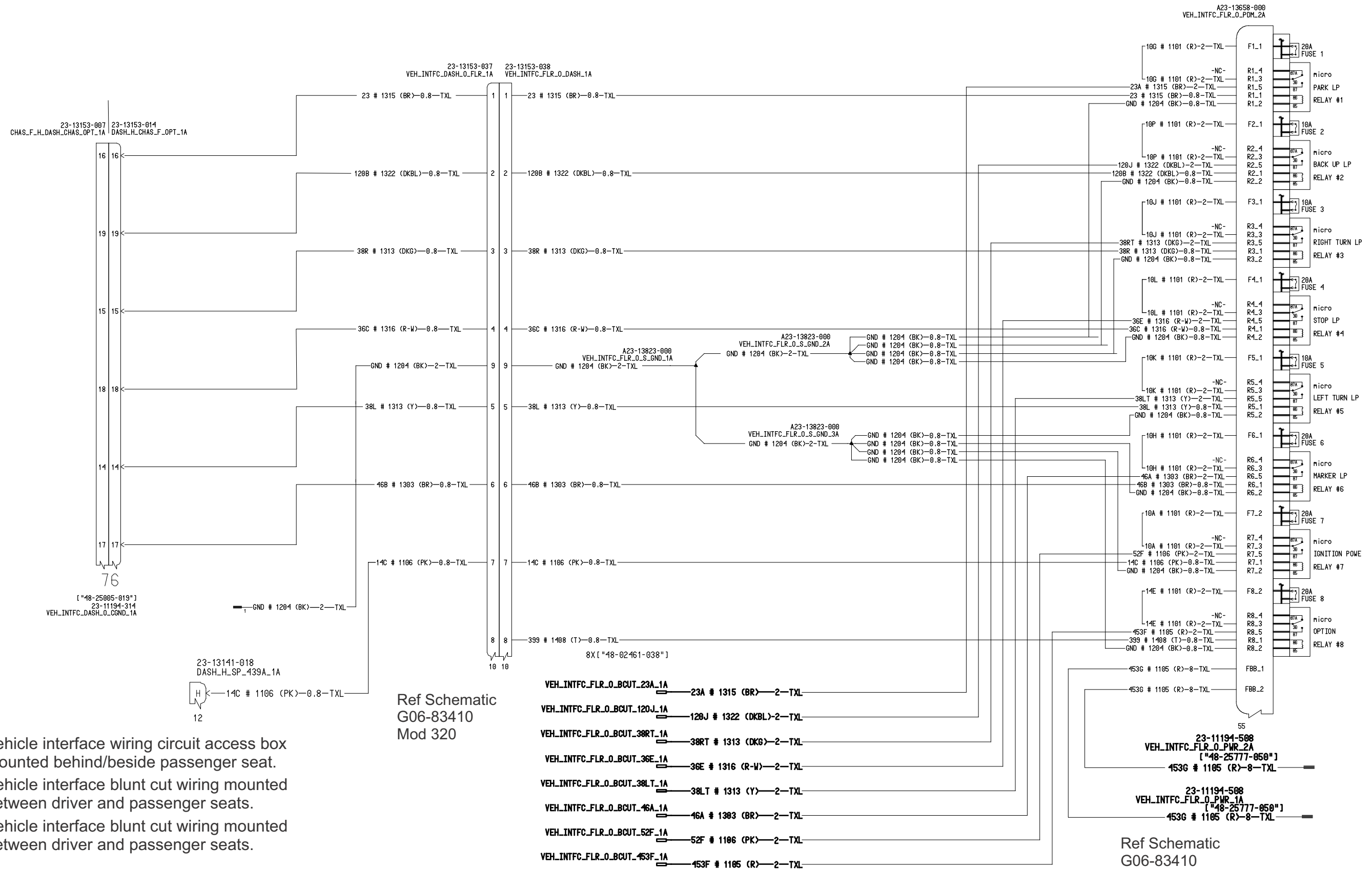

- 353-021** Vehicle interface wiring circuit access box mounted behind/beside passenger seat.
- 353-059** Vehicle interface blunt cut wiring mounted between driver and passenger seats.
- 353-060** Vehicle interface blunt cut wiring mounted between driver and passenger seats.

## Speed Sensor Connections Interface

Adding additional equipment such as the vehicle speed when installing a salt/sander spreader with a controlled flow rate at different speeds can be accomplished by adding a second.

adding a second speed sensor to the rear bearing cover of the transmission after delivery. You will need to purchase the following parts

P/N FUL K4148 (two wire speed sensor),  
P/N FUL X8 0801M (mounting screw)  
P/N A06-26585-000 (adapter harness)

to connect this signal to your system simply cut off the access end of the adapter harness and wire to body harness.

