

GUIDE FOR THE FITTING OF BODYWORK FOR THE RENAULT PREMIUM SERIES

50 21 001 985 - 06/01
édition anglaise



IMPORTANT

Reading the "Guide for the Fitting of Bodywork for the RENAULT PREMIUM series"

The "Guide for the Fitting of Bodywork for the RENAULT PREMIUM series" ushers in a new type of presentation for bodywork fitting guides.

This new presentation sets out in one single document all those details which are necessary for the bodybuilder and equipment manufacturer to have available.

The data given in the "Guide for the Fitting of Bodywork" ref. (DT 6/354) has been included in the present document under the "General Features" section at the beginning.

You therefore no longer have to refer separately to the "Guide for the Fitting of Bodywork" ref. (DT 6/354) in order to use and understand this document.

The present document consists of two sections:

- A - "General features": This describes the relevant general principles and basic rules applicable for the conversion and fitting of equipment to vehicles in most cases for the majority of applications.
- B - "RENAULT PREMIUM special bodybuilding features": This deals in greater detail with presentation of the vehicle, attachment of the body, electrical pre-arrangements, trade vehicles and trade packs.
- C - "Supplementary information on the RENAULT PREMIUM vehicle": This deals in greater detail with power take-offs, air-operated and specific equipment, assembly of equipment to chassis and cab.

If a topic is dealt with in the three sections, the relative information may be:

- **complementary**: in this case the "Special features" section provides details or values relating to the topic dealt with in "General features".
- **partially or fully contradictory**: when the RENAULT PREMIUM vehicle is endowed with a special feature whose characteristics go against general principles. In such case, the elements regarding this specificity in the "Special features" section supersede those dealing with the same topic in the "General features" section.

You may need, when looking for information on a specific point, to consult the three "General features", "Specific Features" and "Supplementary information on the RENAULT PREMIUM vehicle" sections, so as to ensure that you have obtained all the relevant details.

Carrossiers & Equipementiers
ATTENTION
véhicule électronique EURO3
Respecter IMPERATIVEMENT
les consignes de carrossage
ou
Contacter le constructeur

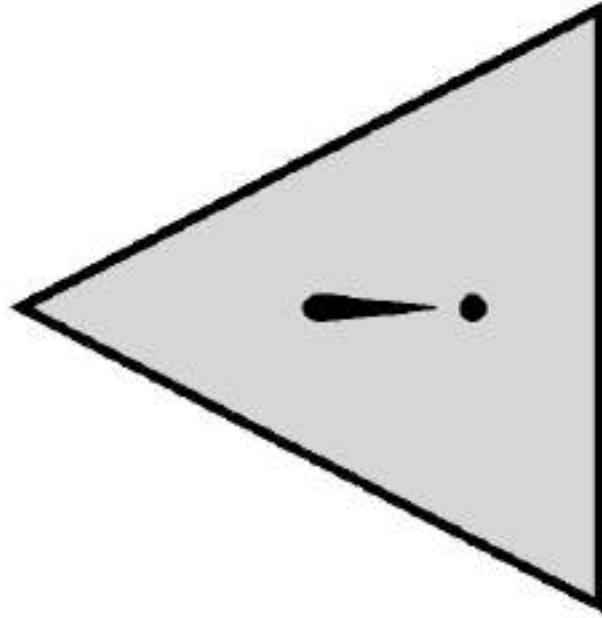

Karosseriebauer & Ausstatter
ACHTUNG
Fahrzeug mit Elektronik EURO 3
UNBEDINGT die Hinweise
für die Aufbauten beachten oder
sich an den Hersteller wenden.

Carroceros y proveedores de equipos
ATENCIÓN
Vehículo electrónico EURO 3
Respetar OBLIGATORIAMENTE
las instrucciones de carrozado
o
contactar con **RENAULT V.I**

Bodybuilders & Equipment Manufacturers
WARNING
EURO 3 electronically managed vehicle
It is **ESSENTIAL** to comply with
bodybuilding instructions
or
Contact the vehicle manufacturer

Carrozzeri e Allestitori
ATTENZIONE
Veicolo con elettronica EURO 3
Rispettare TASSATIVAMENTE
le istruzioni per la carrozzatura
o
Contattare il costruttore



RENAULT

CONTENTS

GENERAL RULES FOR CONVERSIONS

CHAPTER -A- GENERAL FEATURES

Page

1. GENERAL FEATURES	
1.1 Scope of liability	A2
1.2 Regulations	A2
1.3 Safety	A3
1.4 Quality assurance	A4
1.5 Documentation	A4
1.6 General instructions	A5
1.7 Safety on tilt cabs	A6
1.8 Chassis markings	A6
1.9 Adjustments to the vehicle settings	A7
1.10 Cleaning	A7
1.10.1 Bodywork	A7
1.10.2 Chassis/Underbodies	A7
1.10.3 Cleaning of the cab	A7
1.10.4 Cleaning of the instrument panel	A7
1.11 Safety and protection of components	A7
1.12 Summary of definitions	A8
1.13 Certificate of approval of the conversion of a vehicle	A9
1.13.1 Application for approval	A9
1.13.2 O Body fitting certificate	A9
1.13.3 Responsibility for installation	A9
1.14 Painting	A10
1.14.1 Precautions	A10
1.14.2 Major units	A10
1.14.3 Chassis frame and accessories	A11
1.14.4 Recommended products	A12
1.14.5 Marking of polymer components (recycling of plastics)	A13
1.15 Electrical equipment	A15
1.15.1 General	A15
1.15.2 Wiring Harnesses	A15
1.15.3 Electrical connections	A16
1.15.4 Available power supplies	A16
1.15.5 Flasher units	A16
1.15.6 List of standard power sockets	A17
1.15.7 Additional direction indicator lamps	A17
1.16 Air-operated equipment	A20
1.16.1 Regulations	A20
1.16.2 Polyamide pipes	A20
- Identification marking	A20
- Coding used on polyamide pipes (RENAULT V.I. Standard)	A20
- Brakes code	A20
- Coding used on pneumatic appliances (DIN Standard)	A21
- Replacement of a brake line	A21
- Modification to the length of the chassis	A21
- Connections for ratchet type pneumatic brake pipes type "RILAX 2000"	A21

2. GENERAL RULES TO BE OBSERVED WHEN FITTING BODYWORK	
2.1 General welding principles	A22
2.1.1 Precautions	A22
- Protection of the batteries	A22
- Soundproofing screens	A22
- Protection of electrical and mechanical components	A22
2.1.2 Preparation of parts for welding	A22
- Preparation of specific edges on chassis frames	A23
- Method of welding to be specifically used on chassis frames	A23
- Slave butts	A23
2.1.3 Welding process	A24
- Static or rotary arc welding set	A24
- Relevant standards	A24
- MIG or MAG semi-automatic welding set	A24
2.1.4 Equivalent steel grades	A25
2.2 Reinforcement, extension, reduction of sidemembers	A26
2.2.1 Bans	A26
2.2.2 Reinforcement of sidemembers	A26
- Examples of reinforcements	A26
- Method of joining	A27
- Extension, shortening of sidemembers in the wheelbase	A28
2.2.3 Modification of the rear overhang	A29
- Attachment of cross-members	A29
- Towing cross-members	A29
- Intermediate cross-members	A29
2.3 Attachment of bodywork	A30
2.3.1. Bans	A30
2.3.2 Protection against exhaust heat radiation	A30
2.4 Sub-frames	A31
2.4.1 Finishing of sub-frames behind the cab	A31
2.5 Nuts and bolts, tightening torque for parts in steel and cast iron	A32
2.6 Addition of equipment to the bodywork	A33
2.7 Rear run-under guard	A34
3. SPECIFIC EQUIPMENT FEATURES	
3.1 Running the engine when vehicle stationary	A34
3.2 Mounting of power take-offs and flanged pumps	A34
3.3 Front power take-offs (crankshaft nose) (except RENAULT PREMIUM / KERAX)	A35
3.4 Front and rear power take-offs	A35
3.4.1 Propeller shaft alignment	A35
- Angularity criteria	A35
- Angular acceleration criteria	A36
- Transversal stress criteria for prop shaft tubes and bearings	A36
3.4.2 Propeller shaft balancing	A37
3.4.3 Maximum permissible length of a prop shaft as a function of the rotating speed	A37
3.5 Vehicle driveline (powertrain)	A37
3.6 Mounting of handling cranes	A38
3.6.1 Mounting on the sub-frame	A38
3.6.2 Graph of the moment of inertia of the sub-frame as a function of the lifting torque	A39
3.6.3 Crane in the rear overhang	A40

3.7 Tail lifts	A41
3.7.1 Sub-frames	A41
3.7.2 Attachment	A41
3.7.3 Electrical connections for a tail lift	A41
3.7.4 Special recommendations for tail lifts from 1500 to 2000 kg without landing legs	A41
3.7.5 Graph of the moment of inertia of the sub-frame as a function of the lifting torque	A42
3.8 Sub-frame box sections	A43
3.9 Fitting of specific equipment	A43
3.9.1 Electrical connections	A43
3.9.2 Installation of receivers or generators with a voltage of more than 24 V	A43
3.10 Tapping on the diesel fuel tank	A43
3.11 Hitch coupling for drawbar rigid trailers (only on RENAULT MIDLUM)	A44
3.11.1 Fitting of an additional cross-member	A44
3.11.2 Minimum thickness of reinforcing plates	A44
3.12 Fifth wheels	A44
3.12.1 Mounting standards	A44
- Kingpin 50 mm (2") dia.	A44
- Kingpin 90 mm (3.5") dia	A44

CHAPTER -B- RENAULT PREMIUM SPECIAL BODYBUILDING FEATURES

1. PRESENTING THE "RENAULT PREMIUM" SERIES	B3
1.1 Changes to "RENAULT PREMIUM"	B3
1.2 Make-up of the series	B4
1.3 Electronic management of "RENAULT PREMIUM" vehicles	B6
1.3.1 Operating principle	B6
1.3.2 Bodybuilders' electrical pre-arrangements	B7
1.4 Warning	B7
2. GENERAL REMARKS ON THE "RENAULT PREMIUM" SERIES	B8
2.1 Identification of the vehicle	B8
2.2 General drilling principles	B10
2.2.1 Drilling cab panels for fitting accessories	B10
2.2.2 Drilling in sidemembers	B11
2.3 Precautions prior to welding	B12
2.3.1 Protection of wiring harnesses	B12
2.3.2 Welding on vehicles equipped with an electromagnetic master switch	B12
2.4 Minimum load on front axle	B13
2.5 Soundproofing screens and heat shields	B13
2.5.1 Instructions for soundproofing screens	B13
2.5.2 Instructions for heat shields	B13
2.6 Side impact beams	B13
3. INSTALLATION OF BODYWORK	B14
3.1 Use of 1/20th scale drawings and calculation sheets	B14
3.2 Example of a search	B14
3.3 Body entrance dimension	B17
3.3.1 Behind-cab surrounds	B17
3.3.2 Body entrances with vertical exhaust	B19
3.3.3 Presentation of the different air intakes	B20
3.4 Finishing of sub-frame entrance dimensions	B21

3.5 Sub-frame sections	.B23
3.5.1 Minimum height according to range of suspension movement	.B23
3.5.2 Sub-frame minimum inertia	.B23
3.5.3 Discontinuous sub-frames (2-part)	.B25
3.5.4 Continuous sub-frames	.B27
3.6 Attachment of bodywork	.B27
3.7 Attachment of sub-frames to brackets	.B28
3.7.1 Day cab guiding and fastening zone	.B28
3.7.2 Sleeper cab guiding and fastening zone	.B28
3.7.3 Vertical positioning of brackets	.B30
3.7.4 Transversal positioning of brackets	.B30
3.7.5 Types of bodywork attachment	.B32
3.8 Longitudinal positioning of brackets on chassis	.B36
4. ELECTRICAL PRE-ARRANGEMENTS	.B52
4.1 Available power supplies	.B52
4.2 Electrical pre-arrangements	.B52
4.3 Management of engine speed	.B57
4.3.1 Choice of engine speed by default	.B57
4.3.2 Use of the steering wheel fast idling control	.B58
4.3.3 Vehicle fitted with a power take-off	.B58
4.3.4 Use of the chassis-mounted fast idling control	.B59
4.3.5 Use of the chassis-mounted fast idling variable speed control	.B59
4.4 Electrical diagram for available power supplies	.B60
5. REFUSE COLLECTOR VEHICLE	.B66
5.1 Longitudinal positioning of brackets on chassis	.B66
5.2 Available power supplies at in cab on connection unit	.B68
5.3 Management of engine speed	.B69
5.4 Speed limitation	.B69
5.5 Electrical diagram for refuse collector vehicles available power supplies	.B70
6. HANDLING CRANES	.B74
6.1 Handling crane with lifting torque outside graph limits	.B74
6.2 Handling crane in rear overhang	.B74
6.3 Plate mounting recommendations	.B74
6.4 RENAULT PREMIUM behind-cab handling crane	.B75
7. TIPPERS	.B86
8. TANKERS	.B88

CHAPTER -C- SUPPLEMENTARY INFORMATION ON THE “RENAULT PREMIUM” VEHICLE

1. MOUNTING OF POWER TAKE-OFFS	C3
1.1 Mechanical receiver	C3
1.1.1 Gearbox-mounted PTO	C3
1.2 Instructions for the assembly of auxiliary hydraulic pumps to ZF type “C” PTOs	C6
1.2.1 Supplementary instructions	C6
1.2.2 Calculation of the weight torque	C6
1.3 Access to gearbox	C7
2. AIR-OPERATED EQUIPMENT	C8
2.1 Connection of extra auxiliary equipment	C8
2.1.1 Coupling for extra auxiliary equipment to chassis	C8
3. ELECTRICS	C11
3.1. Earths	C11
3.1.1 Cab earths	C11
3.1.2 Chassis earths	C12
3.2 Passage of wiring harnesses and compressed air pipes	C15
4. CHASSIS	C15
4.1 Steel classes for sidemembers	C15
4.2 Sections of sidemembers	C15
4.3 Reinforcement, extension, shortening of sidemembers in the rear overhang	C16
4.3.1 Modification to the rear overhang	C16
4.4 Intermediate cross-member	C17
5. CHANGING THE POSITION OF EQUIPMENT ON CHASSIS	C18
5.1 Rear run-under guard	C18
6. HITCH COUPLING FOR DRAWBAR RIGID TRAILERS	C19
6.1 Mounting principle	C20
6.2 Rear bevelling of sidemembers	C21
6.3 Attachment of towing hook to 40-44 tonne and 50-60 tonne cross-member	C22
7. ASSEMBLY OF EQUIPMENT TO CAB	C24
7.1 Roof catwalk	C24
7.1.1 Attachment of catwalk to day cab	C24
7.1.2 Attachment of catwalk to sleeper cab	C25
7.2 Ladder	C26
7.2.1 Attachment of ladder to day cab	C26
7.2.2 Attachment of ladder to sleeper cab	C27
7.3 Assembly of accessories on roof	C28
7.3.1 Installation of antennae	C28
7.3.2 Installation of revolving beacons	C28
7.3.3 Installation of air horns	C29
7.3.4 Installation of roof deflector	C30
7.3.5 Installation of frontview mirror	C31
7.3.6 Installation of sunshade	C32
7.3.7 Installation of gantry	C33
7.4 Fastening of accessories	C34
8. AIRBAG	C35
8.1 Identification of a vehicle equipped with an airbag system	C35
8.2 Work on the vehicle (excluding the airbag) requiring precautions to be taken to avoid inadvertent deployment of the airbag	C35

CHAPTER -A- GENERAL FEATURES

1. GENERAL FEATURES

1.1 Scope of liability

RENAULT V.I. vehicles are merchandized at the end of corroborated technical designwork and endurance testing, taking the various laws, regulations, standards... involved into consideration.

Modifications to a RENAULT V.I. vehicle for the fitting of bodywork and equipment should be carried out in accordance with the rules and recommendations set out in this bodywork fitting guide and require an "Agreement in Principle", issued by the Product Applications Department.

Guarantee and responsibility

Any intervening party is responsible for his services in terms of guarantee and responsibility, including any damage caused by his work and/or the equipment installed on-vehicle or the basic product.

In the event of RENAULT V.I. (or its network) being prime contractor for its own equipment (in relation to the end customer), the guarantee is considered as being at least that of the warranty offered by RENAULT V.I. to its customer.

Unless clearly specified otherwise in the order, the equipment warranty shall be negotiated directly between the end customer and the equipment manufacturer.

The meeting of recommendations contained in the present document can in no way be considered as relieving the equipment manufacturer's responsibility, but simply as complying with the basic rules for professional trade practice.

Any breach of these recommendations must be considered as shortcoming in respect of the rules and shall relieve RENAULT V.I. of its liability in the event of damage connected directly or indirectly to such non-compliance.

All the equipment is considered to comply with these recommendations and shall not require any acceptance testing upon delivery to check the conformity.

RENAULT V.I. guarantees non-modified original parts and components.

Interventions, conversions, adaptations of fittings carried out by the intervening party involves his responsibility, even if they are authorized administratively (Conversion appendix II).

Such conversions must not under any circumstance lead to any impairment of the quality or of the primary functions of the component elements of the vehicle (whether these elements are affected directly or not by the intervention).

Any modification, changing of position of constituent vehicle parts or elements must be covered by an "Agreement in Principle", issued by the RENAULT V.I. Product Applications Department.

For further information or assembly agreement, contact:

TO OBTAIN ANY INFORMATION OR APPROVAL OF MOUNTING, PLEASE CONTACT:

For France:

SERVICE TECHNICO-COMMERCIAL

RENAULT V.I.

API. COM 00A 238

69806 ST PRIEST CEDEX

Tel.: 04 72 96 68 14

Telex: 300 265 UDCF +

Fax: 04 72 96 81 93

For the United Kingdom:

Product Applications Department

RENAULT V.I. UNITED KINGDOM LIMITED

Boscombe Road,

Dunstable

Bedfordshire LU5 4LX

Tel. (Switchboard): (+44) (0)1582 471 122

Fax (Marketing) (+44) (0)1582 479 146

1.2 Regulations

The bodybuilder must meet:

- the different European and/or destination country laws, regulations and standards governing driving and vehicle building,
- the stipulations of the highway code and its various amendments and appendices,
- the different laws, regulations and standards governing road traffic in force in the country of destination.

The scope of this compliance must cover:

- Lighting and signalling,
- Weight and dimensions,
- The field of vision and rear view,
- The regulation protection devices (e.g. side beams, anti-spray, run-under guard),
- The hitch coupling and towing systems, (compliance with standards and regulations),
- Specific clauses concerning the transport of dangerous goods (ADR, COSHH etc.),
- Sun-roofs,
- Pollution control standards,
- Electromagnetic compatibility standards for electronic equipment.

1.3 Safety

All components having an influence on:

- The control of the driver of the trajectory and the ability to stop the vehicle and its trailer,
- The load distribution on the front or the rear, the left or the right,
- The risk of fire,
- and any other risk for the vehicle and its surrounding environment.

Among the components, we would mention, among others:

- The cab tilt mechanism,
- The wheels (tightening of the bolts),
- Seats and seat belts (anchorage points),
- The attachment of bodywork or equipment to be in conformity with the technical instruction document in force, (i.e. the Guide for the Fitting of Bodywork),
- The hitch coupling and towing systems, (i.e. anchorages),
- Electrical systems (protection of circuitry, the electrical rating, attachment, conformity of the connections with the technical instruction document, (i.e. the Guide for the Fitting of Bodywork),
- Warning systems and driver information systems, (i.e. no interference with the information given by the instrument panel on the dashboard),
- Information for use affixed by the manufacturer to the vehicle (i.e. decals for tilting of the cab, drilling points, welding points, batteries, etc.)
- Extension and reduction of the length of the wheelbase and the rear overhang.
- Re-location or replacement of the crossmembers.
- Circuits for ancillary equipment.

In order to guarantee the safety and the satisfactory operation of the vehicle, modification of the following components is strictly forbidden:

- Brakes: circuits, controls and anchorages,
- Steering: circuits, controls, anchorages and geometry,
- Axle and axle housing assemblies,
- The air-bag system and pretensioning systems on the seat belts,
- The electronics.

1.4 Quality assurance

Our permanent objective is to give satisfaction to our customers and we must achieve this in full on the final product consisting of a chassis, bodywork and/or an item of equipment.

In order to achieve this objective, RENAULT V.I. expects from all those co-operating with it in the field of mounting bodywork and equipment supply to implement a Quality Assurance System.

RENAULT V.I. can demand proof for the execution of all bodywork, the fitting of equipment or modification of a basic truck, in accordance with Standard ISO 9000, of:

- The conformity with all legislation, EC Directives and national regulations,
- The compliance with the manufacturers' directions,
- The control of quality of the execution of the work.

This is done with the knowledge that, on the face of it, the vehicle is considered as complying with the whole of the regulations.

1.5 Documentation

In all cases involving equipment, the installer is obliged to supply a manual covering the use, service, maintenance and safety of his installation.

1.6 General instructions

When building and fitting a body (including such equipment as rear run-under guards), a certain number of requirements and a certain number of vital requirements specific to each type of vehicle must be taken into consideration. These various points relate to maintenance, accessibility and the circulation of fluids.

Examples:

- Ease of access to the various maintenance and lubrication points, to the fuel tank and fuel gauge, to the batteries and the various electrical terminal boxes.
- The ability to easily dismantle the various component parts of the transmission and the suspension.
- Access to the circuits for air-intake, exhaust, and fuel supply.
- Taking into account the wheel movement detailed on the bodywork drawing (i.e. take care to allow for snow chains; extra clearance must be provided).
- Ventilation of the brake drums and discs and the battery compartment.
- The radiator inlet and outlet areas, which must not be modified.
- Complete compliance with the dimensions and weights specified in our technical documents. Under all circumstances, the bodybuilder must ensure free movement and safe operation of all the moving component parts of the chassis (i.e. springs, prop shaft, etc.)
- The addition of a body must not affect the vehicle running and driving safety. Take care to ensure that a balanced distribution of the loads on the right and the left hand sides of the vehicle is obtained.
- For any bodywork installation, a calculation of load distribution must be made for each axle, in order to check that the weight imbalance between the right and the left hand side is below 4%.
- The flow of the coolant must be maintained at all times. It is, therefore, not allowed to blank off, even partially, the air intakes provided (on the radiator grille or the front end). Orange ADR or similar "Hazardous Substances" plates should be affixed to solid surfaces (i.e. without vent holes).

On the arrival of a vehicle in your workshop for body fitting, we recommend that you should check one hour after the arrival of the vehicle, the state of charge of the batteries.

Voltage at the battery terminals		Specific gravity of the electrolyte	State of charge
6 Volt battery	12 Volt battery		
6.3 Volts	12.7 Volts	1.27	100 %
6.2 Volts	12.5 Volts	1.24	80 %

During the period for the fitting of the bodywork, you should particularly check that:

- The vehicle is not run without a battery.
- Do not move the vehicle on the starter motor.
- Do not use a booster starter.
- Ensure that the tyre pressure is checked and tyres inflated to the correct value where necessary.
- Protect body components or items of trim against all damage.
- Refit the original batteries, where these have been taken off.

IMPORTANT

- Whatever work you are doing on the vehicle, you must switch off the electrical circuit at the master switch or by disconnecting the batteries in order to avoid any risk of electric shock during work.
- When a vehicle is laid up (i.e. at a standstill for longer than 10 days), disconnect the electrical circuit by removing the fuse or by the circuit-breaker so as to avoid discharge of the batteries through the tachograph.

The information contained in this manual is only applicable to bodywork in steel. For aluminium bodies, refer to the Product Applications Department of RENAULT V.I.

It is forbidden to weld, grind, cut up, drill or heat the sidemembers or crossmembers unless the contrary is clearly stated. These operations may only be carried out in conformity with the recommendations laid down in the present document.

Any special case, any bodywork fasteners and fittings not described in this manual must be submitted for our approval prior to use.

Before commencing the fitting of any bodywork, you must consult:

- The Vehicle Technical Data Sheet,
- The bodybuilders drawing and the relevant calculation sheets which relate to the body to be fitted,
- The vehicle driving and maintenance handbook.

If you do not have these items available, you should obtain them from RENAULT V.I. Dealers or the Product Applications Department.

In the technical manual and on the bodywork drawing is stated the permitted maximum and minimum length of body; we would strongly advise you to stay within these limits.

Furthermore, it should be noted that the changing of position of a component such as spare wheel, tank, etc., the modification of a chassis without uniform weight distribution or the fitting of an over-cab extension, causes a modification of the load distribution of a fully equipped chassis in every single case.

Modification to load distribution must be compensated for by an alteration in the permitted length for bodywork. It then becomes necessary to calculate the new position of the centre of gravity of the bodywork.

The weights specified in our technical data sheets refer to standard vehicles, ready for the road, without optional extras.

Furthermore, the weight of chassis cab is given with a tolerance of plus or minus 4%.

Optional equipment such as reinforced springs, power take-offs, different tyre fitments, will cause an increase in weight for the basic chassis.

For these reasons, when weighing the chassis cab, bodybuilders should weigh:

- The front axle(s),
- The rear axle(s),
- The complete vehicle,

without driver, without passenger, but with full fuel tanks and with vehicle on-board tool kit.

For the preparation and attachment of the various types of bodywork, it is preferable not to take off the wheels, unless absolutely necessary.

Nevertheless, you must take the precautions set out below:

- It is forbidden to paint the bearing surfaces of the wheel rim hubs and the seating for wheel nuts.
- During fitting, make certain that the parts are perfectly clean prior to fitting.
- Tighten the wheel nuts to the torque recommended (cf. vehicle driving and maintenance handbook)

Installation fitted with keys: the section of such keys must be very different to that used for the vehicle keys. Indeed, these keys should not be able to be put into the vehicle locks by mistake, thus avoiding any risk of damage to the barrels of the locks.

1.7 Safety on tilt cabs

After the conversion of standard cabs by the bodybuilders, (i.e. extension, bunk adaptation, over-cab extension, etc.) because the weight distribution has changed, the tilt system may no longer meet the requirements of the safety standards.

Under these circumstances, and without prior agreement from the manufacturer, the full and entire responsibility rests with the bodybuilder.

1.8 Chassis markings

The identification number of the vehicle is on the sidemember (refer to the vehicle driving handbook).

The identity markings of the vehicle must remain visible and accessible without having to remove any part of the body.

1.9 Adjustments to the vehicle settings

Under no circumstance may bodybuilder or converters make any alteration to the original settings of RENAULT V.I. vehicles.

1.10 Cleaning

1.10.1 Bodywork

So as not to cause any damage to the condition of the paintwork and the seals:

- Avoid using a high temperature jet of steam.
- Restrict the use of brushes. They must be in good condition and well maintained.
- We advise against the use of brushes, during the first month of vehicle use.
- If you are using a high pressure jet wash unit, limit the pressure to 80 bars maximum.
- Keep the lance well away from the bodywork; do not spray fluidtight joints.
- Use neutral soap based products.
- In order to remove grease spots, use cleaning fluid (not petrol).
- Parts in aluminium must be cleaned with water to which a non-alkaline washing product has been added, and rinsed with clean water.
- Spread a coat of Vaseline or talcum powder over the seals.

1.10.2 Chassis/Underbodies

Use a high pressure unit. Limit the pressure of the jet to 80 bars maximum and the time of use to the strict minimum necessary.

In order to prevent any risk of a problem, do not spray:

- electronic or electrical boxes,
- the seals of link rods,
- hinge pins,
- air inlets for the heater, the engine air intake and air filter,
- pneumatic and electrical apparatus,
- absorbent materials and soundproofing screens,
- the fuel gauge.

1.10.3 Cleaning of the cab

Spray lightly or use a cloth dipped in a cleaning agent (i.e. soapy water, methylated spirits, etc.). Products with a petroleum and trichlorethylene base are not to be used.

Spread talcum powder lightly onto the door seals and the windows, as well as any link rods.

1.10.4 Cleaning of the instrument panel

Only use soapy water. Any other product is not allowed.

1.11 Safety and protection of components

Before any operation of grinding, drilling, or welding, ensure that the following are effectively protected or taken off:

- Plastic pipework and tubes,
- Electrical wiring harnesses,
- Suspension springs (particularly for the protection against corrosion),
- The bags for the air suspension,
- The soundproofing screens,
- Any other component sensitive to heat, to the discharge of incandescent matter, to ultraviolet rays (i.e. electronic control units, electronic components, items in plastic material, flexible anti-vibration mountings, painted items, etc.)
- For welding work, comply with the other recommendations described in the chapter entitled "Protection of electrical and mechanical components".

1.12 Summary of definitions

Maximum body length (Dimension W on technical data sheets and bodywork drawings).

This is the bracket of lengths for bodies (not including fittings and accessories) worked out in relation to the extreme positions of a given centre of gravity for a load which is taken to be evenly distributed and taking into account the space which must be left to the aft of the cab, laid down by the manufacturer, and the maximum permitted loads per axle on a chassis cab without options.

Body entrance (Dimension B on technical data sheets)

Minimum distance between the front axle centre-line and the front end plane of the body.

Load distribution calculations

Comply with the regulatory constraints for each country and the load limits given per axle for each model by RENAULT V.I.

We remind you that these values are given for uniformly distributed loads.

The lateral imbalance of the loads should not exceed a maximum of 4% between the LH and RH roadwheel of each axle.

Chassis rear overhang (Dimension N on technical data sheets)

Horizontal distance between the centre-line of the rear roadwheels and the rear extremity of the body (excluding fittings and accessories).

In the case of vehicles with 3 or 4 axles: distance between the centre-line of the rearmost axle and the extremity of the chassis.

Body rear overhang (Dimension X on technical data sheets)

Horizontal distance between the centre-line of the rear roadwheels and the rear extremity of the body (excluding fittings and accessories).

In the case of vehicles with 3 or 4 axles: distance between the technical centre-line of the tandem and the rear extremity of the body.

Wheelbase (Dimension F or F' on technical data sheets).

Distance between the centre-lines of the front and rear roadwheels (vehicle laden).

In the case of vehicles with 3 or 4 axles: distance between the centre-line of the front roadwheels and the centre-line of the foremost rear axle - for calculations take dimension F' (technical wheelbase).

Tandem

Solely in the case of vehicles with 3 or 4 axles: the 2 rear axles taken together, regardless of whether they are driving axles or trailing axles.

Maximum axle weight

Carrying weights are stipulated on each axle for each type of vehicle. These values are indicated on the technical data sheets and on the VIN plate and must be complied with on all vehicles fitted with bodies when laden and when empty.

Driver and cab passengers weight

The weight of the driver and passenger (passengers) in the cab is applied to the front axle in the case of a forward control cab.

For cabs of the semi-forward control type, 2/3 of the weight should be applied to the front axle and 1/3 to the rear axle.

Weight of driver or each passenger: 75 kg (calculated on the basis of the cab seating capacity), unless stipulated otherwise: i.e. Export, Army, Fire Brigade, etc.

For cabs with a seating capacity of more than 3 persons, calculate the weight distribution of the persons on the basis of the seats layout.

For equipment intended for the Army or for Civil Administrations, take the specific specifications into account.

1.13 Certificate of approval of the conversion of a vehicle

1.13.1 Application for approval

- 1** If the body or the equipment fitted do not modify the weight and dimensional characteristics of the chassis entered in the descriptive sheet, the vehicle can be submitted to the Type Approval Department without any action by RENAULT V.I. being necessary (within the permitted limits in force).
- 2** The maximum rear overhang is equal to 60% of the wheelbase. However, for special cases, we can grant higher percentages - for this, consult us.
- 3** If the layout requires modification to the wheelbase, it is essential to consult the Product Applications Department. Each case has to be covered by a specific design.
- 4** The certificate will be issued in accordance to the legislation in force regarding modifications made by and under the responsibility of the bodybuilder, within the limits stipulated by the Manufacturer and relative to:
 - the wheelbase
 - the distribution of loads
 - the cab characteristics.
- 5** For more accuracy in your calculations, we recommend you to introduce into the data the weighed weight of the chassis cab to be equipped (capable of varying according to manufacturing tolerances and the various options available). The same applies to equipment for which the manufacturers can accurately define the weight and the position of the centre of gravity.

1.13.2 Body fitting certificate

This defines the installation of the equipment on the chassis cab and the unladen weight imposed on the axles and then the weight when fully laden.

It must be attached to all applications relating to the equipment which do not comply with any of the dimensions set out in the descriptive sheet.

1.13.3 Responsibility for installation

The building and fitting of a body on a vehicle is the sole responsibility of the bodybuilder, who must comply with the recommendations in the present document.

He must ensure that the installation of the body does not affect the functions or the reliability of the components or the road behaviour of the vehicle.

1.14 Painting

1.14.1 Precautions

- Protect the RENAULT V.I. equipment (i.e. by using screens, self-adhesive tape, cab cover etc.)
- Never put vehicles into drying ovens at a temperature of more than 80° C.
- The chassis of the vehicle must be electrically earthed to allow static electricity to run away to earth (protection of electronic boxes).
- The vehicle must be protected against corrosion by paints compatible with those used by our Company and conforming to RENAULT V.I. Specification No 4702 441 (protection of bodywork and equipment adapted to RENAULT V.I. vehicles) available from the Product Applications Department.
- Thinner solvents must never be used on cables and electrical sheaths.
- Protect the identification marking of electrical wires and compressed air pipes.

Never paint bearing surfaces of brake drums and disc wheels, or with twin tyre fitment, the assembly surfaces between the disc wheels. As a general rule, do not repaint the support surfaces of original fitment nut and bolt hardware and comply with the specification.

NOTE

Our Product Applications Department holds the reference numbers for paint colour shades for chassis and cabs at your disposal. These paint colours can be procured as "spare parts" and can be ordered from our dealers.

The cab colour shade is indicated on the front end of the cab.

Since 1994, chassis and accessories are no longer sprayed with the customer's shade of paint at the time of original fitment.

To preserve the aspect and original quality, it is essential to observe the following methods after fitting equipment, body, sub-frames and various adaptations to major units or chassis frame:

1.14.2 Major units (gearboxes, drive axles, engines, axles, etc.)

Works paint: GLYCEROPHTHALIC

Retouch (after fitting PTO, charge indicator, etc.)

Retouch method

- Clean with a universal cleaner or using a high-pressure cleaner.
- Wipe down, then apply a primer.
- Let the product cure until mat (about 15 minutes at 20° C), then apply the corresponding polyurethane lacquer.

1.14.3 Chassis frame and accessories (sidemembers, crossmembers, fittings, lockers, etc.)

Works paint: POLYURETHANE or POLYESTER powder.

Retouch method:

Superficial scratches (the metal is not affected).

- Clean with a universal cleaning product.
- Wipe down, then apply the corresponding undiluted but catalyzed polyurethane lacquer, using a small brush.

Deep and fine scratches (down to the bare metal).

- Clean with a universal cleaning product.
- Wipe down, then apply the primer, using a small brush.
- Let the product cure (about 15 minutes at 20° C), then apply the corresponding undiluted but catalyzed polyurethane lacquer.

Deep and wide scratches (down to the bare metal, drilling of sidemembers for attaching tail lifts and accessories) due to drilling.

- Rub down.
- Clean with a universal cleaning product.
- Let the product cure until mat (about 15 minutes at 20° C), then apply the corresponding polyurethane lacquer.

Making good after conversion (after converting wheelbase and overhang).

- Grind, rub down; prepare the area in question (burnt paint, welding scale, etc.).
- Clean with a universal cleaning product or using a high-pressure cleaner.
- Mask with tape (electrical wiring harnesses, air and fuel pipes, labels, etc.)
- Wipe down, then apply the primer.
- Let the product cure until mat (about 15 minutes at 20° C), then apply the corresponding polyurethane lacquer.
- After drying, put back the electrical wiring harnesses, air and fuel pipes and accessories.

Spraying chassis and accessories (with customers colour shade).

- The bodybuilder undertakes to preserve the aspect and quality of the original fitment vehicle (except for nut and bolt hardware).
- Clean with a universal cleaning product or using a high-pressure cleaner.
- Mask with tape (electrical wiring harnesses, air and fuel pipes, labels, etc.)
- Wipe down, then apply the primer.
- Let the product cure until mat (about 15 minutes at 20° C), then apply the corresponding polyurethane lacquer.
- After drying, put back the electrical wiring harnesses, air and fuel pipes and accessories.

NOTE

All spray gun operations are to be carried out in a painting booth.

Since August 1999, the chassis are painted grey as replacement for Enduro red. For paint retouches on grey chassis, use a grey paint aerosol ref. N° 50 01 848 147.

1.14.4 Recommended products

Manual cleaning

Universal cleaning product or equivalent solvent

Products approved by RENAULT V.I.

Supplier	Commercial name	RENAULT V.I. Ref.	Supplier Ref.
BASF	PK 900	50 01 821 758	SV 20023F
ICI AUTOCOLOR	Slow Spirit Wipe	50 01 854 983	P850-1402
STANDOX	ENTFERNER Agent	50 01 825 985	FA 931 2002

High-pressure cleaning

Degreaser, phosphater degreaser

Filing and sealing

Products approved by RENAULT V.I.

Supplier	Commercial name	RENAULT V.I. Ref.	Supplier Ref.
STANDOX	"EPOXY" filler-sealer	50 01 826 019	FA 931 5203
	"EPOXY" hardener	50 01 825 990	FA 931 5204
	"EPOXY" thinner	50 01 826 005	FA 931 5205
	"EPOXY" slow thinner	50 01 829 256	FA 931 5213
	thinner 2KS	50 01 825 992	FA 020 7810
ICI AUTOCOLOR	"EPOXY" filler-sealer	50 01 829 477	P580-2100
	"EPOXY" hardener	50 01 829 480	P210-833
	thinner	50 01 829 481	P850-3091

Finish paint

Two-component polyurethane paint and corresponding thinner.

1.14.5 Marking of polymer components (recycling of plastics)

Plastic parts are marked so as to simplify their sorting during recycling at the time when the vehicle is scrapped at the end of its life.

Marking of the plastic parts is done by placing abbreviated terms for the polymer components between the symbols ">" and "<". The parts are marked on a face which the customers cannot see and when it is possible the marking is indelible. Marking is done in the following manner:

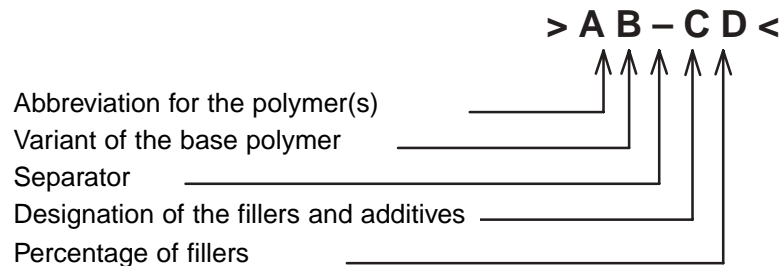

Marking of single component products

The abbreviated term for the material is enclosed in symbols ">" and "<".
For example: ">PP<" or "PP" indicates polypropylene.

Marking of copolymers

The abbreviated terms for the polymers are separated by a "/".
For example: ">P/E<" indicates the copolymer propylene ethylene.

Marking of mixtures or blends of polymers

The abbreviated terms are separated by a "+" (heterogeneous structure).
For example: ">PP + EPDM<" stands for a blend of polypropylene and EPDM.

Marking of polymers with fillers (additives)

The abbreviated term for the polymer is separated from that for the filler by a dash "-".
The number following the abbreviated term for the filler relates to its percentage in the mixture.
For example: ">PA66 - (GF25 + MD15)<" indicates polyamide 66 with 25% filler and 15% reinforcement with mineral fillers (in decreasing order of percentage).

Marking of multi-component products

The abbreviated terms for the components are separated by commas, in order of appearance (firstly the surface material).
For example: ">PVC, PUR, ABS<" indicates skin surface PVC on PUR foam with an ABS insert.

Marking of special features

Abbreviated terms for the polymers can be added up to 4 symbols, in order to indicate a modification.
The symbols are put in after the abbreviated terms.
For example: ">PE - C<" indicates chlorinated polyethylene, ">PE - LLD" stands for linear low density polyethylene.

Table of the principal polymers

Abbreviated term	Variant	Materials
A.B.S		Acrylonitrile/butadiene/styrene
A.S.A		Acrylonitrile/styrene/acrylate
E/P		Ethylene/propylene
E.P.D.M		Copolymer ethylene/propylene/diene
P.A		Polyamide
P.A	6	Polyamide 6
P.A	66	Polyamide 66
P.C		Polycarbonate
P/E		Propylene/ethylene
P.E		Polyethylene
P.E	– HD	High density polyethylene
P.E	– LD	Low density polyethylene
P.E	– LLD	Linear low density polyethylene
P.E	– X	Cross-linked polyethylene
P.M.M.A		Poly(methacrylate of methyl)
P.O.M		Polyoxomethylene
P.P		Polypropylene
P.P.E		Poly(phenylene ether)
P.P.O.X		Poly(oxide of propylene)
P.S		Polystyrene
P.S	– HI	Impact polystyrene
P.T.F.E		Poly(tetrafluoroethylene)
P.U.R		Polyurethane
P.V.C		Polyvinyl chloride
P.V.C	– C	Chlorinated polyvinyl chloride
P.V.C	– P	Plasticized polyvinyl chloride

1.15 Electrical equipment

1.15.1 General

- Any mounting of a specific item of equipment on a commercial vehicle must be in conformity with the recommendations of RENAULT V.I. and the legislation in force. Its execution remains the entire responsibility of the bodybuilder, both with regard to the suitability for the vehicle being equipped and any possible electromagnetic interference.
- For reference to wiring diagrams, consult the electrical equipment workshop manual for the vehicle (available from the Spare Parts Department of RENAULT V.I.).
- Check that the electrical consumption of this equipment is appropriate for the capacity of the batteries and also the charging current rate of the alternator (if not, refer to the recommendations of the manufacturer CIC 1081). For the fitting of any particular equipment, consult the Product Applications Department of RENAULT V.I.
- A schematic diagram should be submitted for the approval of RENAULT V.I., when raising any specific question.
- A wiring diagram for the bodybuilder's or equipment manufacturer's installation must be incorporated into the vehicle driving and maintenance handbook. The electrical connection points for the equipment being supplied should be clearly and precisely indicated on this wiring diagram (even after the agreement of RENAULT V.I. has been obtained).
- Follow the electrical protection recommendations of RENAULT V.I.; it is forbidden to change the rating of fuses.
- In order to harmonize vehicle equipment, you should use in preference such items as are identical to those fitted in the basic vehicle (i.e. indicator lamps, controls, relays, etc.).
- Assembly of a protective shield on the electric retarder is compulsory for ADR (Transport of Hazardous Substances) vehicles (refer to regulations in force).
- It is compulsory for the supply voltage for the equipment installed to be equal to the rated voltage of the vehicle. The installation of equipment with a 12 volt power rating on our vehicles (24 volt rated voltage) is not permitted unless a voltage dropper is added.
- Under the circumstances that additional lamps are fitted, the installation must not damage the fluidtight sealing of the junction boxes.
- Operating without a battery is forbidden.

1.15.2 Wiring harnesses

- Use to the full the wiring runs already set up by the manufacturer (i.e. conduits, tubes, sleeves, etc.) and comply with the limit of their capacity.
- Any wiring harness added by the bodybuilder must be protected by a sealed sheath (smooth and thick or ringed) and can be routed along with the original wiring runs for the vehicle provided that it does not adversely affect the mechanical mountings for the original harnesses. For vehicles for the transport of hazardous goods, use the protective equipment authorized by the regulations covering the transport of hazardous goods.
- If you are obliged to route wires close to a source of heat (i.e. engine, exhaust system, etc.), the minimum clearance to be complied with is 200 mm.
- Never route a wiring harness over projecting angles.
- Never attach a wiring harness to moving parts (even slight movement).
- The section of the cables being used must be suitable for the use in question. Their cross-section should be selected in accordance with the maximum current on-line (5 amperes per mm²).
- The length of the wiring harnesses should be long enough to allow the electrical appliance which is connected to be taken off (i.e. principal display unit, tachograph, etc.).
- The numbering of the wires must be in accordance with the manufacturer's standard.
- The link between the sheath and the connector must be fluidtight.

1.15.3 Electrical connections

- Any additional connection requires protection that is suitable for the use for which it is intended (even if the power supply provided for the customer by RENAULT V.I. is already protected by a fuse).
- Any electrical connection must be properly wired on the power lines supplied by the manufacturer to the bodybuilder's equipment (refer to the servicing and maintenance handbook for the vehicle in question).
- Tapping into the various wiring harnesses supplied by RENAULT V.I. is completely FORBIDDEN (for example vehicle rear lamps, external marker lamps, contactors, pressure switches, relays, electronic box inputs and outputs, etc.)

Reminder: a 12 V tapping at the middle point between the two batteries is strictly FORBIDDEN.

- The electrical connections of the various wiring harnesses of the bodybuilder must be made using a fluid-tight junction box or otherwise using sealed connectors. If connections have to be made on circuits hooked up to electronic equipment:
 - Ensure that you comply with the polarity recommended.
 - No inductance current must pass through the circuits which have been added.
 - All the earths must be connected up to the available "EARTH" points provided and not to the bodywork of the vehicle.
 - After work on junction boxes, the seal must always be as integrally effective as the original seal.
 - Any power supply requiring a direct connection to the batteries must be capable of being isolated by a battery cut-out (for example: tail lifts) and protected by a fuse sited as near as possible to the batteries. Suitable connection terminals should be used.
 - The + power supply is taken from the master switch, or failing this, from the battery terminal for vehicles without a master switch, but in no case from the alternator or starter motor terminal.
 - Power supplies to auxiliary equipment: i.e. telephone, fax, etc. The quality of the installation is the responsibility of the installer (i.e. reception, static, interference, etc.)
 - Preferably, you should use connectors approved and distributed by RENAULT V.I. (i.e. type, sealing properties, rating, number of channels, etc.)
 - Connectors for equipment should be positioned near the bottom, whilst avoiding areas subject to splashing (i.e. wheelarches, etc.).

1.15.4 Available power supplies

All our vehicles are equipped with the available power supply protected by fuses and these are at the disposal of bodybuilders and equipment manufacturers.

These power supplies are described in the vehicle driving and maintenance handbook (supplied with every vehicle), in the Workshop Repair Electrical Manual, and in this document (all these documents are available from the RENAULT V.I. dealer network).

1.15.5 Flasher units

Should the flasher unit become inoperative due to failure to comply with the instructions contained in this document, the coverage granted by the warranty will be lost.



The flasher units are designed for a maximum rating which is marked on the unit.





Do not exceed this power rating.

Connection

In order to make the connections correctly, consult either the identification marks which are located close to the terminals, or the wiring diagram on the label which is affixed to the flasher unit cover.

1.15.6 List of standard power sockets

SUPPLY VOLTAGE	DESCRIPTION AND STANDARDS	SOCKET DIAGRAM (front view)
12 Volts	<p>12 N type socket (Standard: - BNA.R.43.407 dated April 1982 - ISO 1724).</p> <p>1 - LH direction indicator lamp. 2 - Rear fog lamp. 3 - Earth. 4 - RH direction indicator lamp. 5 - RH rear side and marker lamp and number plate illumination lamp. 6 - Stop lamp. 7 - LH rear side and marker lamp and number plate illumination lamp.</p>	 <p style="text-align: center;">600037</p>
12 Volts	<p>12 S type socket (Standard: - BNA.R.43.410 dated August 1982 - ISO 3732).</p> <p>This is a supplementary socket which is assembled in addition to the 12 N socket.</p> <p>1 - Reversing lamp. 2 - Not allocated. 3 - Earth. 4 - Supplementary + power supply. 5 - Earthing monitor. 6 - Positive (+) power supply. 7 - Not allocated.</p>	 <p style="text-align: center;">600038</p>
24 Volts	<p>12-pin socket (Standard: - BNA.R.43.405 dated March 1961 - DEFA 1457 b - DCEA 5.556 - NATO).</p> <p>A - LH black-out side lamp. B - LH direction indicator lamps. C - RH black-out side lamp. D - Earth E - Rear side and marker lamps and number plate illumination lamp. F - Black-out stop lamp. H - Not allocated. J - RH direction indicator lamps. K - Battery + power supply. L - Earth. M - Stop lamps. N - Not allocated</p>	

SUPPLY VOLTAGE	DESCRIPTION AND STANDARDS	SOCKET DIAGRAM (front view)
24 Volts	<p>24 N type socket (Standard: - BNA.R43.406 dated January 1976 - ISO 1185).</p> <p>1 - Earth. 2 - LH rear side and marker lamp and number plate illumination lamp. 3 - LH direction indicator lamps. 4 - Stop lamps. 5 - RH direction indicator lamps. 6 - rear side and marker lamps and number plate illumination lamp. 7 - Trailer braking lamp. Terminal 7 is scheduled in certain countries for supplying power to regulation trailer brakes. Under no circumstances must it be used as an earth terminal.</p>	 <p style="text-align: center;">600043</p>
24 Volts	<p>24 S type socket (Standard: - BNA.R43.409 dated April 1982 - ISO 3731).</p> <p>This is a supplementary socket which is assembled in addition to the 24 N socket.</p> <p>1 - Earth. 2 - Not allocated. 3 - Reversing lamp. 4 - Power supply. 5 - Earthing monitor. 6 - Supplementary power supply. 7 - Rear fog lamp.</p>	 <p style="text-align: center;">600041</p>
24 Volts	<p>24 P (oil tanker) type socket (Standard: - BNA.R.10.120 dated June 1977)</p> <p>This is the socket for ADR (Transport of Hazardous Substances) vehicles which is assembled in addition to the 24 N socket.</p> <p>1 - Earth. 2 - Valve lighting. 3 - Reversing lamp. 4 - Positive (+) power supply. 5 - Insulated earth. 6 - Not allocated. 7 - Rear fog lamp.</p>	 <p style="text-align: center;">600042</p>
24 Volts	<p>ABS specific type socket (Standard: - ISO 7638)</p> <p>1 - Power (30A). 2 - Control power supply (2A). 3 - Control earth (2A). 4 - Power earth (30A). 5 - Information (2A). 6 - Free. 7 - Free.</p>	 <p style="text-align: center;">600583</p>

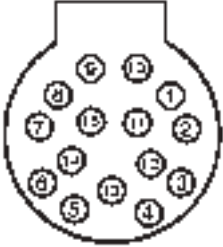
SUPPLY VOLTAGE	DESCRIPTION AND STANDARDS	SOCKET DIAGRAM (front view)
24 Volts	<p>15-pin trailer socket (Standard: - ADR 1999 IP54 and anti-unhooking - ISO 12098).</p> <p>1 - LH direction indicator lamps 2 - RH direction indicator lamps 3 - Rear fog lamp 4 - Earth 5 - RH rear side/parking and marker and registration plate lamps 6 - LH rear side/parking and marker and registration plate lamps 7 - Stop lamps 8 - Reversing lamps 9 - 24V positive (+) power supply Since July 1999, the 15-way socket replaces 24N and 24P sockets. Channels 10, 11, 12, 13, 14, 15 are unaffected.</p>	

The 15-way socket can be mounted on vehicles equipped with 24N and 24P sockets with the use of a 15-way 24N/24P adapter ref. N° 50 01 851 060 available from the RENAULT V.I. Spare Parts department.

1.15.7 Additional direction indicator lamps

- On tractors and rigids

Should the lamps provided not meet all the requirements of the legislation in force, the bodybuilder may add extra lamps supplied with power by the same circuit as the front lamp or by a special circuit should one be available from the flasher unit. In all cases, comply with the power rating.

We strongly advise you to refrain from fitting any other lamp not required by the regulations.

- On trailers and semi-trailers

The standards in force concerning trailers require only two circuits for the flasher units: one circuit for the RH side and the other for the LH side. No additional lamps must be fitted on the trailer or semi-trailer which run from the monitored trailer lamps.

The addition of extra lamps entails the fitting of new wire runs which have to be drawn from the non-monitored lamp terminals in the flasher unit.

Overloading

Under no circumstances must extra lamps be fitted that exceed the power rating on the flasher unit. The main consequences of such overloading are as follows:

- The service life of the flasher unit is shortened, even when it would appear to be operating normally in spite of the overload.
- Operation is adversely affected by intermittent or permanent sticking of the contacts (the lamps remain lit without flashing)
- The appliance may be **off-circuit for the duration of the overload.**

Protection of the flasher unit (depending on the vehicle equipment)

In the event of excess current, the flasher unit will cease to operate. To return it to service:

- Move the flashing lights control switch to the 0 "off" position.
- Find the cause of the overcurrent (lines or lamps) and remedy it.

You will then be able to use the flashing lights again normally.

1.16 Air-operated equipment

Should it be necessary to add auxiliary equipment not provided by the manufacturer, it must compulsorily be connected to the circuit specifically provided for auxiliary equipment on the vehicle.

The compressed air consumption of such auxiliary equipment should under no circumstances compromise the filling times of the brake circuits laid down by the legislation in force.

The RENAULT V.I. Product Applications Department is at your disposal for any further information you may require.

1.16.1 Regulations

It is forbidden to modify officially approved braking circuits which conform with the standards set out by the Highway Code.

Any modification, without prior agreement from RENAULT V.I., is done under the sole responsibility of the author of such a modification.

1.16.2 Polyamide pipes

Identification marking

Before removing any equipment or disconnecting polyamide pipes, mark the pipe in relation to the connection port on the equipment.

Coding system used on polyamide pipes (RENAULT V.I. standard):

Polyamide pipes are identified with a colour code marked with adhesive tape or by elastic rings.

Brakes code:

Main functions	Sub-functions		
	Constant pressure	Delivered pressure	Signalling pressure
Front service brake	Orange	Orange - White	Orange - Yellow
Rear service brake	Blue	Blue - White	Blue - Yellow
Parking brake	Green	Green - White	Green - Yellow
Trailer brake	Red	Red - White	Red - Yellow
Extra brake	Yellow	Yellow - White	Yellow - Yellow

Coding used on pneumatic appliances (DIN standard)

0 - Air intake	5 - Free		
1 - Pressurized supply	6 - Free		
2 - Delivered pressure	7 - Antifreeze		
3 - Air vent	8 - Lubrication.	81 - Inlet.	82 - Outlet
4 - Signalling pressure	9 - Water cooling.	91 - Inlet.	92 - Outlet

When the figure is followed by a second figure, the latter figure indicates the sequence number.

Example: 41, 42, 43: The figure 4 indicates the signalling function, the figures 1, 2, 3 indicate a sequence number in that function.

Replacement of a brake line

The entire length of a damaged polyamide pipe should be replaced by a pipe with identical characteristics (length and diameter), and corresponding with the standard in force. (See technical memo 8655 group 53000, part N° 50 20 034 156 available with spare parts). It must also be provided with coloured rings which are identical to those of the tube replaced.

Use an original manufacturer's pipe available from the RENAULT V.I. Spare Parts warehouse.

The routing of a polyamide pipe must be carefully executed. Ensure there is no interference with sharp-edged metal parts and there is no routing close to high temperature units. The pipes must be held at regular intervals by plasticized clamps or run in existing ducting. Non-plasticized attachment clamps are absolutely forbidden. Take care to ensure the minimum radius of curvature of polyamide pipes is observed.

Dimension	4 x 6	6 x 8	9 x 12	12 x 16
Radius of curvature	30 mm	50 mm	70 mm	130 mm

Modification to the length of the chassis

Modification to brake pipe lengths requires braking response times to be checked out, in accordance with the legislation in force, and with agreement from the Type Approvals Department.

Connections for ratchet type pneumatic brake pipes type "RILAX 2000"

For the fitting of this type of connector, refer to and comply absolutely with the technical instruction sheet NT 8852 (method and tooling) available from the RENAULT V.I. Spare Parts Department.

2. GENERAL RULES TO BE OBSERVED WHEN FITTING BODYWORK

Before carrying out any work, protect the cab with a cover.

Our vehicles are equipped with plates, U-bolts or brackets. Preparation work may involve extra drilling or welding.

The principles described below must be adhered to.

2.1 General principles of welding

2.1.1 Precautions

Protection of the batteries

A battery at the end of its charge produces a mixture of oxygen and hydrogen gas. The ignition of this gas presents dangers of battery explosion in the case of the presence of a source of heat nearby. As a result, during a welding operation near the batteries (i.e. engine compartment, front end of the vehicle), take out the batteries and store them in a well-aired location away from the place where welding is being done. This recommendation applies equally for grinding operations.

Soundproofing screens

In the case of welding or use of a disk sander, either provide effective protection or remove the soundproofing screens, if necessary.

Protection of electrical and mechanical components

The vehicle is equipped with numerous electronic circuits: alternator, regulator, flasher units, speed limiter, ABS, etc.

Before any operation involving electric arc welding, make an earth connection by disconnecting the two negative (-) and positive (+) cables from the battery (starting with the earth cable) and connecting them to the frame earth. If the vehicle is equipped with a master switch, this should be kept engaged (circuit closed). Place the earthing clamp as near as possible to the point of welding, but never on rotating parts (prop shaft, fan hub, etc.) or on a subassembly having moving parts (i.e. air compressor, turbocharger, etc.)

Nearby plastic pipes and electrical cables, springs and air-suspension bags are to be protected or removed. This also applies when grinding or drilling.

When reconnecting the battery, observe the polarities, commencing with the positive (+) terminal. Reversal of polarity may cause irreparable damage to electronic components.

2.1.2 Preparation of parts for welding

Clean the parts, primarily at the location of the weld and at the connection of the earthing wire. This allows:

- free and regular electrical current flow (regularity of weld bead),
- avoidance of inclusion of impurities in the molten metal (weld quality),
- avoidance of spatter and emission of smoke (safety for the welder).

For conversions (extensions, reductions and reinforcement gussets), we recommend arc welding with electrode type B. When semi-automatic welding is used, the bodybuilder must be able to guarantee weld quality.

Preparation of specific edges on chassis frames

- A - With electric arc welding
- B - With weld under gas shield (MAG or MIG)

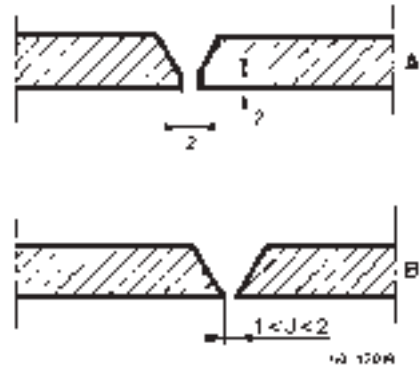

Method of welding to be specifically used on chassis frames

- Preparation of the edges at 45°
- Tack
- Position slave butts
- Weld on one single side
- Weld on second side
- Welds ground flush on both sides

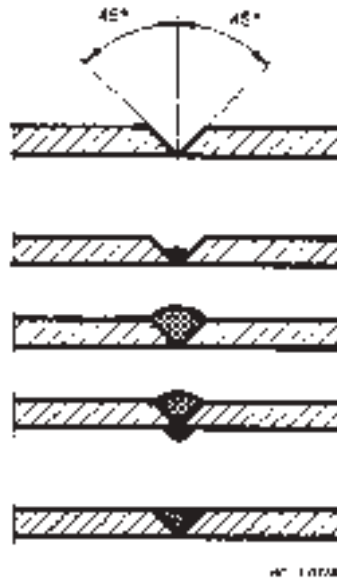

Slave butts

The object of slave butts is to avoid the starting of cracks at the outside edges of the weld joint. Before final welding align butts with plates of the same thickness as the plates to be joined, holding them in position using quick action clamping devices.

They must not under any circumstances be held in position by weld tacks on the plates to be joined.

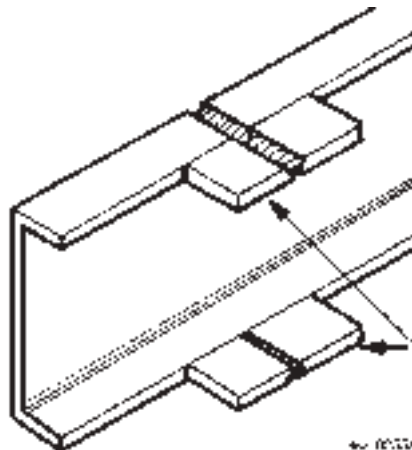

2.1.3 Welding process

Static or rotary arc welding set

- dc welding set recommended
- coated welding rods

Welding rod usage table

Electrode diameter (in mm)	2.5	3.15 (*)	4 (*)	5
Average current (in amperes)	75 to 90	95 to 110	120 to 140	150 to 175

(*) Most frequently used diameters

Coated welding rods recommended: standard NF EN 499 (January 1995)

EN 499 E 38 2 1 NI B for class: A - B - C

EN 499 E 46 2 1 NI B for class: D - E

EN 499 E 50 2 1 NI B for class: F

E 515/5 B 26 BH for steels class F

If steels are mixed, take the best performing steel electrode category.

Standard **NF EN 499** replaces standard NF A 81-309.

Relevant standards

AFNOR A 81.309 (12.1975)	ISO 2560	ASME (SFA 5.1) AWS (AS.1.69)	DIN 1913	BS 639
E 435/4 B 26 BH	E 435 B 26 (H)	E 7016	E 453/4 B 10	E 435 B 26 (H)
E 515/5 B 26 BH	E 515 B 26 (H)	E 7018	E 515/5 B 10	E 515/6 B 26 (H)

MIG or MAG semi-automatic welding set

MIG: - Metal Inert Gas

- for welding with electrode wire under inert gas shield (Argon, Helium...)

MAG: - Metal Active Gas

- for welding with electrode wire under active gas shield (CO₂, Argon + CO₂, Argon + CO₂ + O₂).
- used for welding mild steels.

Wire diameter (in mm)	Thickness to be welded (in mm)
0.8	up to 2 mm
1.0	from to 8 mm

2.1.4 Equivalent steel grades

The four classes relate to hot rolled steel plate with a high yield strength for cold forming, as currently set out in the French and European Standard NF EN 10149-2, which has replaced French Standard NF A 36.231. High yield strength sheet steel (dispersed carbon)

RENAULT V.I. Specification 31.09-402				
	Class C	Class D	Class E	Class F
UTS in N/mm ² min.	450	500	540	610
YP at 0.2% in N/mm ² min.	355	445	490	560
E % min.	23	20	18	15
KCV at - 20°C J/cm ² min., longitudinal	35	35	35	37,5
Bending, transversal	1 e	1 e	1.5 e	1.5 e
Grain size	n° 5	–	–	–
= European equivalent French standards	S 355 MC NF EN 10149.2	S 420 MC NF EN 10149.2	S 500 MC NF EN 10149.2	S 550 MC NF EN 10149.2
= German standards equivalent DIN	QStE 380TM SEW 092	QStE 420TM SEW 092	QStE 500TM SEW 092	QStE 550TM SEW 092
= British standards equivalent BS	43 F 35 BS 1449	46 F 40 BS 1449		
= American standards equivalent ASTM	Gr. 50 050 YKL ASTM 607–50	Gr. 60 060 YKL ASTM 607–55	Gr. 70	Gr. 80
= EURONÖRM standards equivalent 149-80	FeE355 TM	FeE420 TM	FeE490 TM	Fe E560 TM

2.2 Reinforcement, extension, reduction of sidemembers

2.2.1 Bans

It is absolutely forbidden to weld onto sidemembers, except for reinforcement, extension, reduction, and the following instructions must be observed:

- Do not weld on the edges of flanges.
- Do not weld in sidemember bending radii.
- In the case of flat irons: no directly opposing welds on the two faces of the same web - only "alternate" or "plug" welds are authorized.
- No welds which are less than 15 mm from the edge of a hole.

Insofar as possible, we advise you to have modifications of the lengths of sidemembers carried out by specialists.

- The general rules for welding in the paragraph entitled "General Principles of Welding" must be strictly followed.

Only conversions (extensions or reductions) rendering the modified vehicle completely in conformity with a type approved chassis are permitted without additional testing, with certification from the vehicle manufacturer.

2.2.2 Reinforcement of sidemembers

- For inner reinforcements and chassis flange stiffeners, the thickness should be the same as the thickness of the sidemember.

NOTE

The steel grade must be identical to that used for the sidemember.

Examples of reinforcements

Sidemember upper and lower stiffeners

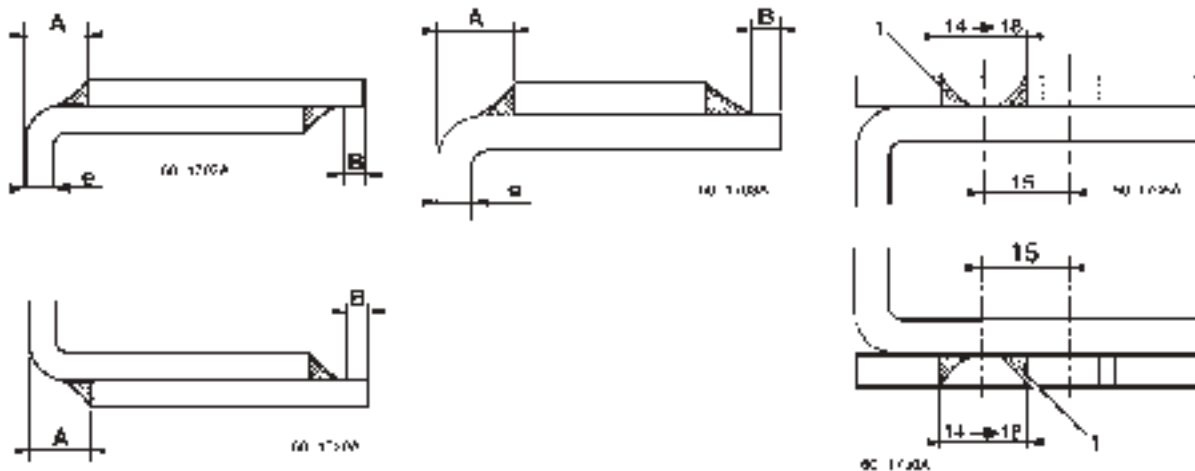

A: Offset of the stiffener in relation to the external face of the sidemember

B: Offset of the stiffener in relation to the edge of the sidemember

e: Thickness of the sidemember

1: Welds through round or slotted holes, staggered

Thickness of the sidemember	A	B
$e < 6 \text{ mm}$	10 mm	15 mm
$e \geq 6 \text{ mm}$	15 mm	15 mm

Upper and lower stiffeners using angle-irons :



60 1203

Method of joining

In the case of stiffeners made from flats (on the upper flange or under the lower flange of sidemembers), we recommend attachment by:

Intermittent beads by electric welding: as guidance, 80 mm beads spaced 120 mm apart and staggered.

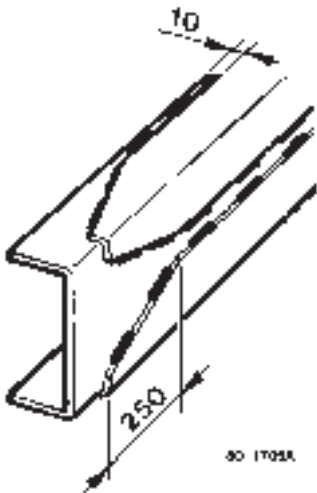

60 1705A

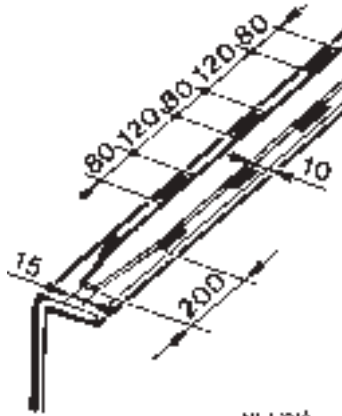

60 1705B

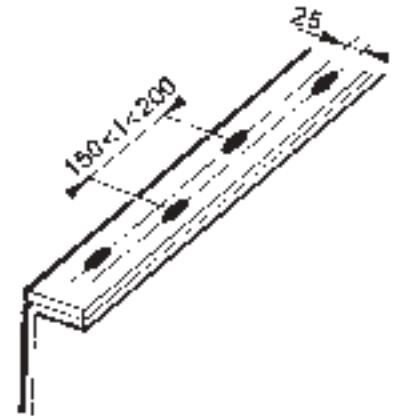

60 705A

“PLUG” welds: as guidance, round holes diameter 14 to 18 mm or slotted (1) holes diameter 14 x 50 mm to 18 x 50 mm at a “pitch” of 200 mm min. to 300 mm. max., staggered, with good quality weld.

WARNING

No vertical welds on sidemember webs. No transversal welds on sidemember flanges.

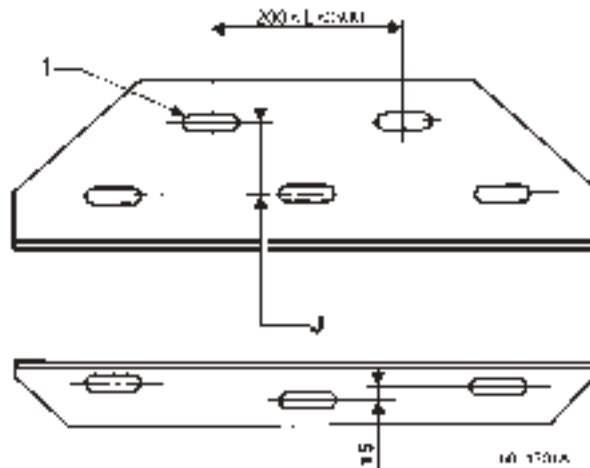

60 1705A

Extension, shortening of sidemembers in the wheelbase

Key

- A – piece of sidemember added,
- B – sidemember,
- C – reconstituted stiffener,
- D – welds projecting beyond flanged edge with butt-ends then longitudinal grinding (elimination of sharp edges),
- e – thickness of the sidemember,
- F – angle-iron of thickness (E) max.: $E \leq (e - 1 \text{ mm})$,
- h – height of the sidemember,
- J – weld penetration clearance (about 2 mm),
- L – max. length of extension,
- X – max. length of projection of the stiffener measured on the edge of the flange (extension),
- Y – min. length of support of the stiffener measured on the edge of the flange of the sidemember (extension),
- Z – min. length of support of the stiffener measured on the edge of the flange (stiffener without extension).

Extension of the sidemembers in the wheelbase

Sidemember without stiffener flat on the flange

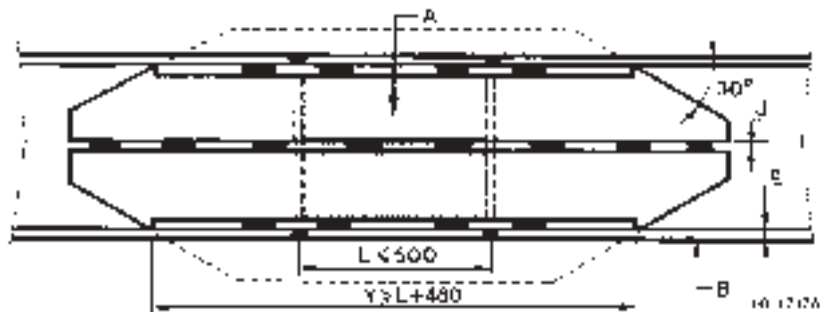

Sidemember with stiffener flat on the flange

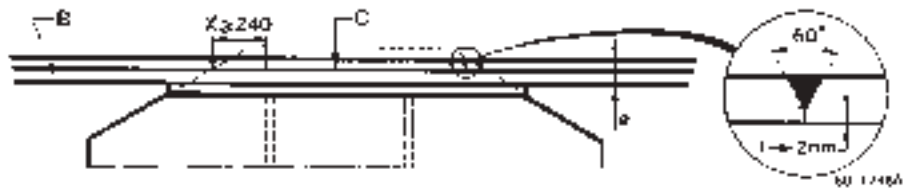

Shortening of sidemembers in the wheelbase

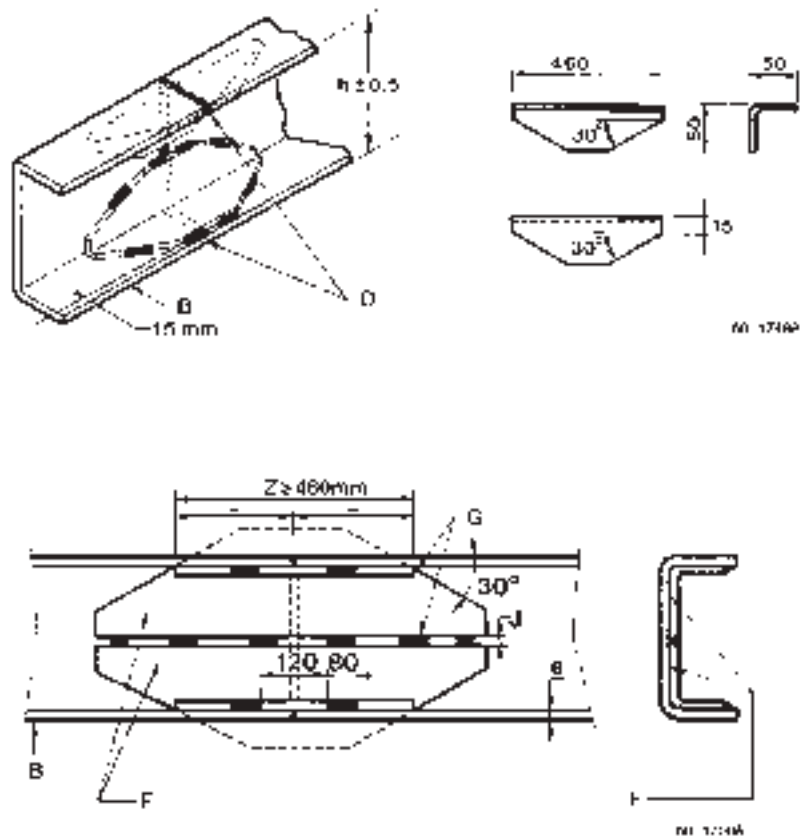

2.2.3 Modification of the rear overhang

If the bodywork or the equipment fitted do not alter the weight and dimensional characteristics of the chassis entered on the description sheet, the vehicle can be submitted to the Type Approval Department without any action being necessary on the part of RENAULT V.I. (within the permitted limits in force).

- Welding stiffeners are required for drawbar rigids or if the extension is longer than 400 mm for a solo vehicle. Examples: Drawbar rigid; tail lift; crane at the rear of the chassis; tipper; etc.
- Extension of the rear overhang will also be required when the rear extremities of the bodywork project beyond the maximum authorized value which is indicated on the bodybuilder's drawing and calculation sheets relating to the vehicle.

Attachment of crossmembers

Crossmembers should be attached with nut and bolt hardware of the 10.9 S2S protected class as per standard 01714002 and distributed by RENAULT V.I.

Towing crossmembers

Please refer to the chapter on "Drawbar crossmembers" in the section entitled "SPECIFIC FEATURES OF THE MIDLUM VEHICLE".

Intermediate crossmembers

In the case of extension of the wheelbase or the rear overhang, it is essential to add crossmembers, so as not to weaken the rigidity of the frame.

Observe the following instructions:

- Between two crossmembers, the spacing must be no greater than the original spacing.
- If the extension to the overhang is longer than 500 mm, the rear crossmember must be moved and an intermediate crossmember fitted which is identical to the others.

2.3 Attachment of bodywork

The bodywork must be correctly attached so that both the static and dynamic stresses are freely transmitted without causing excessive local strain, which could prejudice the reliability of the chassis frame or affect the road behaviour of the vehicle.

The following rules apply to the fastening of various standard bodies fitted to our chassis cabs, such as platforms, vans, tippers, and tankers. For special cases, contact the Product Applications Department.

For body design (i.e. length, load distribution, location of accessories on sidemembers, etc.) refer to the CD-ROM "Information for Bodybuilders" or the 1:20 scale bodywork drawing which we supply upon simple request.

Fastenings should always be tightened progressively and alternately.

The shape of sub-frames or underbodies should always be tapered towards the front (i.e. at the back of the cab), so as to avoid sudden variations in inertia (refer to chapter entitled "Finishing of sub-frame behind the cab").

2.3.1 Bans

- The use, drilling or welding of spring hangers.
- Any modification of: the chassis, the driveline, or the suspension.
- Fastening of sub-frames to our sidemembers by welding.
- The drilling of stiffener gussets.
- The notching of sidemembers, gussets or crossmembers.
- With the exception of special cases described in this document, the use or modification of our nut and bolt hardware and our riveting for the attachment of a body or sub-frame.
- The attachment of sub-frames by hooks (use U-bolts).

All bodies attached by clamps and brackets must mandatorily have 1 inertia stop to the aft of each sidemember to stop the body from moving in the event of fierce braking, as well as 4 body guides 2 at the front, 2 at the rear).

For bolted fastenings, comply with the following instructions:

- By preference use brackets attached to the chassis.
- Use the fixing bolt holes 11, 13 or 15 mm diameter depending on the particular vehicle, spread out along the length of the sidemembers of the chassis frame.
- Take good note of the attachment principles, set out in the chapter on the "Attachment of sub-frames".

2.3.2 Protection against exhaust heat radiation

Depending on the features of your bodywork or equipment, the fitting of a heat shield on the original protection is recommended.

2.4 Sub-frame

In order to attach bodywork to the frame of the chassis, you should allow for the fitting of a sub-frame whose module of inertia (I/V) is determined in accordance with the vehicle series in question (refer to the section entitled "MIDLUM special bodybuilding features").

In order to ensure better distribution of the stresses along the sidemembers, you must allow for a cut-out as far forward as possible under the cab.

2.4.1 Finishing of sub-frames behind the cab

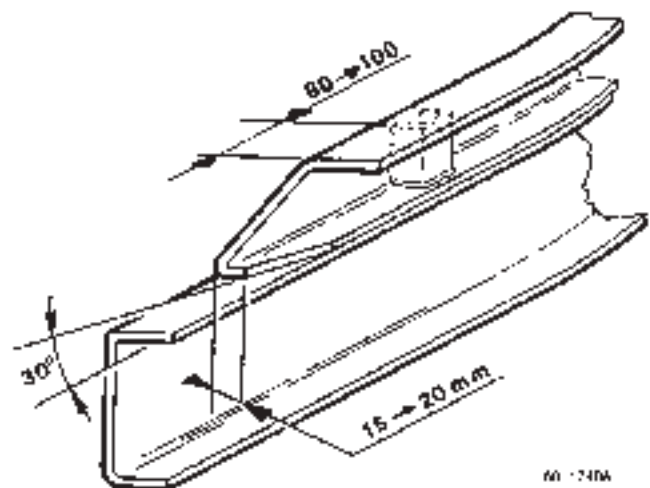
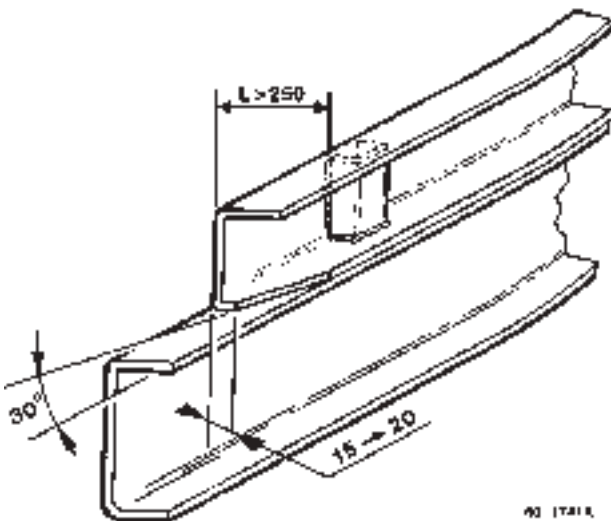
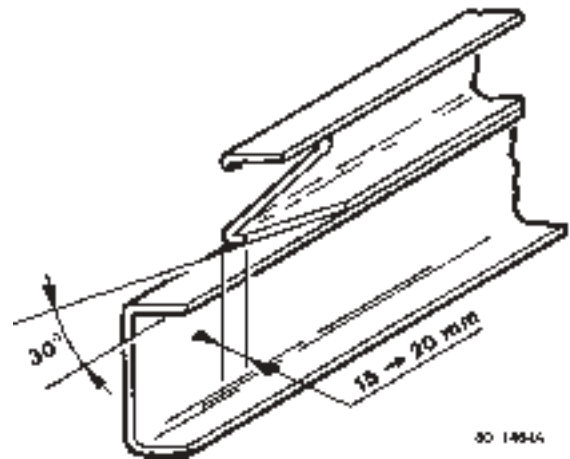
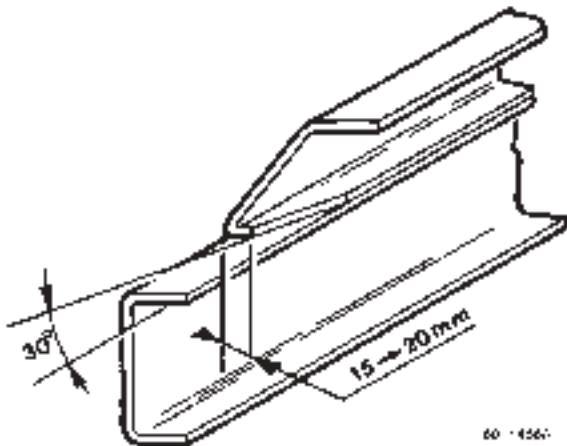

When the sub-frame is constructed of square or rectangular tube section, we also suggest the cut-out shown below.

A: Blank off with 1.5 mm thick sheet metal

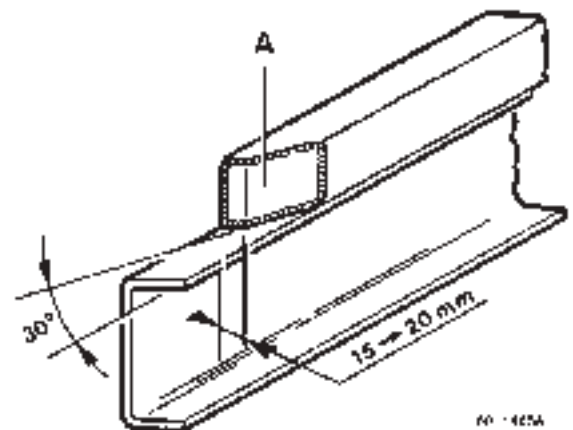

2.5 Nuts and bolts, tightening torques for parts in steel and cast iron

The torques indicated in the table are the nominal torques (i.e. average value calculated on the basis of the minimum and maximum torque).

Class III is the class covering precision tightening ($\pm 20\%$ of nominal torque) in accordance with Standard 01504002 (coefficient of friction 0.15 ± 003).

The tightening torques are given for nut and bolt hardware that is dry and coated with Dacromet.

Description	Characteristics	Class of Steel	Part Nos.	Tightening torque
Screw	H 10 x 125 L 30	10.9	50 03 101 460	60 N.m
	H 10 x 125 L 50	10.9	50 03 101 148	60 N.m
	H 12 x 125 L 40	10.9	50 03 101 151	110 N.m
	H 12 x 125 L 45	10.9	50 03 101 749	110 N.m
	H 12 x 125 L 50	10.9	77 03 101 679	110 N.m
	H 12 x 125 L 60	10.9	50 03 101 153	110 N.m
	H 14 x 150 x 40	10.9	50 03 101 161	170 N.m
	H 14 x 150 x 50	10.9	50 03 101 162	170 N.m
	H 14 x 150 x 60	10.9	50 03 101 163	170 N.m
	H 14 x 150 x 90	10.9	50 03 101 169	170 N.m
	H 14 x 150 x 100	10.9	50 03 101 660	170 N.m
	H 14 x 150 x 110	10.9	50 03 101 171	170 N.m
	H14 x 150 x 120	10.9	50 03 101 172	170 N.m
	H14 x 150 x 130	10.9	50 03 101 887	170 N.m
	H14 x 150 x 140	10.9	50 03 101 173	170 N.m
	H 16 x 150 x 50	10.9	50 03 101 103	220 N.m
Collar screw	H 10 x 125 L 30	10.9	50 03 002 048	60 N.m
	H 12 x 125 L 40	10.9	50 03 002 049	110 N.m

Description	Characteristics	Part Nos.
Cone washer	10 x 20 x 2.6	50 03 058 081
	10 x 24 x 2.8	50 03 058 071
	10 x 27 x 2.8	50 03 058 076
	12 x 30 x 3.2	50 03 058 075
	14 x 28 x 3	50 03 058 069
	16 x 32 x 3.4	50 03 058 034
	16 x 39 x 3.6	50 03 058 070
Flat washer	10 x 22 x 3	50 03 053 453
	10 x 27 x 3	50 03 053 455
	10 x 24 x 2.5	50 03 053 026
	12 x 28 x 5	50 10 054 526
	12 x 32 x 2.5	50 03 053 441
Cone washer "BELLEVILLE" type	14.5 x 35 x 1.8	50 03 053 014
		00 21 721 040

Description	Characteristics	Class of Steel	Part Nos.	Tightening torque
Nut	10 x 125	10	50 03 032 156	60 N.m
	12 x 125	10	50 03 032 157	110 N.m
	14 x 150	10	50 03 032 159	170 N.m
	16 x 150	10	50 03 032 236	220 N.m
Locknut DRH (flanged)	10 x 125	10	50 03 034 246	60 N.m
	12 x 125	10	50 03 034 248	110 N.m
	14 x 150	10	50 03 034 250	170 N.m

2.6 Addition of equipment to the bodywork

The attachment of equipment to the bodywork must be done with fluidtight crimping nuts.

Tooling and crimping nuts

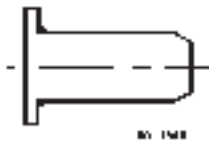
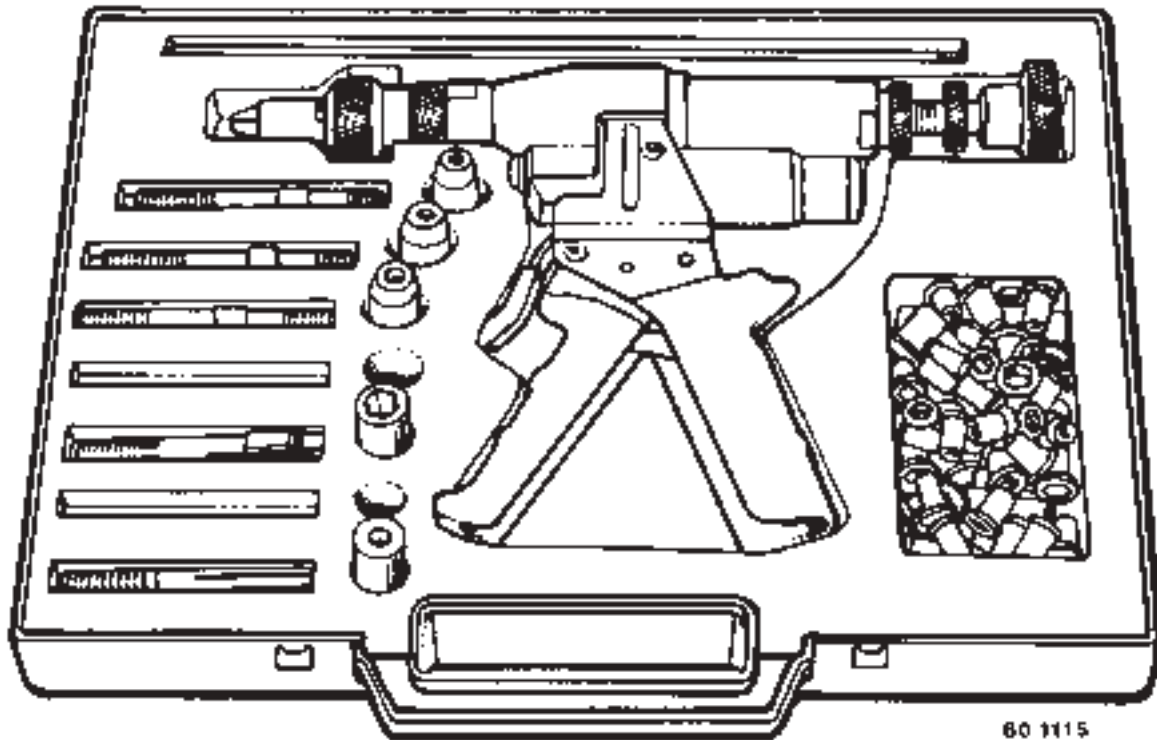

M6 crimp nut - hexagonal barrel

Part N°: 50 03 043 050

Method:

- Drill a 9.2 mm diameter hole (refer to chapter entitled "Drilling of bodywork members for the fitting of accessories").
- Use the OPEX tooling from OTALU S.A.
- Punch out the hexagonal.
- Insert the nut for crimping.

Information:

- Tightening torque max. 10 Nm.
- Length of barrel projecting under bracket after crimping: 17 mm.

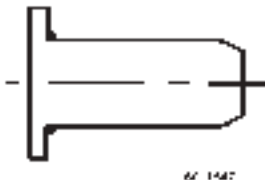

M8 crimp nut - hexagonal barrel

Part N°: 50 03 043 052

Method:

- Drill a 11.2 mm diameter hole (refer to chapter entitled "Drilling of bodywork members for the fitting of accessories").
- Use the OPEX tooling from OTALU S.A.
- Punch out the hexagonal.
- Insert the nut for crimping.

Information:

- Tightening torque max. 24 Nm.
- Length of barrel projecting under bracket after crimping: 21 mm.

2.7 Rear run-under guard

RENAULT V.I. obtains approval for its equipment to cover the requirements of its range. Their attachment being by means of bolts, this allows them to be moved down along the sidemembers to suit such modifications that the chassis may undergo. This must be observed, along with the maintenance of the attachment method detailed on the 1:20 scale bodywork drawing and compliance with the dimensional requirements under the regulations.

A vehicle which is not equipped at the time of delivery can be fitted afterwards, following a conversion making the fitting compulsory, using items which can be supplied from the Parts Stores of our dealers.

Changing of position of items of equipment

Modifications of a RENAULT V.I. vehicle for the fitting of bodywork and equipment requires technical approval to be obtained from the Product Applications Department of RENAULT V.I.

3. SPECIFIC EQUIPMENT FEATURES

3.1 Running the engine when vehicle stationary

Under the conditions of running an engine for a long period under load, it is vital to fit an additional cooler unit in order to keep the temperature of the engine at a normal level (water temperature approx. 80° C).

The prolonged use of the engine under these conditions can cause malfunctions which could adversely affect the life of the engine.

3.2 Mounting of power take-offs and flanged pumps

RENAULT V.I. power take-offs (PTOs) and their adapter kits should be ordered from the RENAULT V.I. Spare Parts Department. In order to carry out the fitting, refer to the specific information circulars that are available from the Product Applications Department.

Bearing in mind the weight and the large overhang required for certain PTOs having flanged pumps, the rear of these units should be supported by a suitable bracket attached to the rear of the gearbox.

Comply with the standard NF ISO 7653

IMPORTANT

It is compulsory at the time of fitting a power take-off to ensure that there is a certain amount of play in the setting adjustment, so as to allow an ideal backlash of 0.15 to 0.25 mm then to fit a gasket or apply paste in order to achieve a good seal and also to top-up the oil level. (Refer to the vehicle maintenance handbook). Refer to our Product Information Sheet and 1:20 scale bodywork drawing on "power take-offs", which can be requested from our Product Applications Department.

3.3 Front power take-offs (crankshaft nose)

RENAULT V.I. pre-arrangement

For belt drive units, pulleys with extra grooves fitted to the engine may be available.

Consult the Product Applications Department to obtain the relevant information and technical approval for the assembly.

3.4 Front and rear power take-offs

3.4.1 Propeller shaft alignment

In order to achieve satisfactory propeller shaft alignment, several minimum basic criteria have to be observed.

Angularity criteria (or: equivalent angle of inclination β_E permissible for all articulations).

This angle β_E must comply with the following condition:

$$\beta_E = \sqrt{|\beta_a^2 \pm \beta_b^2 \pm \beta_c^2 \pm \dots|}$$

$$\beta_E \leq 3^\circ$$

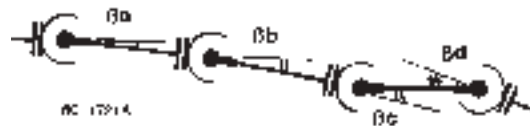

Rule for sign β :

Yoke N° 1 is to be considered as the reference yoke.

$\beta > 0$ when the leading yokes are parallel to the first leading yoke (Ma).

Example 1:

$$\beta_E = \sqrt{|\beta_a^2 + \beta_b^2 + \beta_c^2 - \beta_d^2|}$$

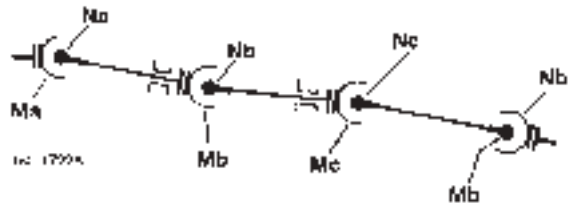

M - Leading yokes

N - Trailing yokes

$\beta < 0$ when the leading yokes are perpendicular to the first leading yoke (Ma).

Example 2:

$$\beta_E = \sqrt{|\beta_a^2 + \beta_b^2 - \beta_c^2 + \beta_d^2|}$$

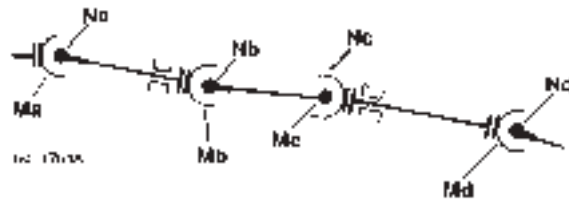

Angular acceleration criteria θ_1

Calculated criterion for a theoretical maximum speed of rotation (N).

$$\theta_1 = \left(\beta_E \times \frac{\pi}{180} \right)^2 \times \left(\frac{\pi \times N}{30} \right)^2$$

$\theta_1 \leq 270$

θ_1 : criterion of acceleration in rd/s^2
N: max. speed of rotation in rpm

NOTE

This value is calculated without dynamic amplification of the prop shaft tubes and bearings.

Measured criteria θ_2 :

The angular acceleration or torsional vibrations criteria value θ_2 must not exceed 1500 rd/s^2 at the PTO output or at any point whatsoever of the driveline for a downstream inertia of I such that $I \leq 0.2 \text{ kg/m}^2$.

$$\theta_2 \leq 1500 \frac{\text{rd}}{\text{s}^2}$$

NOTE

This limit value θ_2 takes into account possible dynamic amplification of the driveline.

Transversal stress criteria for prop shaft tubes and bearings.

Example β_1 and β_2 maximum not to be exceeded.

- $\beta_a < 2^\circ$ for a prop shaft with bearing.
- $\beta_b < 7^\circ$ for a prop shaft with sliding yoke.



NOTE

If this 7° value has to be exceeded for space or clearance reasons, the vehicle manufacturer must be consulted.

3.4.2 Propeller shaft balancing

Permissible imbalance value (B):

$$B \leq 3 \frac{g \times cm}{kg} \text{ per balancing plane}$$

- 1 - 1/2 prop shaft
- 2 - prop shaft

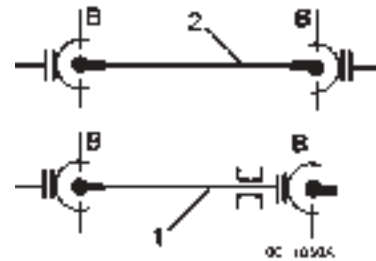

NOTE

$g = m = 10 \text{ m/s}^2$

3.4.3 Maximum permissible length of a prop shaft as a function of the rotating speed (L, L1 or L2)

- L: Distance between centres of articulation of a prop shaft.
- L2: Distance between centres of articulation welds of a half prop shaft.
- L1: Distance between centres of articulations of a half prop shaft.
- L1 = L2

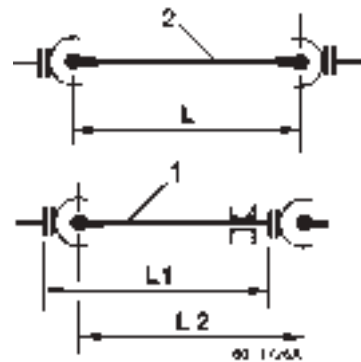

$$L = \sqrt{\frac{K}{Nt \times 1,2}} \quad \text{with} \quad K = 0,75 \times 1.22 \times 10^5 \times \sqrt{D^2 + d^2}$$

- Nt = prop shaft maximum operating speed
- 1.2 = safety coefficient
- D = prop shaft large diameter
- d = prop shaft small diameter

3.5 Vehicle driveline (powertrain)

Any modification to the driveline is forbidden. For special cases, agreement must be obtained from the RENAULT V.I. Product Applications Department.

Any propeller shaft modifications must only be carried out in conformity with the requirements of paragraphs 3.4.2 and 3.4.3.

3.6 Mounting of handling cranes

The installer of the crane is responsible with regard to compliance with the regulations, and also for the stability of the vehicle. The recommendations of RENAULT V.I. are only concerned with the attachment of the equipment.

3.6.1 Mounting on the sub-frame

The mounting of a crane on the chassis behind the cab or in the rear overhang requires the fitting of a specific sub-frame.

The sub-frame module is defined in the graph of inertia in accordance with the lifting torque only for a crane mounted behind the cab and on rigid or drawbar rigid vehicles (refer to the next page).

For all mountings of cranes in the rear overhang, off-limits and on tractors, consult the RENAULT V.I. Product Applications Department.

The sub-frame must be in one single piece, starting from the rear of the cab, and extending as far back as the rear tip of the overhang. The front end must be finished in a single or double bevel (refer to the chapter 2.4.1 entitled "Finishing of the sub-frame behind the cab").

Should the crane be mounted in conjunction with another item of mobile equipment, one single sub-frame shall be designed in accordance with that item of equipment which places the most strain on the sidemembers.

3.6.2 Graph of the moment of inertia of the sub-frame as a function of the lifting torque

Example:

A chassis with sidemembers 252 mm long, fitted with a crane having a lifting capacity of 10 tonnes per metre. The chassis requires a sub-frame built of size 160 U-section beams (— direction of reading). The U-section can be replaced by any other steel section offering equivalent total inertia.

Height of sidemember

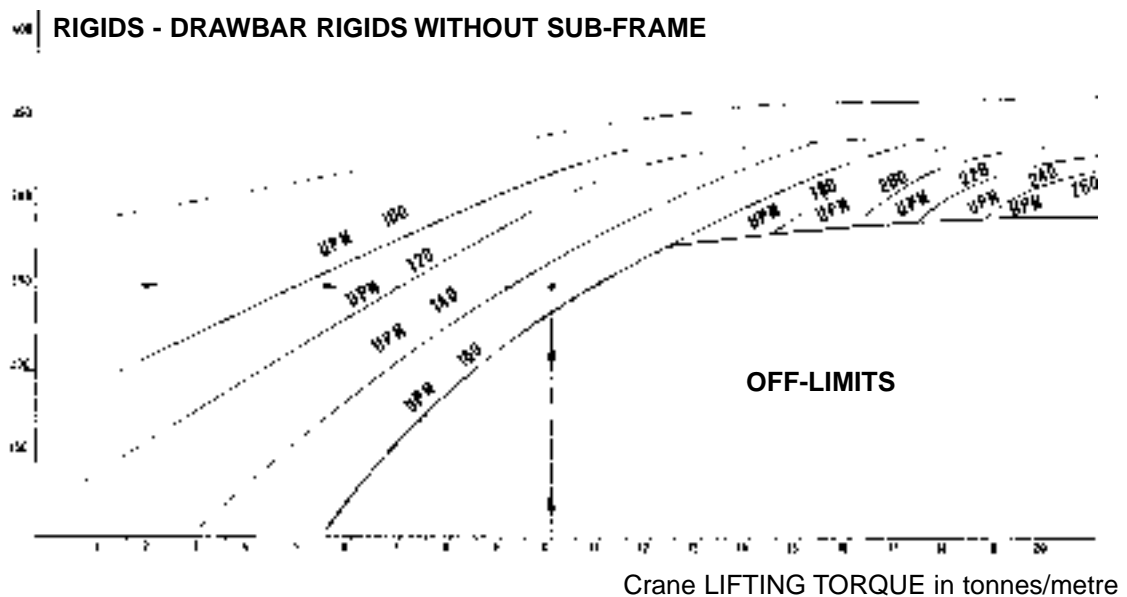

The U-section beams (UPN) can be replaced by any other steel section offering equivalent total inertia (I/V).

UPN 100 : I/V = 41200 mm ³	UPN 160 : I/V = 116000 mm ³	UPN 220 : I/V = 245000 mm ³
UPN 120 : I/V = 60700 mm ³	UPN 180 : I/V = 150000 mm ³	UPN 240 : I/V = 300000 mm ³
UPN 140 : I/V = 86400 mm ³	UPN 200 : I/V = 191000 mm ³	UPN 260 : I/V = 371000 mm ³

WARNING

Before undertaking the mounting of a crane on a vehicle, it is essential to make calculations to check the load distribution, and to determine the new maximum body length of the vehicle, whilst complying with:

- The plated gross vehicle weight (GVW).
- The maximum plated axle loads.
- The maximum rear overhang indicated in the Type Approval Department's descriptive sheet and the body-work diagram.

Should such limits be exceeded and in all cases where the work does not comply with the type approval department descriptive sheet, special authorization must be requested from the RENAULT V.I. Product Applications Department.

In addition to this, the bodybuilder will be responsible for commissioning the equipment.

3.6.3 Crane in the rear overhang (except RENAULT PREMIUM / KERAX)

The installer of the crane is responsible with regard to compliance with the regulations, and also for the stability of the vehicle. The recommendations of RENAULT V.I. are only concerned with the attachment of the equipment.

The sub-frame required for such assemblies must be diagonally braced in accordance with the diagram below, using U-section beams with a module that is immediately lower than that recommended for the sub-frames.

Example: A sub-frame made of size 140 U-section beams shall be diagonally braced with size 120 U-section beams.

For a crane mounted in the rear overhang, in addition to the recommendations contained in the "WARNING" paragraph above, the following must also be observed:

- The minimum front axle load, for a vehicle fitted with a body and equipped with crane.

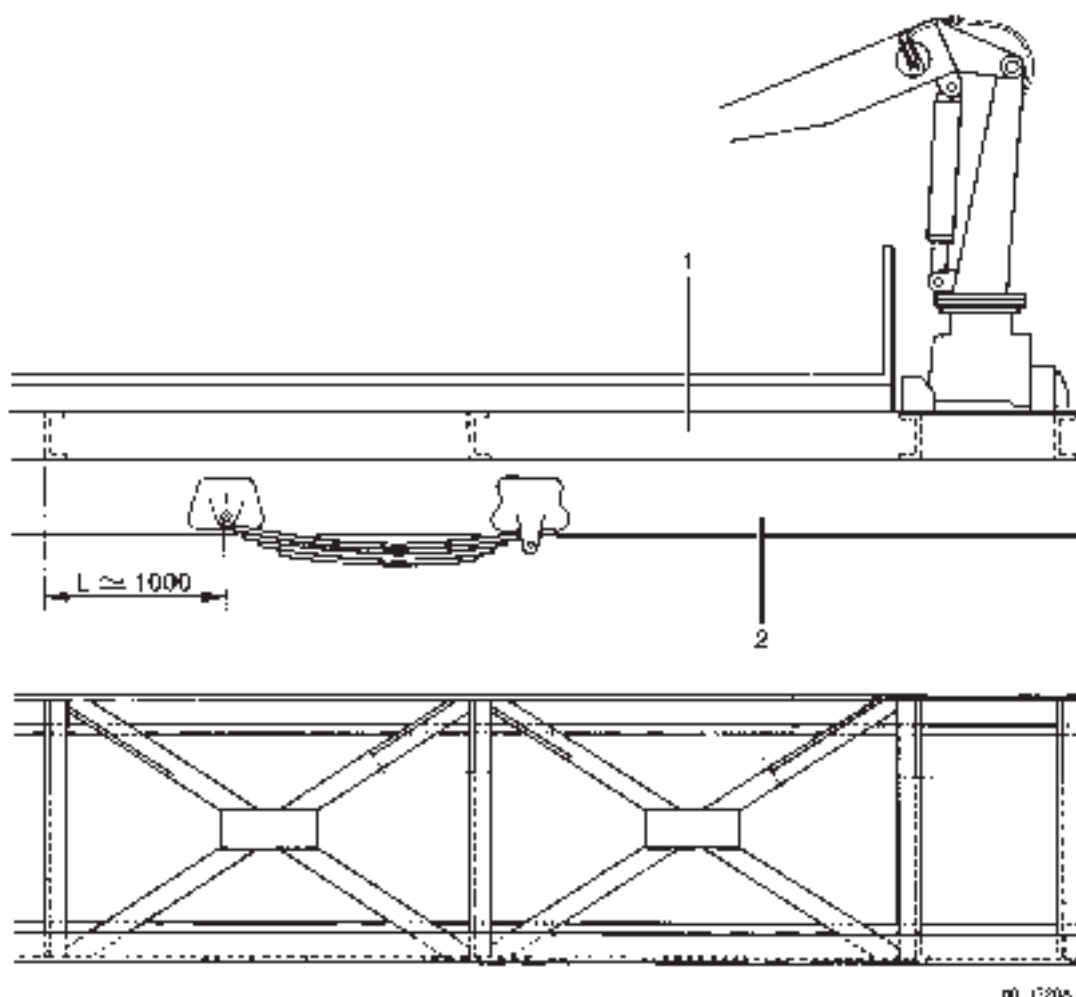

- 1 - Sub-frame
- 2 - Vehicle chassis

3.7 Tail lifts

3.7.1 Sub-frames

In the majority of cases, the mounting of a tail lift involves the fitting of a sub-frame to the vehicle. Such a sub-frame must reinforce the entire length of the chassis, with the bevelled front end being located as far forward as possible under the cab.

The module to be used for the sub-frame must be determined for tail lifts:

- without landing legs, for a capacity of 400 to 2,000 kg
- with landing legs, for a capacity of 1,000 to 2,000 kg
- by referring to the graph of inertia of the sub-frame depending on the load to be lifted, plus the information contained in the paragraph entitled "Special Recommendations", which also deals with tail lifts with a capacity of 1,500 kg without landing legs and tail lifts with a capacity of 2,000 kg with or without landing legs.

3.7.2 Attachment

The tail lift is to be fastened in position with bolted plates. In all cases, the design of the attachment should involve that of the body sub-frame as well. Nut and bolt hardware is to be of class 10.9 fine pitch with a diameter of 12 mm. The plates are to be fastened in position with at least 6 nuts and bolts on each side of the chassis and by 3 bolts and nuts or only by welding to the sub-frame.

If necessary, it may be necessary to wedge the tail lift beam or plate on the lower flange chassis sidemember, so as to avoid flexing of the sidemember.

NOTE

Do not weld the bolted plate to the chassis.

WARNING

In all cases of conversions for tail lifts, it is absolutely essential to calculate the new length of body, to ensure compliance with:

- The maximum plated gross vehicle weight (GVW).
- The maximum load on the front axle, with the vehicle fitted with its body and equipped with tail lift.
- The maximum plated loads on the front and rear axles.
- The maximum rear overhang indicated in the Type Approval Department's descriptive sheet and the body-work diagram.

If any loads are exceeded, you should consult the Product Applications Department.

3.7.3 Electrical connections for a tail lift

Electrical connections should comply with the recommendations set out in the chapters entitled "Fitting of specific equipment" and "Electrical equipment".

3.7.4 Special recommendations for tail lifts from 1500 to 2000 kg without landing legs

1,500 kg tail lift

- This is only possible using our chassis with a GVW equal to or greater than 16 tonnes.

2,000 kg tail lift

- This is only possible using our chassis with a GVW equal to or greater than 19 tonnes.
- For off-limits and for vehicles with a lower capability, consult the Product Applications Department.

Should the run-under guard have to be modified, care should be taken to ensure compliance with regulations in force.

3.7.5 Graph of the moment of inertia of the sub-frame as a function of the lifting torque

How to use the graph

- Draw a straight line joining the type of tail lift in question (lower part of the graph) to the mark corresponding with the height of the sidemember in mm.
- Draw a straight line from the value of the sidemember height.
- Read the value for the sub-frame at the intersection of these two lines.

NOTE

For the mounting of tail lifts on 6x2 vehicles, it is essential to consult the RENAULT V.I. Product Applications Department.

Example:

Take a chassis with 234 mm high sidemembers, equipped with a 750 kg tail lift.
It requires a sub-frame made of size 80 U-section beams.

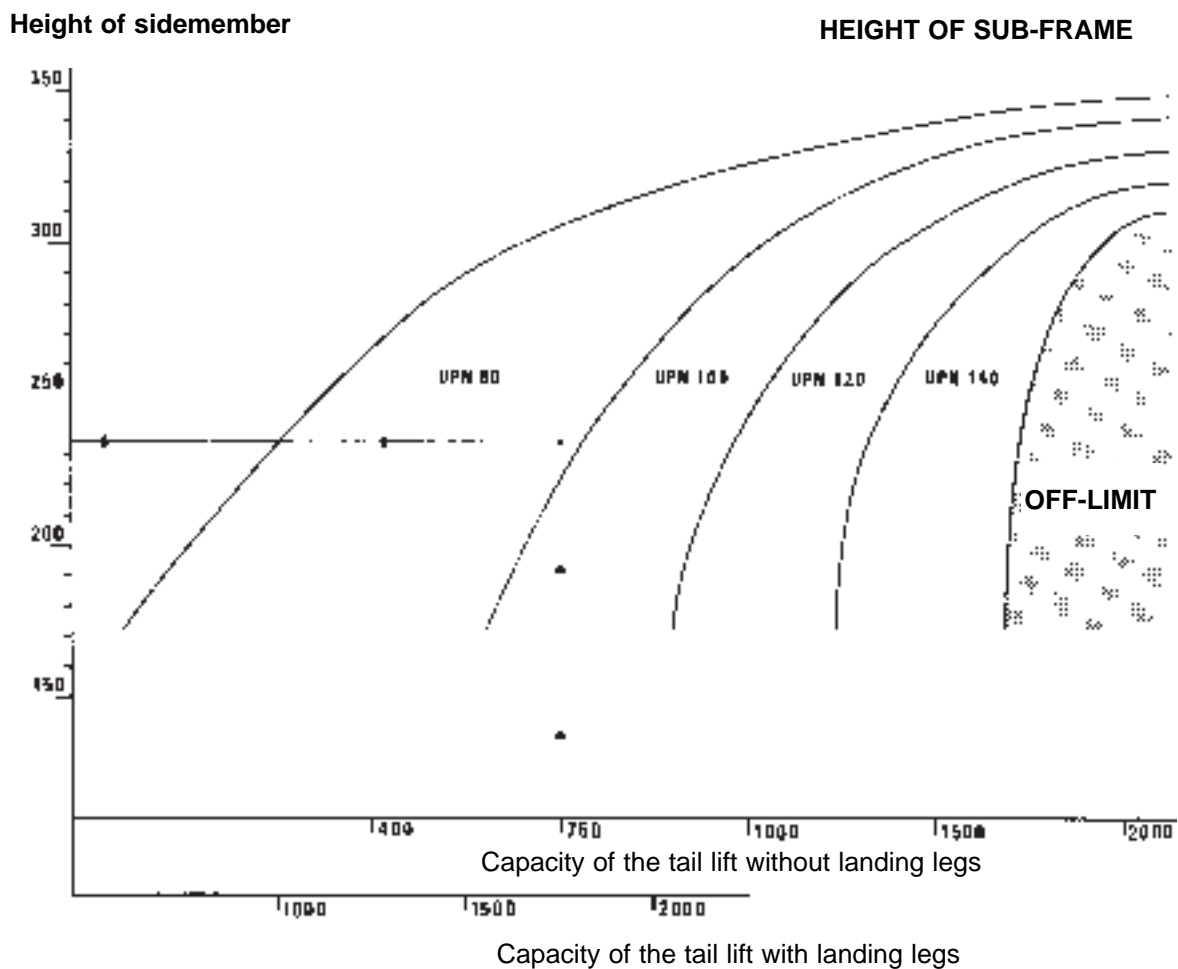

NOTE

The size 80 U-section beams can be replaced by any other section which gives an equivalent inertia (I/V).

UPN 80: $I/V = 26500 \text{ mm}^3$

UPN 120: $I/V = 60700 \text{ mm}^3$

UPN 100: $I/V = 41200 \text{ mm}^3$

UPN 140: $I/V = 86400 \text{ mm}^3$

3.8 Sub-frame box sections

The recommended box sections should:

- be constructed in sheet metal which is as thick or thicker than that used for the sub-frame.
- stretch over the entire rear of the sub-frame, starting gradually at least one metre in front of the foremost spring hanger of the rear spring.

WARNING

If the sub-frame is to be constructed in a material other than commercially available U-section beams, we approve all other sections on condition that the modulus of inertia of the "truck sidemember + sub-frame" section, measured at the centre-line of the rear axle, be at least equal to the modulus which we recommend (refer to the previous page).

It is forbidden to make any butt welds on the sub-frame in the area defined as follows:

- from the centre-line of the rear axle up to 500 mm to the aft of the rearmost spring hanger of the rear spring, in the case of 4x2 and 4x4 vehicles.
- from the centre-line of the middle axle up to 500 mm to the aft of the centre-line of the rear axle, in the case of all other vehicles.

3.9 Fitting of specific equipment (for example: refrigerator unit, tail lift)

3.9.1 Electrical connections

Refer to the recommendations for use (chapter on "Electrical equipment" in the General Section).

The power supply cable should be in one single piece, with a cross-section calculated for a max. rating of 5 Amps per mm². The power supply must be protected by a fuse and controlled by a specific master switch during fitting. It is compulsory for the cables to be connected to the battery terminals. The fuse and the master switch must be located as close to the battery connection as possible (in order to keep to a minimum the length of unprotected line).

The electric power and auxiliary wiring must compulsorily be independent from that of the vehicle network.

For this, you should contact the Product Applications Department in order to obtain its permission.

In the case of conversion of an independent self-contained unit on the front end of the body, an access ladder and platform for maintenance purposes should be provided.

3.9.2 Installation of receivers or generators with a voltage of more than 24 V

Comply with the standards in force and with the safety regulations covering installations and safety of the person (decree dated 14/11/1988). The protective earth is to be made on the equipment, and never on the vehicle structure.

3.10 Tapping on the diesel fuel tank

It is forbidden to drill the tank for the installation of a tapping point.

3.11 Hitch coupling for rigid drawbar trailers (only on RENAULT MIDLUM)

3.11.1 Fitting of an additional crossmember

If the rear crossmember fitted is too high, there is the possibility of fitting a second crossmember underneath the other.

The fitting of this must be carried-out using reinforcement plates on the side rails of the sidemembers of the chassis. The attachment bolts of the upper crossmember are used for location of the reinforcing plates. In addition, two rows of eight bolts are to be fitted to each side which are attached to the sidemembers.

The crossmember is mounted on the reinforcement plates and has the same alignment as the crossmember used on the standard vehicle. Use all the holes in the crossmember for the attachment of this. Put in a spacer on each side to take up the space between the new crossmember and the reinforcement plate.

3.11.2 Minimum thickness of reinforcing plates

Thickness = 1.2 x thickness of the sidemember.

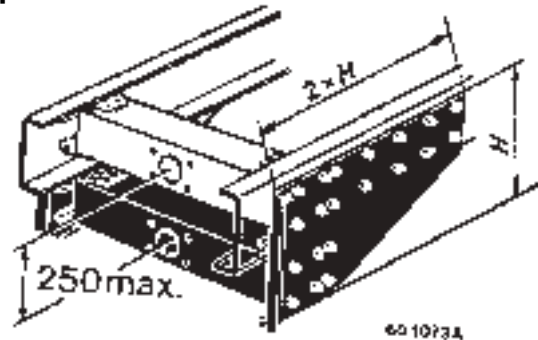

3.12 Fifth wheels (baseplates and couplings)

Tractor chassis are normally supplied as original equipment with bolted angle irons. In this case they allow for the longitudinal positioning of the baseplate for the fifth wheel on the chassis, in order to ensure good load distribution on the tractor axles.

The fifth wheel is located on these angle-irons by the use of a crossmember and/or a baseplate (in certain cases the baseplate is sufficient).

The fitting of the fifth wheel must allow for the manoeuvring of a swan-necked semi-trailer in accordance with the ISO Standard in force.

The bedplate and the baseplate must be independently mounted, with a minimum strength equal to that of the attachment for the fifth wheel.

Baseplates for each type of vehicle are available in several heights from the Spare Parts Department.

Refer to the Product Applications Department.

3.12.1 Mounting standards

Comply with the standard in force.

Kingpin 50 mm (2") dia.

The attachment of the fifth wheel to the chassis must be done using 12 bolts size M16, quality class 10.9.

Kingpin 90 mm (3.5") dia.

For details of the attachment of the fifth wheel, refer to the Product Applications Department or comply with the recommendations of the supplier.

These values apply equally for the attachment of the baseplate.

As far as swan-necked semi-trailers are concerned, which are not constructed in accordance with the ISO Standard in force, the attachment of the fifth wheel must take into account the instructions given above, whilst conforming with the capability of the tractor to manoeuvre, i.e. it must not come into contact with parts of the chassis, such as mudguards, rear lamps, registration plates, the back end of the chassis, the tyres, etc.

If the changing of position of the fifth wheel towards the front causes any interference of the mounts of the baseplate with those of a crossmember, you are obliged to refer to the Product Applications Department.

Drawing for drilling the baseplate for the attachment of the fifth wheel using 12 bolts \varnothing 16 mm (DIN Standard 74081)

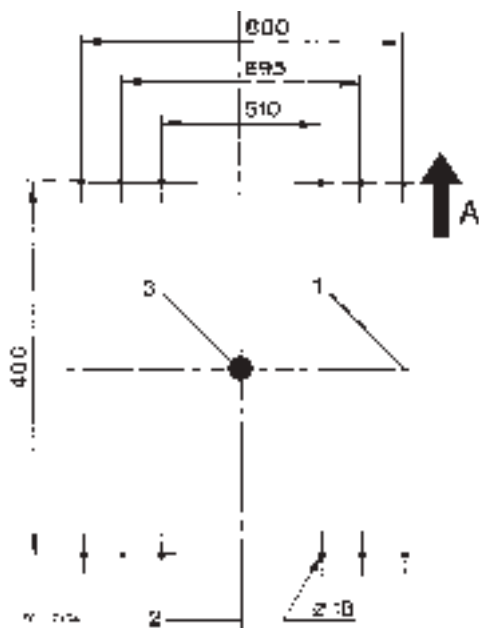

Drawing for drilling the baseplate for the attachment of the fifth wheel by 12 bolts \varnothing 16 mm with slotted holes (Standard NF R 41-171 dated October 1986)

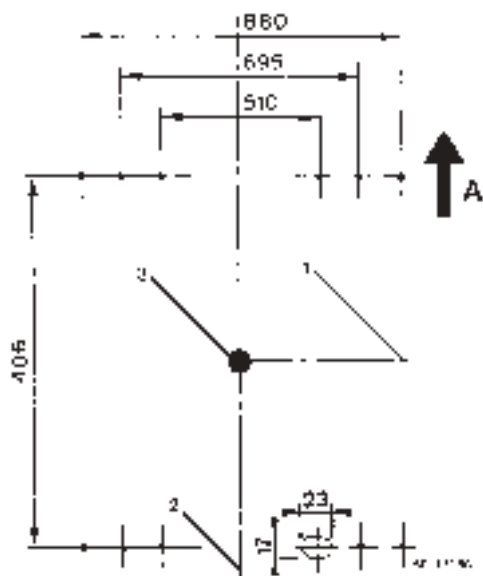

- A - Direction of movement of vehicle
- 1 - Lateral axis
- 2 - Longitudinal axis of the tractor engine
- 3 - Kingpin axis

**CHAPTER -B-
“RENAULT PREMIUM” SPECIAL
BODYBUILDING FEATURES**

1. PRESENTING THE “RENAULT PREMIUM” SERIES

This new series consists of two families of vehicles that have been fully adapted for their intended use.

The DISTRIBUTION concept for short and medium distances.

Its main attributes are:

- a choice of 5 power units (220, 270, 320, 370, 420 hp),
- 2 stairwell steps giving access to the very low cab floor,
- VISION type passenger's door,
- versions designed specially for certain applications: tanker, large volume, car transporter, refuse collector.

The LONG DISTANCE concept for medium and long haul.

Its main attributes are:

- 3 power units (320, 370, 420 hp),
- a high driving position with 3 access steps,
- 4-point cab air suspension,
- day, sleeper or raised cabs,
 - optimization of chassis weight (dead weight).

During the development of this series, **RENAULT V.I.** naturally placed the emphasis on bodybuilding ability.

The main trends are expressed directly by:

- a choice of 9 wheelbases for 4x2, rigids, 8 wheelbases for 6x2 rigids and 4 wheelbases for 6x2/4 rigids giving full coverage of all body lengths,
- no equipment protruding above the chassis,
- 2 sidemember module heights: one low sidemember for optimizing the effective loading height and one sidemember 32 mm higher offering higher technical loading capacities,
- grouping together and standardization of locations for battery compartment, fuel tank, air tanks...,
- pre-drillings with a constant pitch for the attachment of equipment,
- brackets distributed over the length of the sidemember,
- electrical and pneumatic pre-arrangements.

1.1 Changes to “RENAULT PREMIUM”

- engines equipped with common rail fuel-injection and electronic management offering new power ratings:
- discontinuation of soundproofing screens behind cab and on gearbox,
- new instrument panel and new display (with new functions).

1.2 Make-up of the series

RENAULT PREMIUM 4x2 rigid 18/19 tonnes:

- 9 wheelbases (3815, 4090, 4365, 4750, 5190, 5575, 5960, 6400, 6785 mm)

RENAULT PREMIUM 6x2 rigid:

- 8 wheelbases (3815, 4090, 4365, 4750, 5190, 5575, 5960, 6400 mm)

RENAULT PREMIUM 6x2/4 rigid:

- 4 wheelbases (4475, 4805, 5245, 5740 mm)

Depending on your vehicle's equipment

Engine:	DCI 6 AC J01 and DCI 6 W J01 - cubic capacity 6,177 cc - 2 power levels (220, 270 hp) DCI 11C+ J01, DCI 11E+ J01 and DCI 11 G+ J01 - cubic capacity 11,116 cc - 3 power levels (320, 370, 420 hp)
Engine rear PTO:	PAM 0631 PAM 0632 PAM 1131 PAM 1132
Clutch:	MFZ 430 MFZ 2.400 430 DTE 362 DBE 395 DBE
Gearbox:	Allison MD 3060 (see NC 3/3773) EATON 5206 and 8309 ZF 8S 151 ZF 9S 109 ZF 16S 109 ZF 16S 151 ZF 16S 181 ZF 12AS 2301 DD
Power take-off:	NH.1B/C NH.4B/C NL.4C N221-10.B/C 2264 2266 AS 10 B HYDROCAR 17 AX (see NC 3/3773)
Propeller shafts:	Tubular shafts with universal joints
Front axle:	E81 E82 E86 (2.36 m overall)
Rear axle:	E81
Rear drive axle:	P 1340 P 1341 P 1342 P 1345 P 1370

With inter-wheel differential lock.

Lift-up axle:	ER 8 ER 11 HENDRICKSON	
Self-tracking lift-up axle:	AUSTERAS	
Steering:	ZF 8098 with incorporated hydraulic power assistance	
Front suspension:	Leaf springs Air springs Hydraulic shock absorbers and anti-roll bars	
Rear suspension:	Leaf springs Air springs Hydraulic shock absorbers and anti-roll bars	
Brakes:	Air	
Retarders:	Exhaust brake Electric retarder Jake engine-brake ZF hydrodynamic "INTARDER"	
Electrics:	24 Volts current	
	2 batteries	140/170/190/230 Ah
	Alternator	VALEO SG 10 B 60 A VALEO SG 12 B 80 A
	Starter	MITSUBISHI 24V 5.5 kW BOSCH 24V 4 kW

1.3 Electronic management of “RENAULT PREMIUM” vehicles

1.3.1 Operating principle

Engine electronic management is used to improve engine performance while optimizing fuel consumption and pollutant emissions (in order to meet Euro 3 standard).

The electronic system consists of two principal electronic control units:

- the **EECU** (Engine Electronic Control Unit):

This is located near the battery compartment for the DCI 6 and on the engine for the DCI 11 and manages, among other things, the fuel pump solenoid valves, the FOWA exhaust brake... on the basis of information it receives from the different engine, speed, air temperature, fuel pressure... sensors.

- the **VECU** (Vehicle Electronic Control Unit):

This is located on the dashboard at the side of the connection unit and manages operation of the different vehicle equipment items (windscreen wash/wipe...), controls (accelerator, parking brake, electric retarder...), together with “bodybuilder” functions (PTO, related engine speeds...).

An instrument panel display (AFFI 2000) makes the interface between vehicle and driver. Not only classic information such as distance travelled, average or instant fuel consumption... is displayed, but also information on the state of the vehicle or its body (tailgate incorrectly closed, van lighting in service...) coupled in case of danger with the STOP warning light or a buzzer.

All these modules are interlinked by a digital communication bus (CAN bus) that allows them to exchange the necessary orders and information.

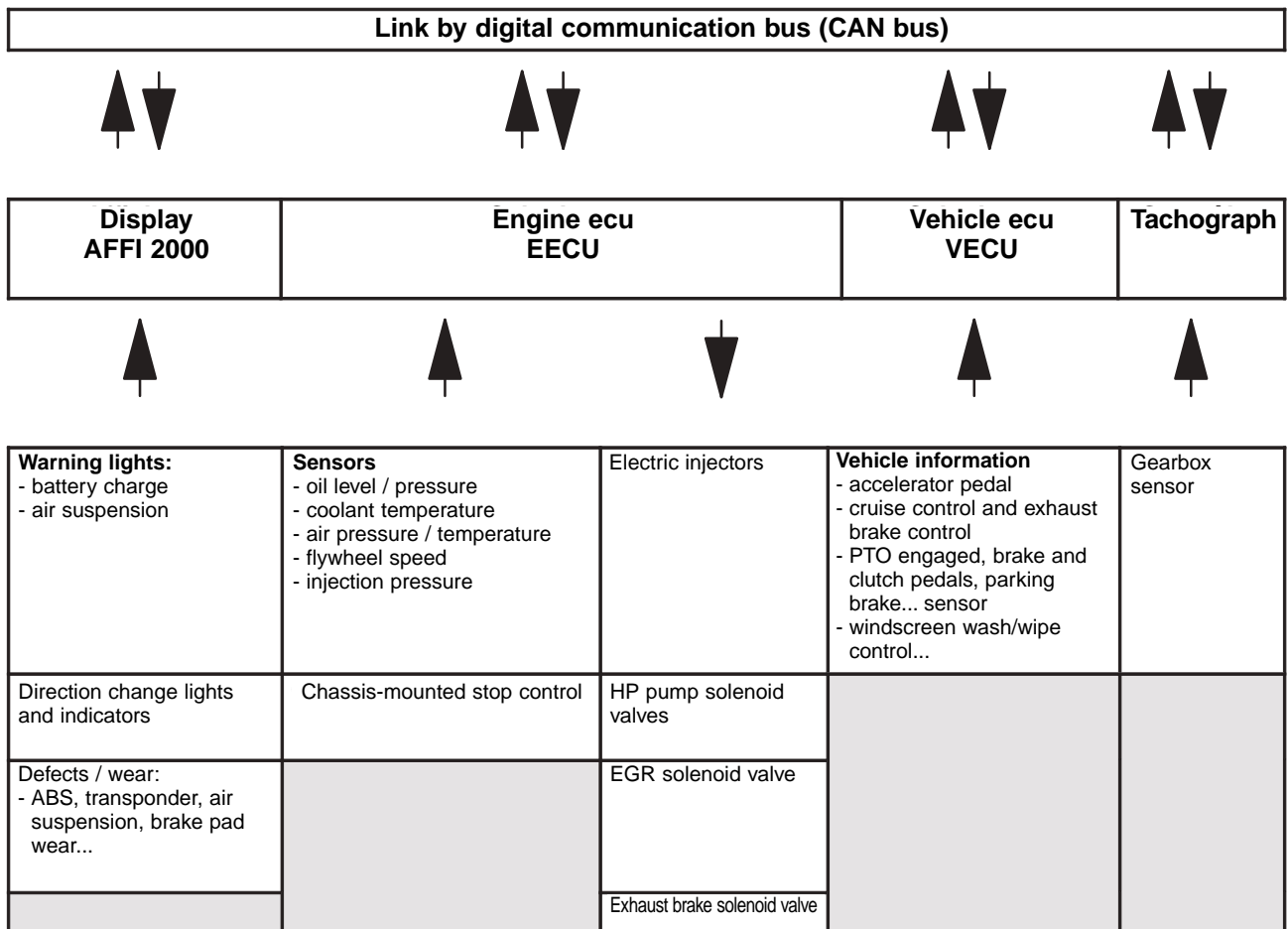

It is forbidden to cut the engine ECU wiring harness located in the battery compartment (for extension or shortening purposes).

Any changing in position must be done in an area permitted by range of movement of the wiring harness - take care to protect the ECU against splash and spray.

1.3.2 Bodybuilders' electrical pre-arrangements

The vehicle electrics is managed by the vehicle electronic control unit (VECU).

For a detailed description of the electrical pre-arrangements, see the "Electrical pre-arrangements" chapter.

1.4 Warning



Any work on the fuel system is forbidden.

On engines equipped with common rail fuel-injection operating at very high pressure, the presence of air may lead to damage to the pump.

Observe the rules governing common rail system cleanliness and bleeding, that is to be performed whenever any work is carried out on the system.

For further information, consult the RENAULT V.I. Product Applications Department.

On the low pressure circuit, changing of position of a fuel tank, adding unions or components, risks creating extra head losses:

- The specification risks not being met both at supply pump inlet and at pump return.
- The pressure regulation device risks malfunctioning (the system is sensitive to head losses).
- Check the air take-offs, make sure the fuel level is correct even when the vehicle is on an incline and during the brake application phases (difficulty in starting or stalling of the engine).
- The fuel filters must still be the last part before the HP pump inlet.
- The position of the prefilter must still be the same on the hydraulic circuit (between the injector return and the feed pump inlet).



On account of the use of electronic boxes, the installation of equipment may cause electromagnetic disturbance and oblige bodybuilders to proceed with new approval of the vehicle in respect of Electromagnetic Compatibility.



The management of engine speeds in PTO mode is managed by the electronics.

For trade vehicles, the subsequent installation of electrical pre-arrangements requires significant and complex intervention work (installation of cab and chassis wiring harnesses, re-definition of vehicle and engine ECU parameters...).



It is forbidden to walk on or place heavy articles on the engine for risk of damaging the HP injector pipes and the plastic rocker covers.



Guarantee access to the air intake, exhaust and fuel supply circuits.

The radiator inlet and outlet surfaces must not be modified.

The cooling flows must be conserved.

2. GENERAL REMARKS ON THE “RENAULT PREMIUM” SERIES

2.1 Identification of the vehicle

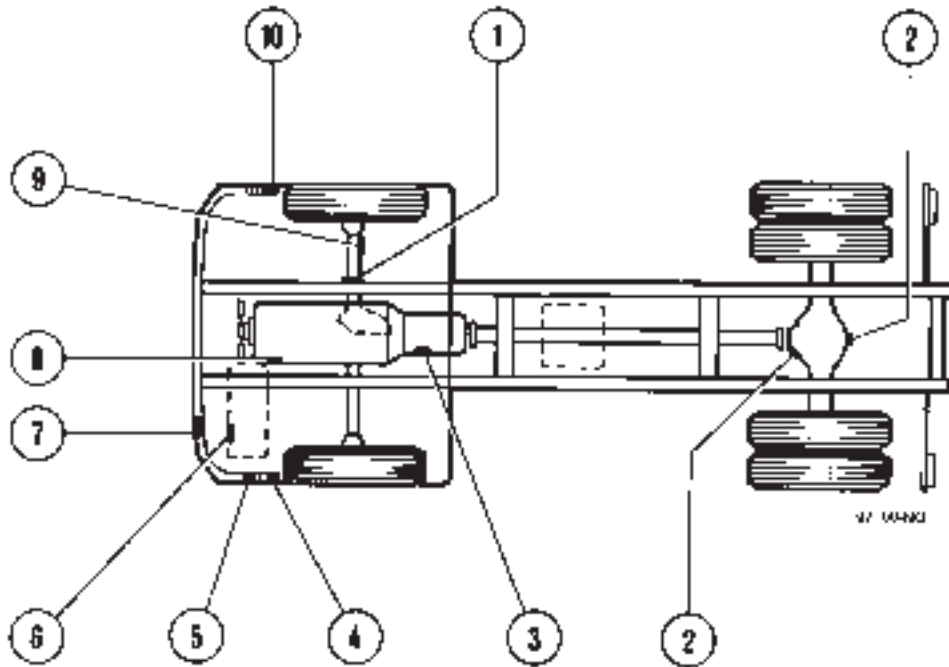

View from above

Depending on your vehicle's equipment

- 1 - Chassis
- 2 - Rear drive axle
- 3 - Gearbox
- 4 - Pollution index
- 5 - Manufacturing plate
- 6 - Tachograph plate
- 7 - CAM reference
- 7 - Paint reference
- 8 - Engine
- 9 - Axle
- 10 - Load sensing valve plate

IMPORTANT

The identification markings must remain visible and accessible without need for removing any bodywork component.

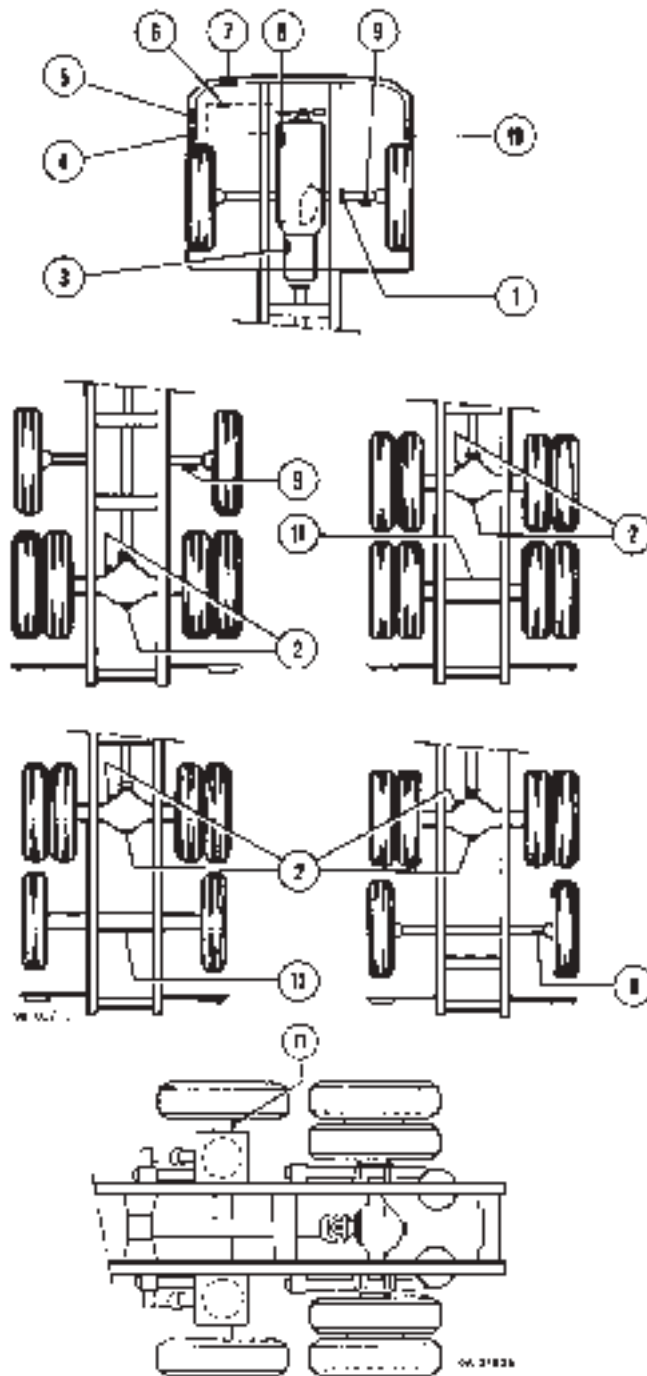

View from above

Depending on your vehicle's equipment

- 1 - Chassis
- 2 - Rear drive axle
- 3 - Gearbox
- 4 - Manufacturer's plate
- 4 - Pollution index
- 5 - Manufacturing plate
- 6 - Tachograph plate
- 7 - CAM reference
- 8 - Engine
- 8 - Paint reference
- 9 - Axle
- 10 - Load sensing valve plate
- 11 - Lift-up axle

2.2 General drilling principles

2.2.1 Drilling cab panels for fitting accessories

This allows access to sealed crimping nuts for the assembly of accessories.

The recommendations below will help avoid damage to the roof headlining at the time of drilling.

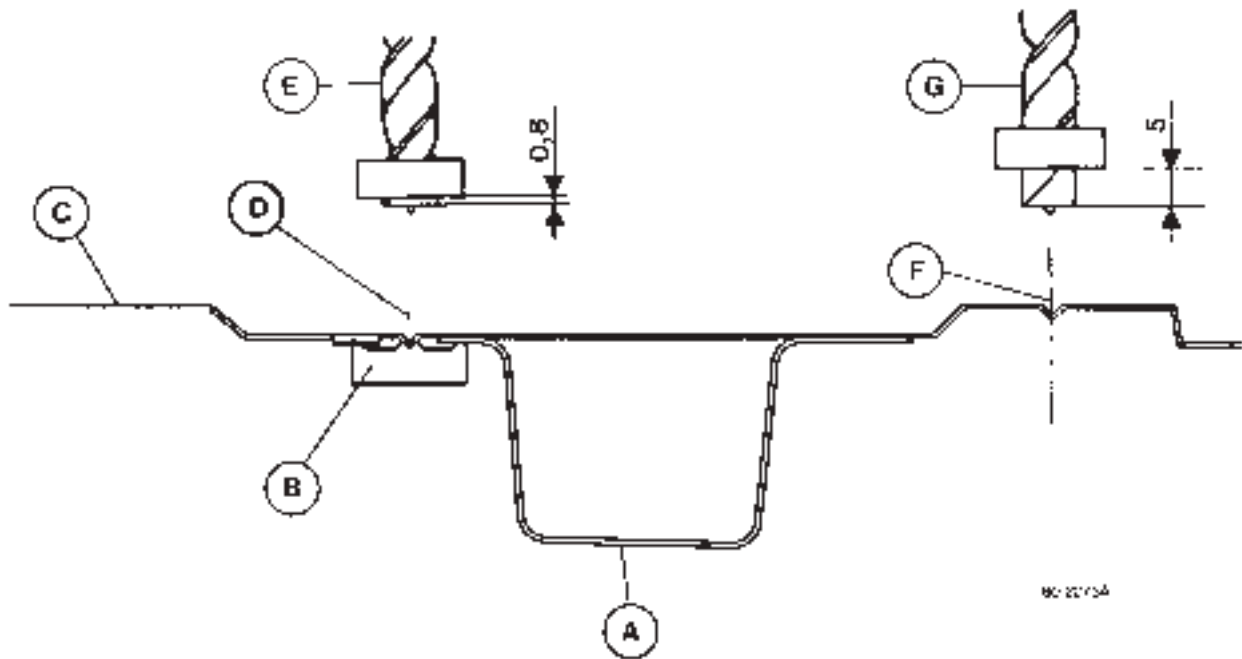

- A - Roof stiffener
- B - Weld nut on stiffener
- C - Bodywork panel
- D - Positions of impressions for drilling and access to weld nut
- E - Centring drill with stop: $\text{Ø } 10 \text{ mm}$
- F - Positions of impressions for drilling and access to crimping nut
- G - Centring drill with stop:
 - $\text{Ø } 9.2 \text{ mm}$ for crimping nut $\text{Ø } 6 \text{ mm}$
 - $\text{Ø } 11.2 \text{ mm}$ for crimping nut $\text{Ø } 8 \text{ mm}$

Details on crimping nuts and tools: see chapter "Addition of equipment to bodywork".

Method

Use a centring drill with stop positioned on the bit to drill the roof.

Drilling depth: 0.8 mm max. for fastening the weld nut

5 mm max. for fastening the crimping nut

Anti-corrosion protection:

Deburr the holes after drilling.

Protect the metal with a zinc aerosol spray available from the Spare Parts department, ref. N° 77.01.406.425.

2.2.2 Drilling in sidemembers



- No drilling in the flanges of sidemembers.
- No drilling more than 3 holes on the same vertical.

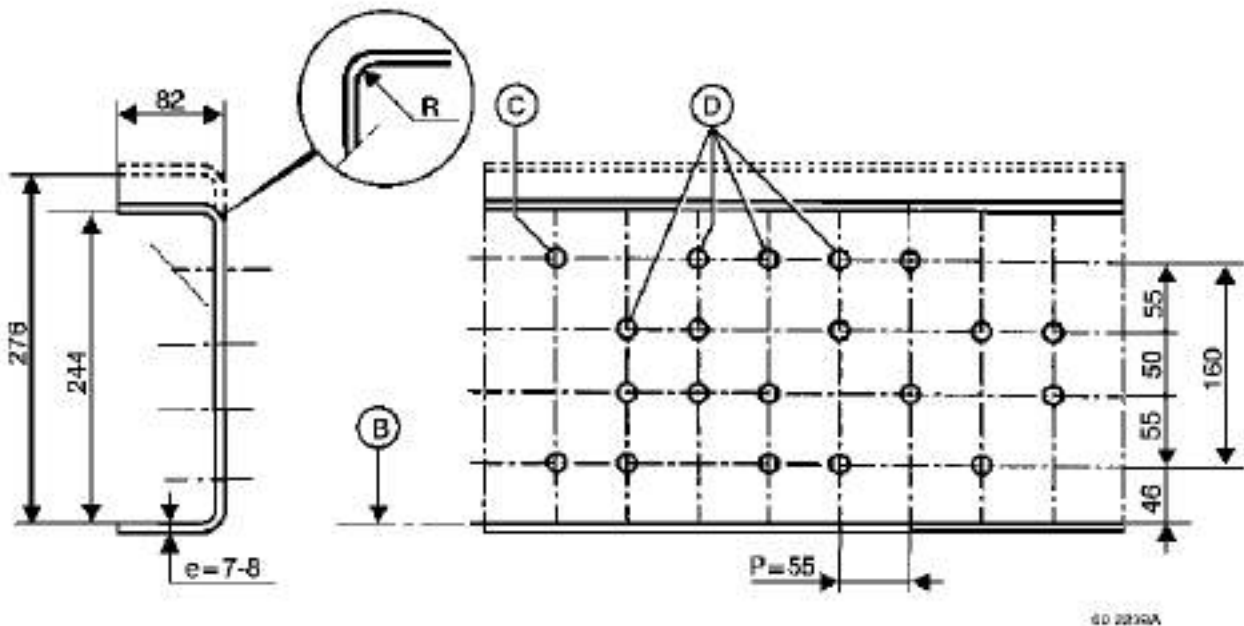

e - Sidemember thickness

P - Between-centres distance between two drillings

R - Sidemember internal radius of curvature of sidemember

C - Max. authorized drilling diameter:

13 mm for 12 mm screws

15 mm for a14 mm screws

D - Alignment of 3 holes maximum on the same vertical axis

Anti-corrosion protection and paint retouches to the chassis

Protect the metal with a zinc aerosol spray, ref. N° 77.01.406.425.

Retouch paintwork with a grey chassis aerosol paint spray, ref. N° 50.01.848.147.

These consumables are available from the RENAULT V.I. Spare Parts department.

Car transporter

Consult the RENAULT V.I. Product Applications Department to procure the drilling drawing N° 50 10 334 439.

2.3 Precautions prior to welding

2.3.1 Protection of wiring harnesses



When welding or using a disk sander, take care to protect electrical wiring harnesses and air pipe bundles against any spatter that might damage them.

2.3.2 Welding on vehicles equipped with an electromagnetic master switch



Important operations to be carried out without fail, prior to welding.

The vehicle is equipped with numerous electrical circuits. Before any operation involving electric arc welding, disconnect the positive (+) cable from the battery and connect it to earth.

Place the earthing clamp as near as possible to the point of welding, but never on rotating parts (prop shaft, fan hub, etc.) nor on a sub-assembly having moving parts (i.e. air compressor, turbocharger, etc.)

Nearby plastic pipes and electrical cables, springs and air-suspension bags are to be protected or removed. This also applies when grinding or drilling.

Diagram A: Vehicle without master switch

Diagram B: Vehicle with mechanical master switch

The master switch must be closed.

Diagram C: Vehicle with electrical master switch

Disconnect the 2 cables and join them together.

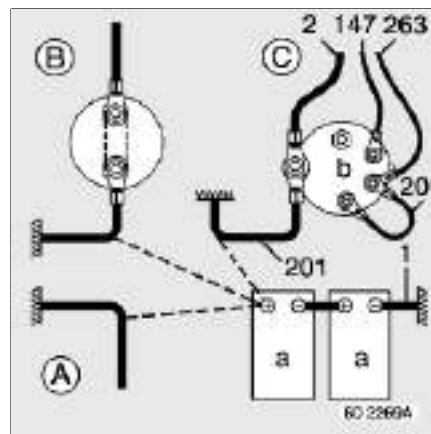

A - Batteries

B - Electromagnetic master switch

Cable 2 and 201: power part of electromagnetic master switch

Cable 147 and 263: control part of electromagnetic master switch

Marking of cables:

1 - battery earth

2 - after master switch positive (+) power supply

147 - to engine immobilizer (master switch control)

201 - before master switch positive (+) power supply

263 - to remote control box

After welding, reconnect all the cables finishing with the earth cable (1).

Other precautions before welding: refer to chapter "Precautions before welding" in the "General Features" section.



When welding in the RENAULT PREMIUM cab, place the earthing clamp as close as possible to the point of welding.

2.4 Minimum load on front axle

In order to guarantee suitable vehicle ride behaviour, stability and handling under maximum safety conditions, the minimum load on the front axle must be applied whatever the vehicle load and equipment conditions.

For special cases, consult the RENAULT V.I. Product Applications Department.

IMPORTANT

- *Never exceed the maximum permissible load on the front axle.*
- *Application of the load in the rear overhang of the vehicle is detrimental to vehicle ride behaviour, stability and handling. Great prudence is recommended when driving under such conditions.*
- *Watch that the centre of gravity of the load is positioned laterally as close as possible to the centre of the vehicle.*

2.5 Soundproofing screens and heat shields

2.5.1 Instructions for soundproofing screens

Soundproofing screens should neither be removed, modified nor displaced so as not to downgrade the vehicle sound level, which is covered by official homologation.

If it is unavoidable for them to have to be removed, they must without fail be put back into place when the work is completed.

After removal, only perfectly clean screens should be refitted.

The screens are to be cleaned using a cloth. If necessary, use soapy water (all other products are to be forbidden).

Any damage to the internal protective film of the screen requires the screen to be replaced.

In the event of on-vehicle welding or the use of a sand disk, provide efficient protection to the screens.

If the screens have been removed, provide efficient protection to the wiring harnesses.

Pay particular attention that there are no inflammable products present on the screen protective films.

Overtightening of screen attaching nuts and bolts may lead to damage.

Observe the recommended tightening torques without fail.

- screen bracket / chassis fastenings: 20 Nm \pm 20%
- screen / chassis bracket fastenings: 8 Nm \pm 20%

2.5.2 Instructions for heat shields

It is forbidden to remove or modify these shields. They play a part in the safety of your vehicle.

During chassis painting operations, take care to efficiently protect the hot face of heat shields against splashing paint and especially the shields surrounding the electric retarder. In effect, these shields are only effective if the surfaces are free from any foreign matter.

2.6 Side impact beams

Side impact beams must comply with the laws in force and should not impede access to chassis components (spare wheel, air and fuel tanks, air dryer...).

3. INSTALLATION OF BODYWORK

3.1 Use of 1/20th scale drawings and calculation sheets

Technical data sheets are tools used by sales engineers to present the range or series. They cannot be representative of particular vehicles.

To obtain precise information, refer to the 1/20th scale drawings, calculation sheets or type approval department reports to be found in the RENAULT PREMIUM CD-ROM.

Only these documents will give you accurate and reliable information on vehicles according to tonnage, air intake, cab type, weights...

3.2 Example of a search

Valid to date - If the RENAULT PREMIUM CD-ROM is modified, consult the RENAULT V.I. Product Applications Department.

- 1 - Click on the chosen language.
- 2 - Click on “**1/20th scale bodybuilder’s drawings**”.
- 3 - Click on “**Chassis cab drawings**”.
- 4 - Choose the vehicle model.

Rigids							
Normal width						Width 2360	
Normal use	RH drive	RCV	Car transporter	Towing cross-member under chassis	Fire tender	Normal use	RCV
4x2	4x2	4x2	4x2	4x2	4x2	4x2	4x2
6x2		6x2		6x2			
6x2/4		6x2/4					
6x2 Rear steer							

- 5 - Choose the drawing N° according to wheelbase and engine power rating (click on “**5010349762**”).

	RH drive
	4x2
Wheelbase	210–250 ch
3815	5010349761
4090	5010349762
4365	5010349763
4750	5010349764

6 - Click on “**Visualize PDF format**”.

Drawing N° 5010349762
Visualization of PDF format
Recording of DXF format
Access to grids

7 - Visualize the drawing and print out.

On the calculation sheet table (**A**), choose the grid N° to consult according to engine power rating, suspension and grid N° to consult (e.g. 5010367319B).

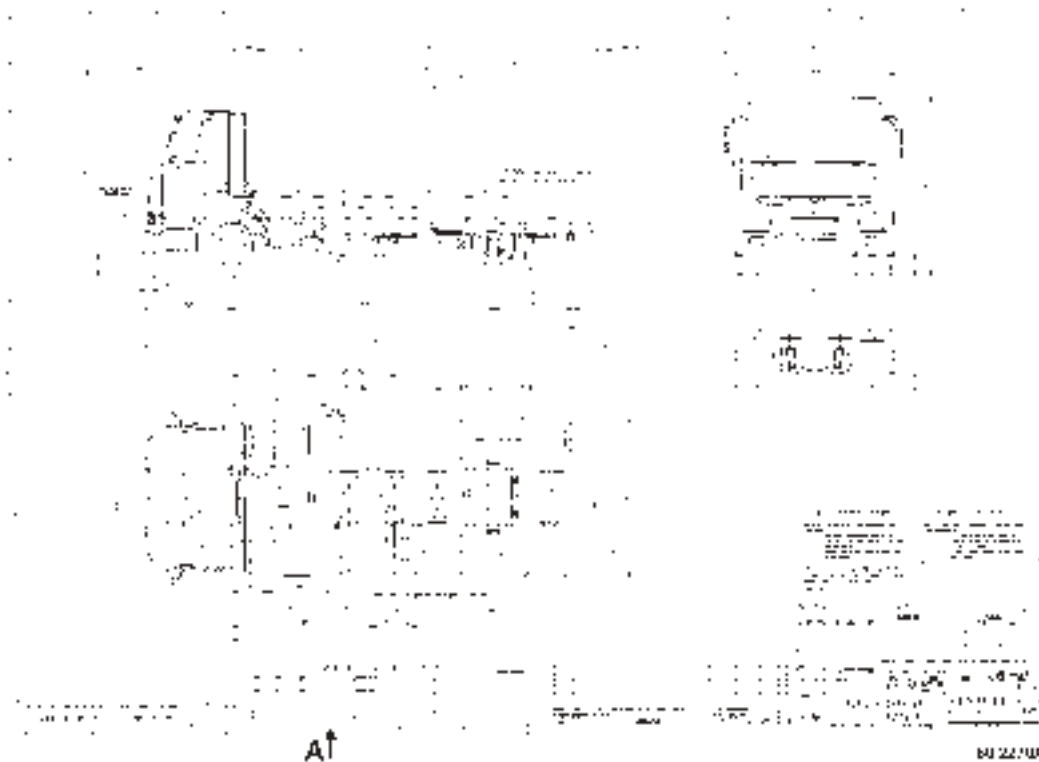

8 - Go back to the last screen.

9 - Click on “**Access to grids**”.

Drawing N° 5010349762
Visualization of PDF format
Recording of DXF format
Access to grids

10 - Write down the grid N° “5010367319”, click on “Find”.

Grid N° **5010367319**
Find

11 - Click on “Visualization of PDF format”.

Grid N° 5010367319
Visualization of PDF format

12 - Visualize the grid and print out.

- A - Calculation grid number
- B - Vehicle identification
- C - Vehicle make-up
- D - 1/20th scale drawings number
- E - Wheelbase
- F - Body entrance dimension
- G - Height



See without fail;

- cab accompanying drawings (overall dimensions, tilting radius...)
- chassis accompanying drawings (position of appliances...).

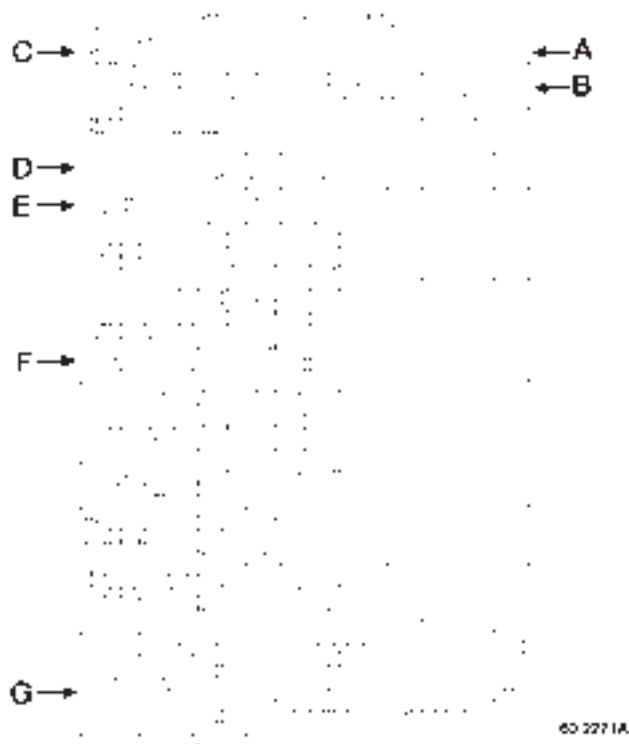

3.3 Body entrance dimension

3.3.1 Behind-cab surrounds

To prevent the components forming the rear surrounds of the cab from entering into contact with the bodywork, a minimum body entrance dimension, depending on the height of the sub-frame employed, is to be observed.

The components forming the rear surrounds of the cab are:

- direction change indicator lamps,
- cab rear fireproof screen for ADR vehicles,
- front wings and brackets.

Day cab

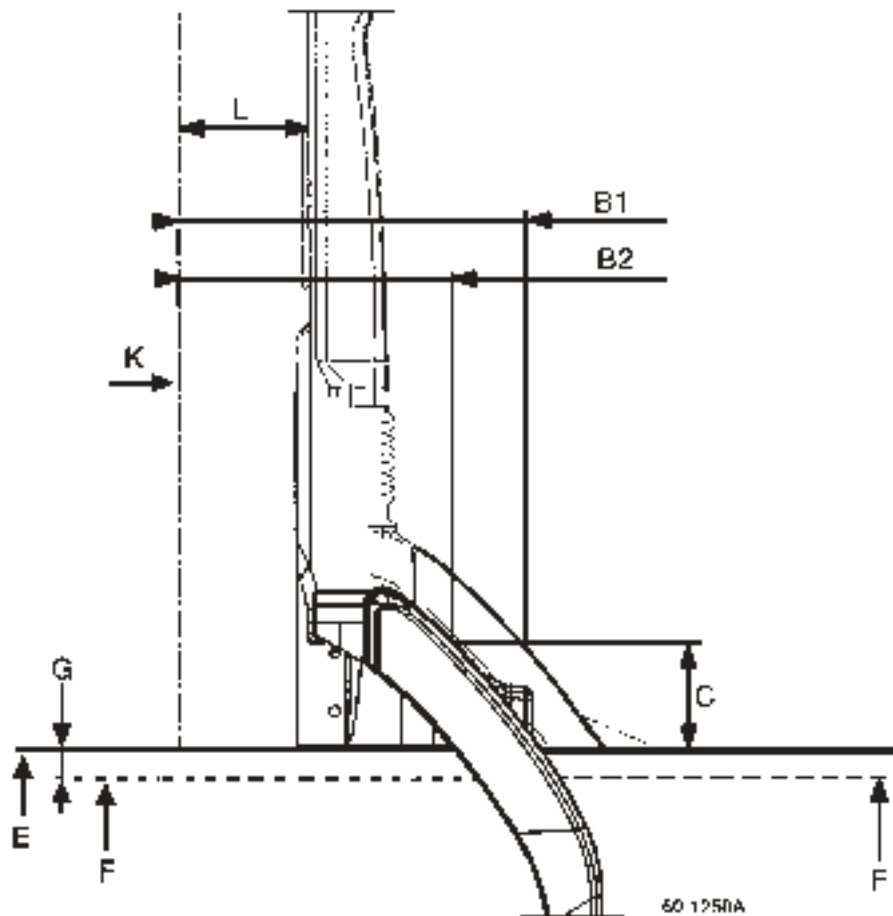

B1 - Body entrance dimension with roof air intake

- 525 mm if F = 258 mm
- 490 mm if E = 290 mm

B2 - Body entrance dimension with low air intake

- 435 mm if F = 258 mm
- 400 mm if E = 290 mm
- 465 mm (with Intarder)

C - Sub-frame height = 180 mm

E - Sidemember height = 290 mm

E - Sidemember height = 258 mm

G - Sidemember height difference = 32 mm

M - Axle centre-line

L - Cab back = 205 mm

Large volume vehicle

Improved body entrance dimension with:

- 220/270 hp power unit (6 litres)

- low air intake

- tyres 305/70 R22.5 and 315/60 R22.5

B2 - Body entrance dimension with low air intake = 290 mm

C - Sub-frame height = 180 mm

F - Sidemember height = 258 mm

K - Axle centre-line

L - Cab back = 205 mm

P - Rounded corner height after cut-out = 638 mm

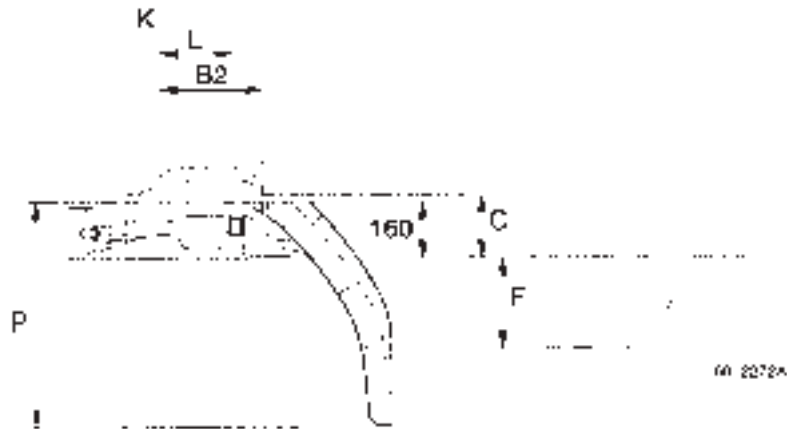

Sleeper cab

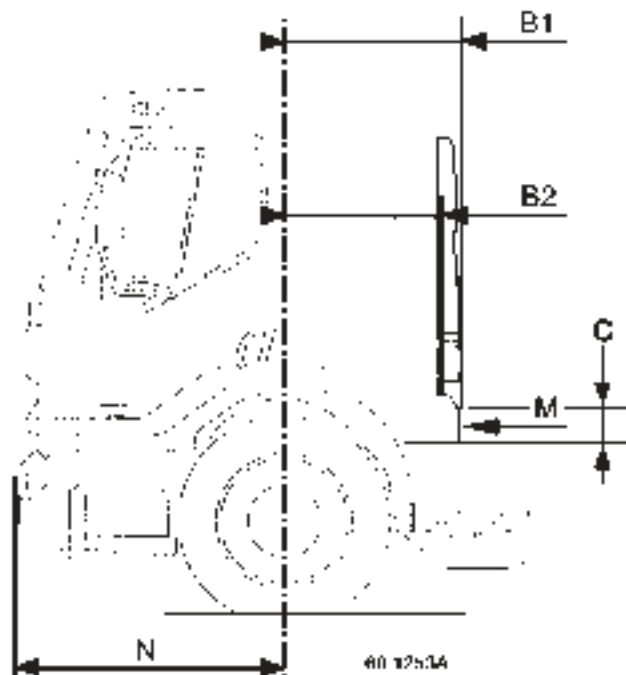

B1 - Body entrance dimension with roof air intake

- 955 mm, with sidemember height 258 mm and 290 mm

B2 - Body entrance dimension with low air intake

- 935 mm, with sidemember height 258 mm

- 925 mm, with sidemember height 290 mm

C - Sub-frame height = 180 mm

M - Air filter / air manifold duct

N - Dimension N = 1395 mm

3.3.2 Body entrances with vertical exhaust

Day cab

B1 - Body entrance dimension 530 mm

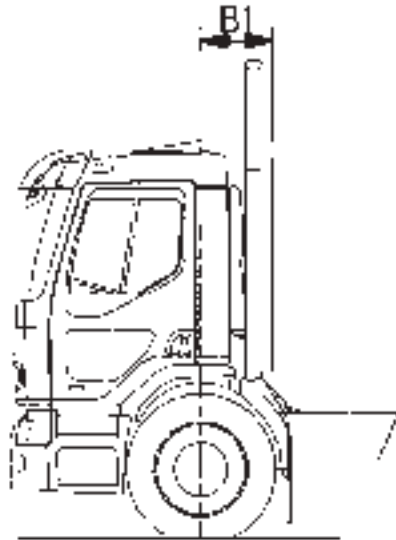

2 m cab

B1 - Body entrance dimension 925 mm

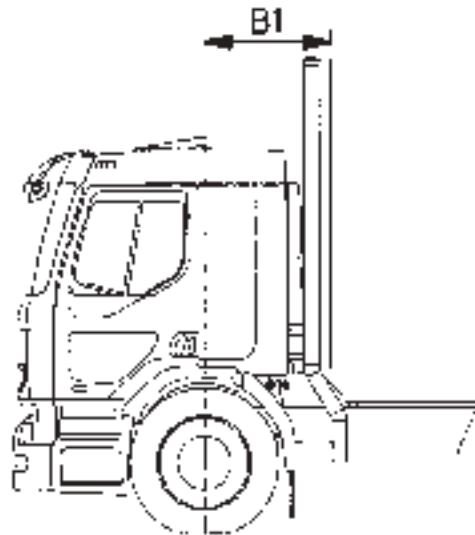

Sleeper cab

B1 - Body entrance dimension 1140 mm

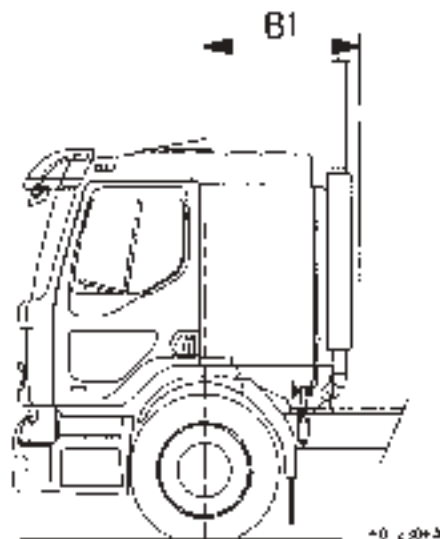

3.3.3 Presentation of the different air intakes



When changing the position of equipment or for trade applications (refuse collectors, road sweepers...), take care to not take up the place of the original filtration system or change its position. In fact, its size and position are defined to get optimum yield from the engine by avoiding the ingress of foreign matter (water, gravel, dust...).

When fitting the vehicle body, take care to maintain access to the air filter box so as to be able to replace the filter.

Roof air intake

Low air intake

Day cab

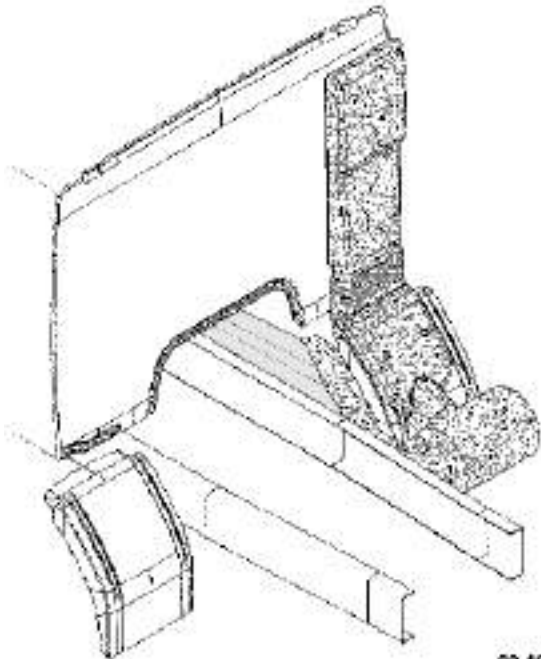

80 1248

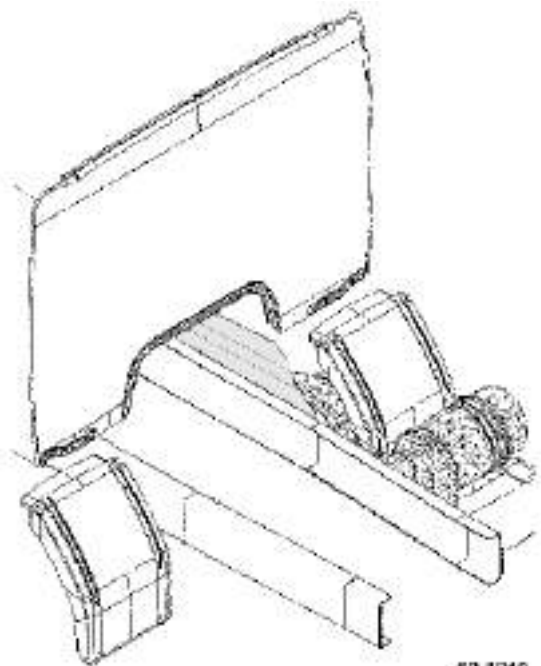

80 1249

Sleeper cab

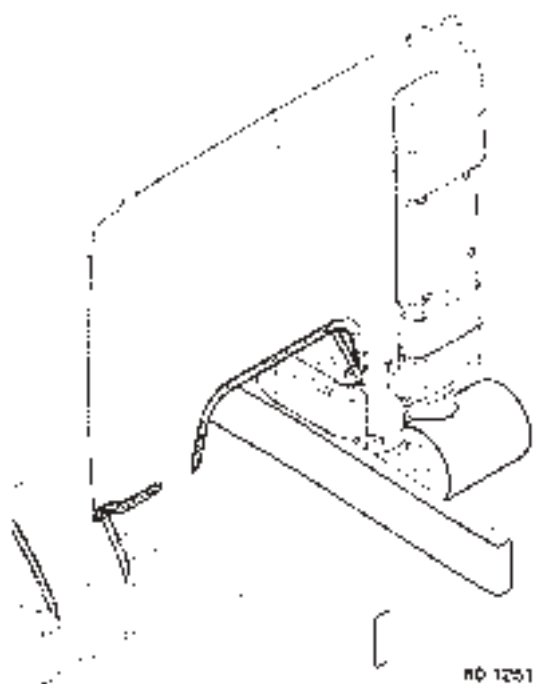

80 1251

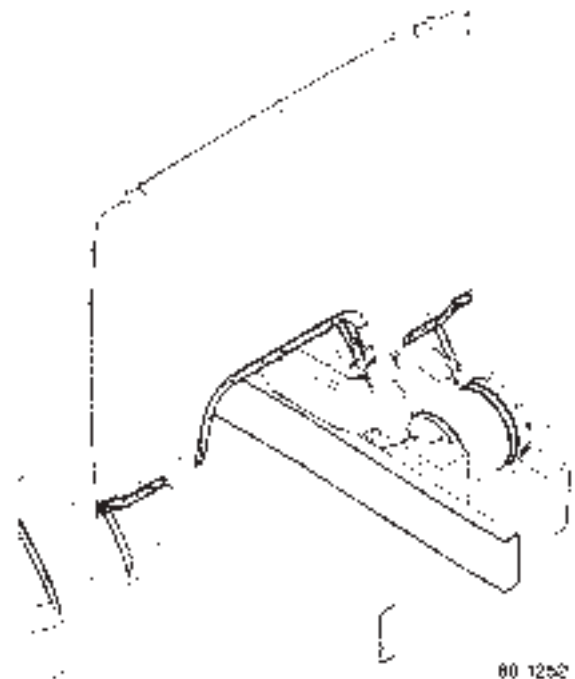

80 1252

3.4 Finishing of sub-frame entrance dimensions

Depending on:

- cab length,
- width of section making up the sub-frame,

the finishing of the sub-frame must be:

- symmetrical or asymmetrical (LH side entrance dimension different from that of the RH side),
- provided or not with horizontal cut-outs (reduction in width), allowing passage of the cab rear soundproofing screen and the roof level air intake.

To optimize the positioning of the sub-frame under the cab, it is necessary to observe the following recommendations:

Day cab

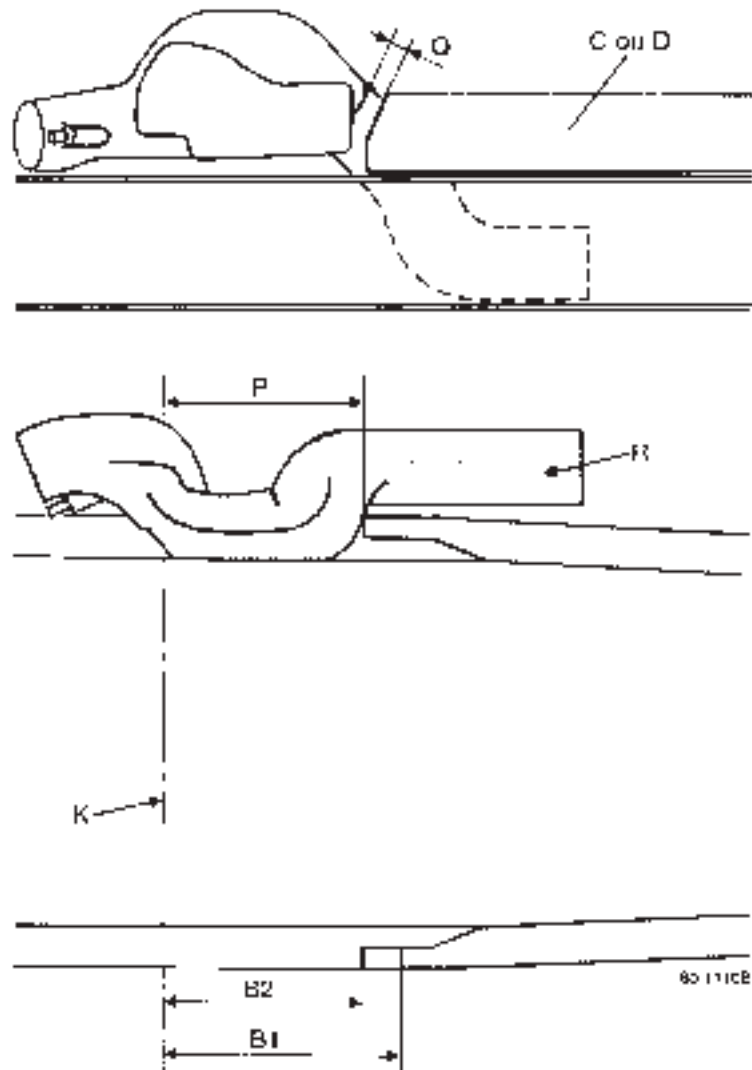

- B1 - Body entrance dimension with roof air intake = 465 mm
- B2 - Body entrance dimension with low air intake = 400 mm
- K - Front axle centre-line
- P - Sub-frame entrance dimension = 390 mm
- Q - Observe a clearance of 25 mm
- C.D - Sub-frame
- R - Air manifold

Large volume cab

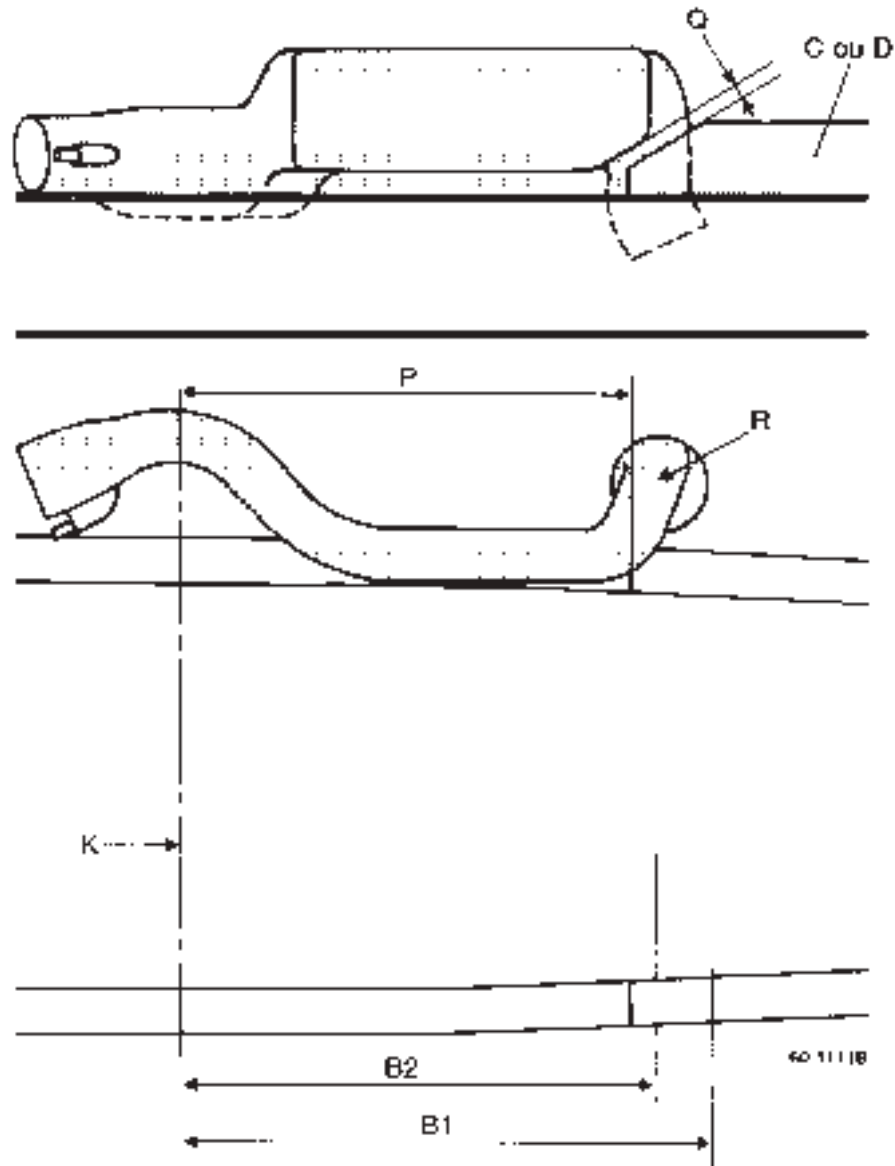

- B1 - Body entrance dimension with roof air intake = 955 mm
- B2 - Body entrance dimension with low air intake = 870 mm
- K - Front axle centre-line
- P - Sub-frame entrance dimension = 820 mm
- Q - Observe a clearance of 25 mm
- C.D - Sub-frame
- R - Air manifold

IMPORTANT

ADR vehicles (transport of dangerous materials) are equipped with a screen behind the cab and a screen on the gearbox. To limit cut-outs at the extremities of the sub-frame, the recommended width of the sections is 50 mm. If this width is greater, provide horizontal cut-outs (reduction in width) allowing passage of the rear screen.

3.5 Sub-frame sections

3.5.1 Minimum height according to range of suspension movement

A minimum sub-frame height is imposed by the range of movement of the rear suspension. The use of a sub-frame with insufficient height would result in possible damage to the underbody or equipment due to friction by the rear wheel tyres.

3.5.2 Sub-frame minimum inertia

4x2 Long Distance and Distribution rigids - GVW 18 tonnes, sidemembers 258 and 260 mm

Wheelbase	Min. sub-frame	* Modulus of inertia (I/V) in mm ³
6785	140 x 70 x 7	78650
6400	100 x 70 x 7	49890
5960	60 x 70 x 7	24970
5575	60 x 70 x 7	24970
5190	60 x 70 x 7	24970
4750	60 x 70 x 7	24970
4365	60 x 70 x 7	24970
4090	60 x 70 x 7	24970
3815	60 x 70 x 7	24970

4x2 Long Distance and Distribution rigids - GVW 18 tonnes*, sidemembers 290 and 292 mm

Wheelbase	Min. sub-frame	* Modulus of inertia (I/V) in mm ³
6785	120 x 70 x 7	63800
6400	120 x 70 x 7	63800
5960	120 x 70 x 7	63800
5575	100 x 70 x 7	49890
5190	60 x 70 x 7	24970
4750	60 x 70 x 7	24970
4365	60 x 70 x 7	24970
4090	60 x 70 x 7	24970
3815	60 x 70 x 7	24970

** Vehicle with 8 tonnes on front axle

6x2 Long Distance and Distribution rigids - GVW 26 tonnes, sidemembers 258 and 260 mm

Wheelbase	Min. sub-frame	* Modulus of inertia (I/V) in mm ³
6400	180 x 70 x 7	111500
5960	160 x 70 x 7	94950
5575	160 x 70 x 7	94950
5190	140 x 70 x 7	78650
4750	140 x 70 x 7	78650
4365	120 x 70 x 7	63800
4090	120 x 70 x 7	63800
3815	100 x 70 x 7	49890

6x2 Long Distance and Distribution rigids - GVW 26 tonnes, sidemembers 290 and 292 mm

Wheelbase	Min. sub-frame	* Modulus of inertia (I/V) in mm ³
6400	160 x 70 x 7	94950
5960	140 x 70 x 7	78650
5575	140 x 70 x 7	78650
5190	100 x 70 x 7	49890
4750	80 x 70 x 7	36940
4365	60 x 70 x 7	24970
4090	60 x 70 x 7	24970
3815	60 x 70 x 7	24970

6x2/4 Long Distance and Distribution rigids - GVW 26 tonnes, sidemembers 290 mm

Wheelbase	Min. sub-frame	* Modulus of inertia (I/V) in mm ³
5740	140 x 70 x 7	78650
5245	100 x 70 x 7	49890
4805	80 x 70 x 7	36940
4475	60 x 70 x 7	24970

Reminder of formula for calculating maximum normal surface stress

$$\sigma = \frac{Mf}{\left(\frac{I}{v}\right)}$$

- σ : maximum stress at surface edge (N/mm²)
- Mf : bending moment (Nm)
- I : surface quadratic moment (mm⁴)
- v : distance between section extremity and neutral fibre (mm)

3.5.3 Discontinuous sub-frames (2-part)

RENAULT V.I. authorize the mounting of 2-part sub-frames for tankers, refuse collectors and demountable bodies.

Only on 290 and 292 mm sidemembers for 4x2, 6x2, 6x2/4 axle spreads.

Min. sub-frame section 120x70x7 mm (modulus of inertia I/V = 63800 mm³).

The gap between the forward and rearward 1/2 sub-frames shall be limited to a minimum.

4x2 diagram

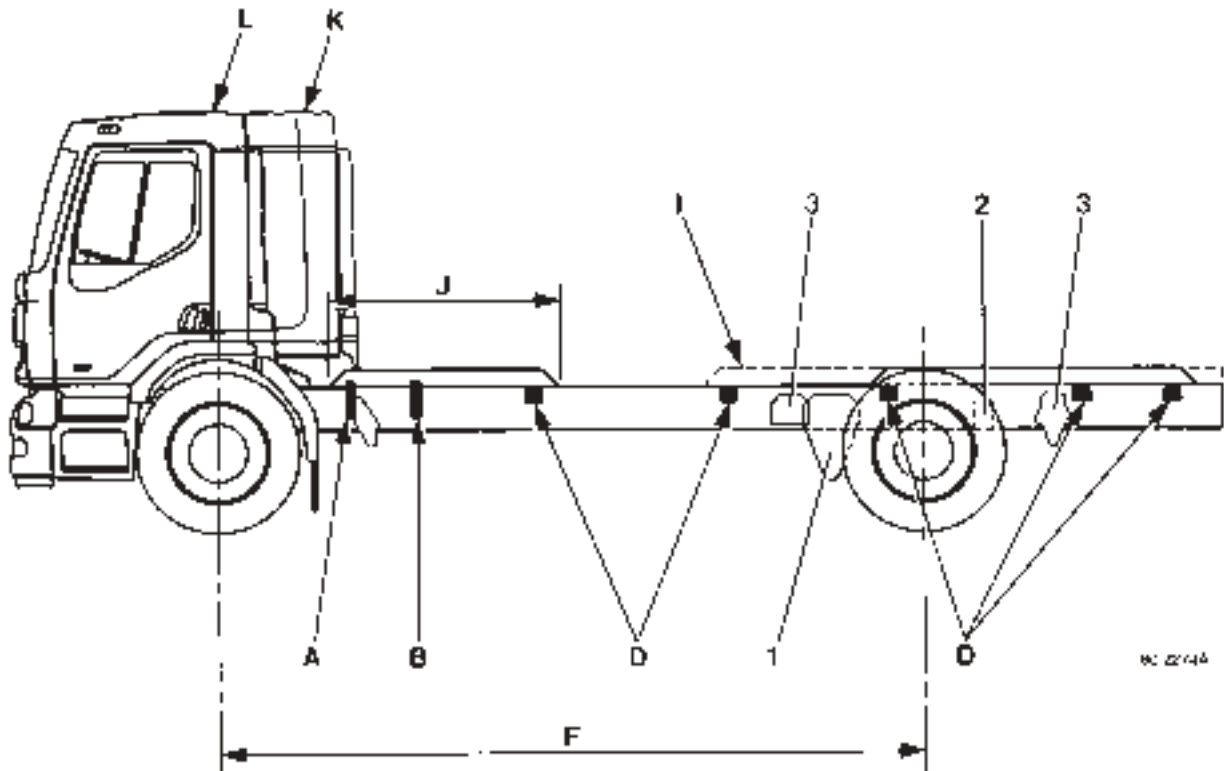

- A - Flexible attachment
- B - Semi-flexible attachment
- D - Rigid attachment
- I - For long wheelbases: extension (in front of spring hangers) of rear 1/2 sub-frame
- J - = 1500 mm min.
- K - Sleeper cab
- L - Day cab
- 1 - Air suspension hanger
- 2 - Air spring bracket
- 3 - Mechanical suspension hanger

6x2 - 6/2x4 diagram

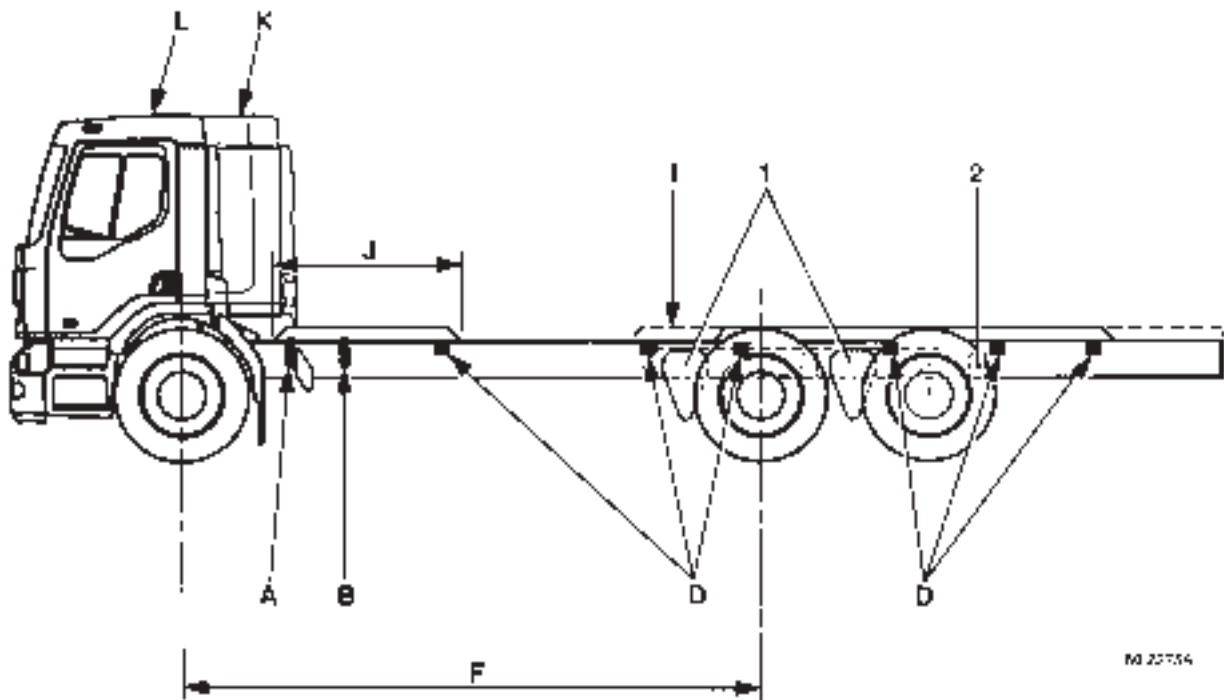

- A - Flexible attachment
- B - Semi-flexible attachment
- D - Rigid attachment
- I - For long wheelbases: extension (in front of spring hangers) of rear 1/2 sub-frame
- J - = 1500 mm min.
- K - Sleeper cab
- L - Day cab
- 1 - Air suspension hangers
- 2 - Air spring bracket

NOTE

The rear 1/2 sub-frame must be held by at least three rigid fastenings.
The first attachment should not be more than a distance **F** away from the front axle centre-line.
F = distance between front axle and rear drive axle (foremost rear axle for 6x2/4 rigids).

The forward sub-frame must be held by:
- 3 fastenings: flexible at the front, semi-flexible in the middle and rigid at the rear.
It must follow the necking of the sidemembers with a min. length of 1500 mm.

In the case of a sleeper cab, the right-hand flexible attachment may be deleted (proximity to air intake).

3.5.4 Continuous sub-frames

- The body sub-frame must follow the necking of the sidemembers.
- The body sub-frame must be applied perfectly flat over the entire length of the chassis.
- For certain body configurations (e.g. municipal vehicles), it is permitted to reduce the height of the sub-frame on condition that its inertia remains equivalent to the min. value recommended for the sub-frame. In this case, sudden changes in inertia must be avoided.
- Check the range of movement of the roadwheels with the vehicle laden and the max. cant (including snow chains).

Inertia stop

All bodies or equipment must be fitted with an inertia stop to the aft of each sidemember to retain the body against motion.

When the vehicle is equipped with a tailgate, the flanges play the part of inertia stop.

Two holes drilled at a pitch of 55 mm are available after the last bracket for positioning an inertia stop.

3.6 Attachment of bodywork

It is essential to comply with the stipulations hereafter for attaching bodywork of equipment to our vehicles.

For special cases, contact the RENAULT V.I. Product Application Department.

The bodywork must be correctly attached so that both the static and dynamic stresses are freely transmitted without causing excessive local strain, which could prejudice the reliability of the chassis frame or affect the road behaviour of the vehicle.

The use of brackets mounted in production to the chassis is compulsory.

The fastening of body sub-frames or undercarriages must be carried out according to the recommendations defined in this document (consult the "Bodywork fastening type" chapter).

Sub-frames or undercarriages must be continuous and fit perfectly over the entire length of the chassis. They may however be intermittent for a few specific applications (e.g. tankers). In such case, their attachment remains entirely under the bodybuilder's responsibility.

Sub-frames or undercarriages should always be tapered towards the front (i.e. under the cab), so as to avoid sudden variations in inertia.

Behind-cab overall dimensions are given in the "Cab footprint" and "Behind-cab surrounds" chapters.

Protection against exhaust heat radiation: the closeness of the bodywork to the exhaust pipe and the fitting of certain accessories (electric retarder, etc...) may require the installation of a suitable heat shield by the bodybuilder.

Bans

WE FORBID:

- Attachment of sub-frames by U-bolts, clamps or equivalent systems (hooks).
- Use, drilling or welding of spring hangers.
- Any modification to: chassis, driveline, suspension (except if contained in the Guide for Fitting Bodywork).
- Attachment of sub-frames by welding to sidemembers.
- Drilling of stiffener gussets.
- Welding, notching of sidemembers, gussets or cross-members.
- Use or modification of our nut and bolt hardware for the attachment of a body or a sub-frame (except for special cases specified in this document).
- Dismantling of brackets attached to the chassis (unless specified otherwise in this document).
- Insertion of wooden blocks between sub-frames and the chassis.

3.7 Attachment of sub-frames to brackets

3.7.1 Day cab guiding and fastening zone

- A - Flexible attachment (first bracket)
- B - Semi-flexible attachment (second bracket)
- C - Rigid attachment (all other brackets)

E (mm)	F (mm)	H (mm) RH side	H (mm) LH side
258/260 4x2 and 6x2 rigid	857.5	1352.5	
290/292 4x2 and 6x2 rigid	885	1325	
290 6x2/4 rigid		1490	1545

- D - Front axle centre-line
- E - Sidemembers height
- F - Flexible fastening position (A) (first bracket) in relation to front axle centre-line
- G - Lateral guiding and elastic fastening zone
- H - Semi-flexible fastening position (B) (second bracket) in relation to front axle centre-line
- L - Guiding and rigid fastening zone

(See following pages).

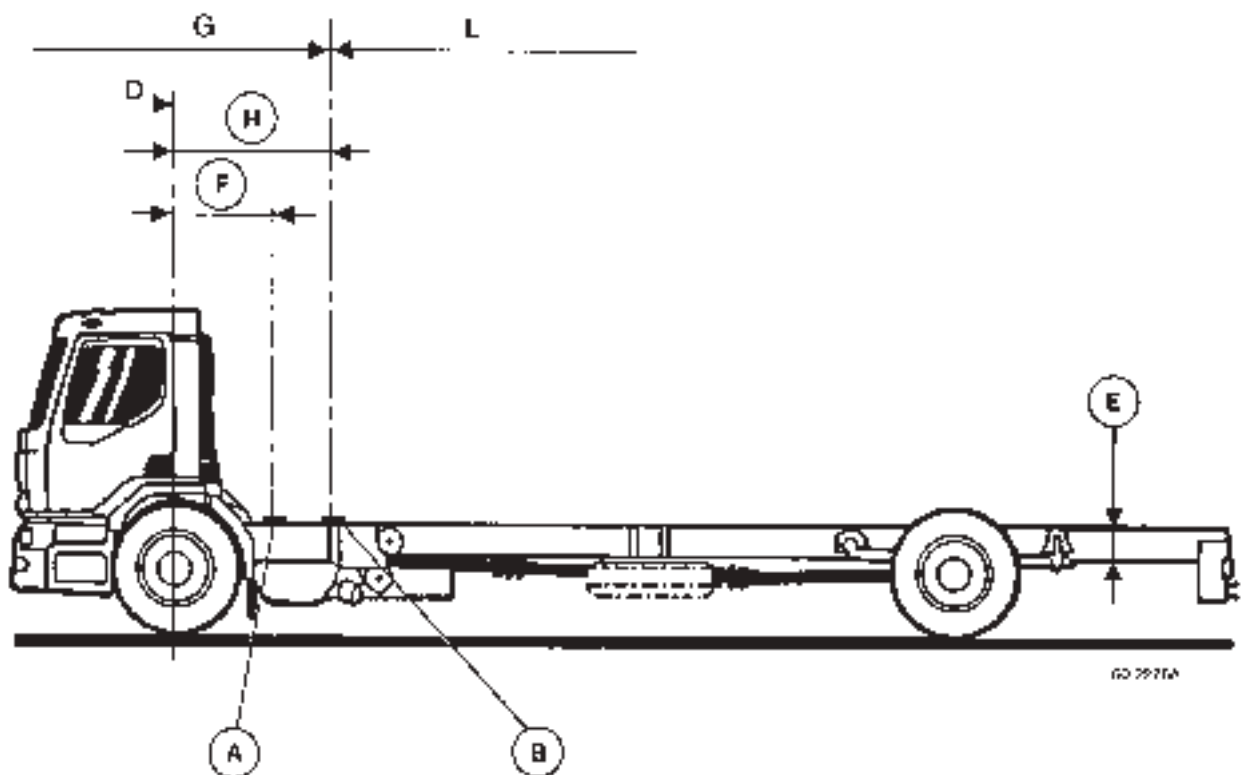

3.7.2 Sleeper cab guiding and fastening zone

- A - Flexible attachment (first bracket)
- B - Semi-flexible attachment (second bracket)
- C - Rigid attachment (all other brackets)

E (mm)	F (mm) RH side	F (mm) LH side	H (mm) RH side	H (mm) LH side
258/260 4x2 and 6x2 rigid	1352,5		2067,5	2122,5
290/292 4x2 and 6x2 rigid	1490	1490		
290 6x2/4 rigid		1545		2067,5

- D - Front axle centre-line
- E - Sidemembers height
- F - Flexible fastening position (A) (first bracket) in relation to front axle centre-line
- G - Lateral guiding and elastic fastening zone
- H - Semi-flexible fastening position (B) (second bracket) in relation to front axle centre-line
- L - Guiding and rigid fastening zone

(See following pages).

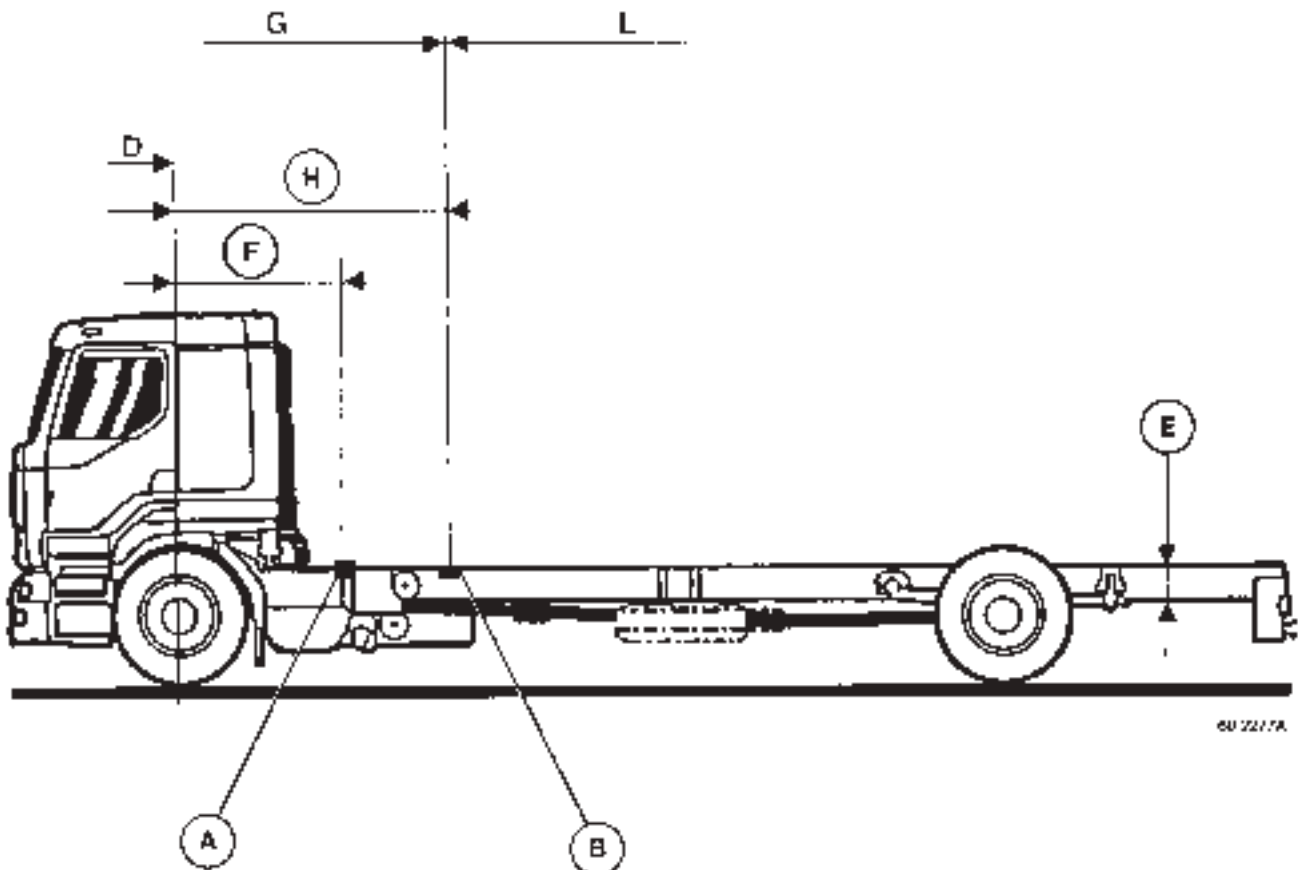

Mounting conditions

- 1 - raised brackets (first and second brackets) for the day cab - one single for the sleeper cab
- 2 - flush brackets (other brackets)

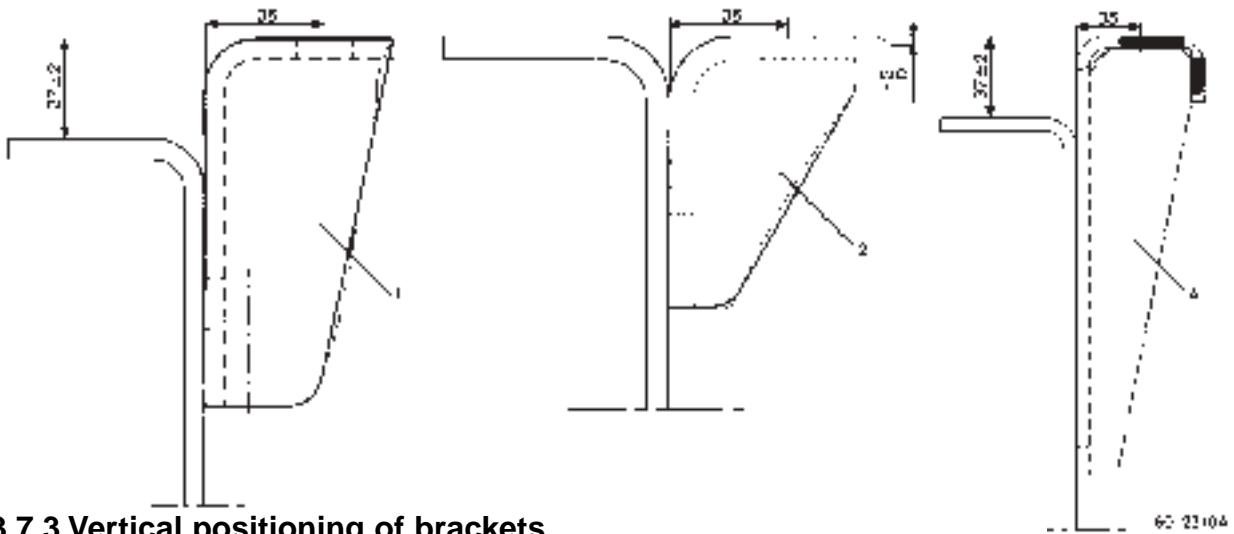

3.7.3 Vertical positioning of brackets

Sidemembers height 258/260 mm

Two bracket assemblies are made on the RENAULT PREMIUM chassis:

- The first and second brackets (1) are raised in relation to the other brackets or the day cab - one single for the sleeper cab.
 - All the other brackets (2) are flush with the top face of the sidemembers.
- The size and position of the slotted hole (3) is the same for all the brackets (1) and (2).

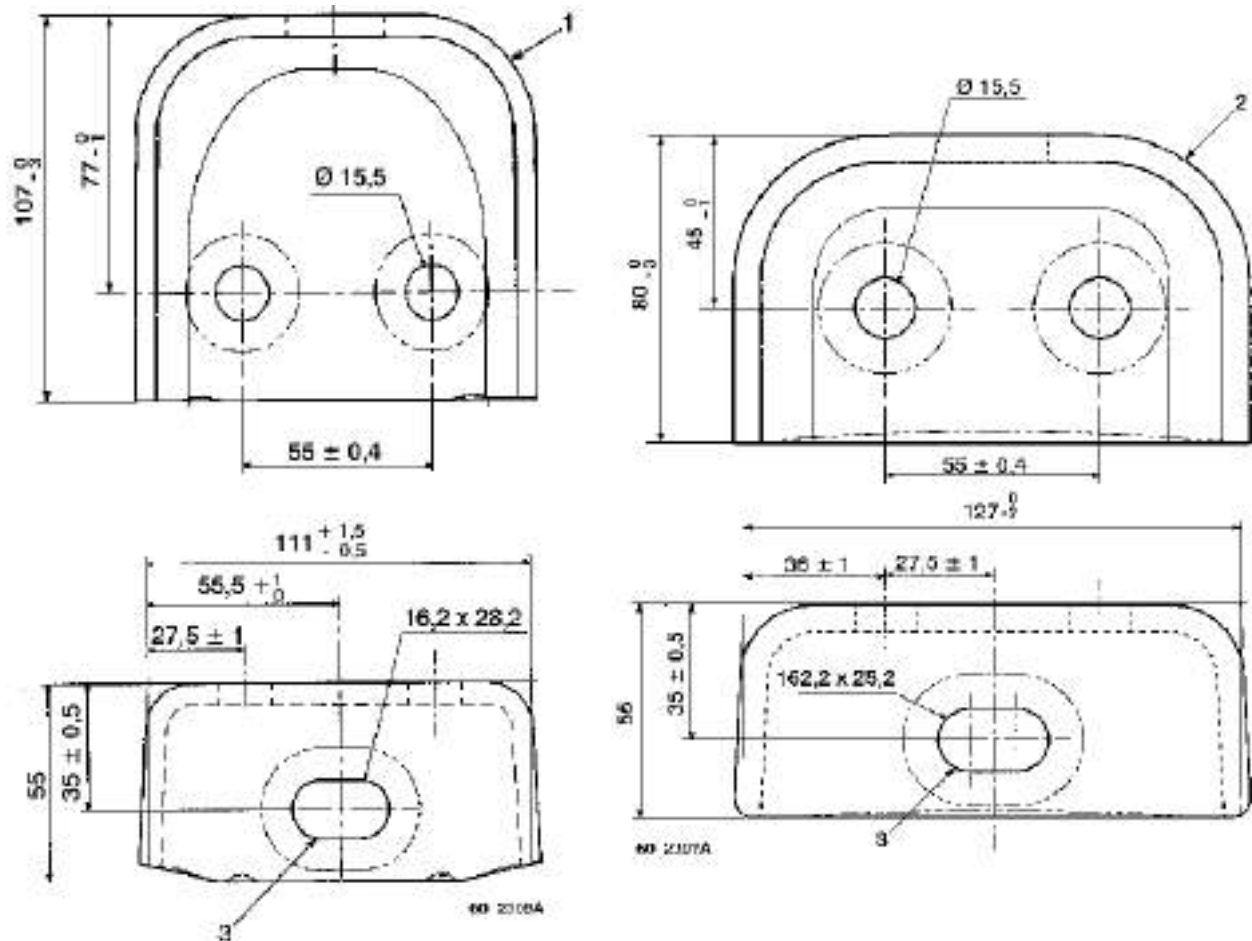

Sidemembers height 290/292 mm

Two bracket assemblies are made on the RENAULT PREMIUM chassis:

- The first and second brackets (4) are raised in relation to the other brackets or the day cab - one single for the sleeper cab.
- All the other brackets (1) are flush with the top face of the sidemembers.

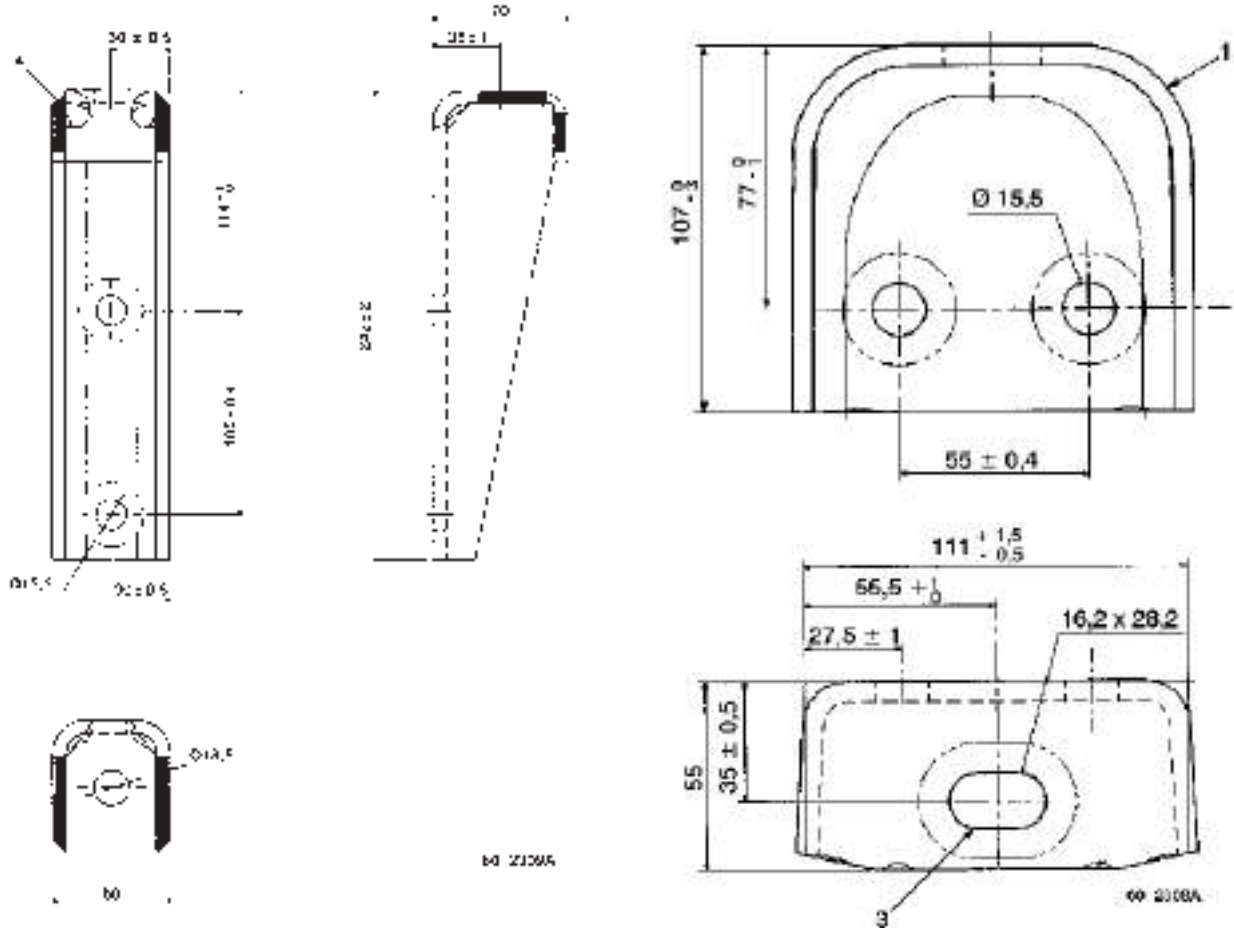

3.7.4 Transversal positioning of brackets

- * 872 for the 6x2/4 rigid
- 890 for the other rigid

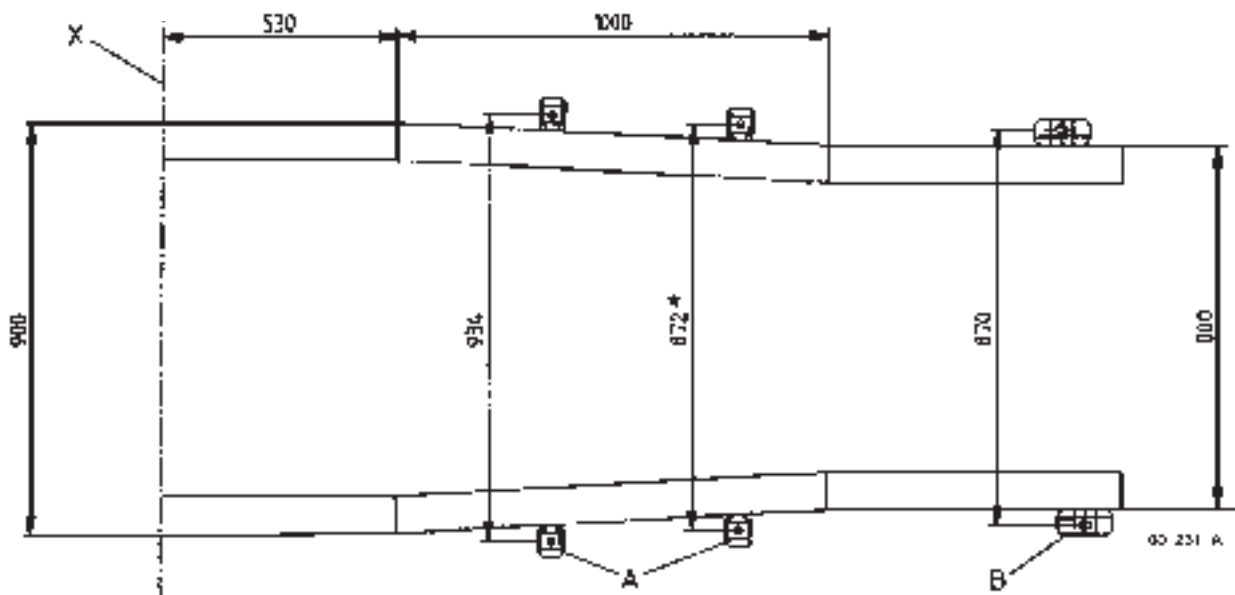

3.7.5 Types of bodywork attachment

A - Flexible attachment (258/260 mm sidemember)

- 1 - Hexagon bolt M 14 x 150 x 90, class 10.9
- 2 - 2 plain washers 14 x 30 x 5
- 3 - 6 cone washers: ("BELLEVILLE" type)
i/d 14.5 mm
o/d 35 mm
thickness 1.8 mm
unit preload 400 kg
- 4 - Nut DAH M 14 class 10, or other locknut except nut with nylon ring (e.g. Nyloc)
- a - Clearance: 10 to 15 mm max.
- b - Clearance: 2 mm max.
- Tightening at 50% of the deflection:

$$\frac{6 \times 1,2 \text{ (deflection)}}{2} = 3,6 \text{ mm}$$

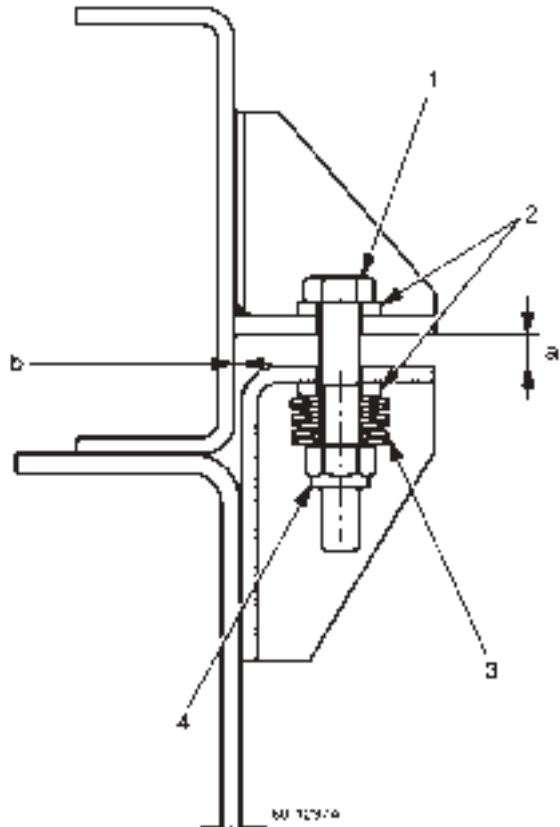

A - Flexible attachment (290/292 mm sidemember)

- 1 - Hexagon bolt M 14 x 150 x 90, class 10.9
- 2 - 2 plain washers 14 x 30 x 5
- 3 - 6 cone washers: ("BELLEVILLE" type)
i/d 14.5 mm
o/d 35 mm
thickness 1.8 mm
unit preload 400 kg
- 4 - Nut DAH M 14 class 10, or other locknut except nut with nylon ring (e.g. Nyloc)
- a - Clearance: 10 to 15 mm max.
- b - Clearance: 2 mm max.
- Tightening at 50% of the deflection:

$$\frac{6 \times 1,2 \text{ (deflection)}}{2} = 3,6 \text{ mm}$$

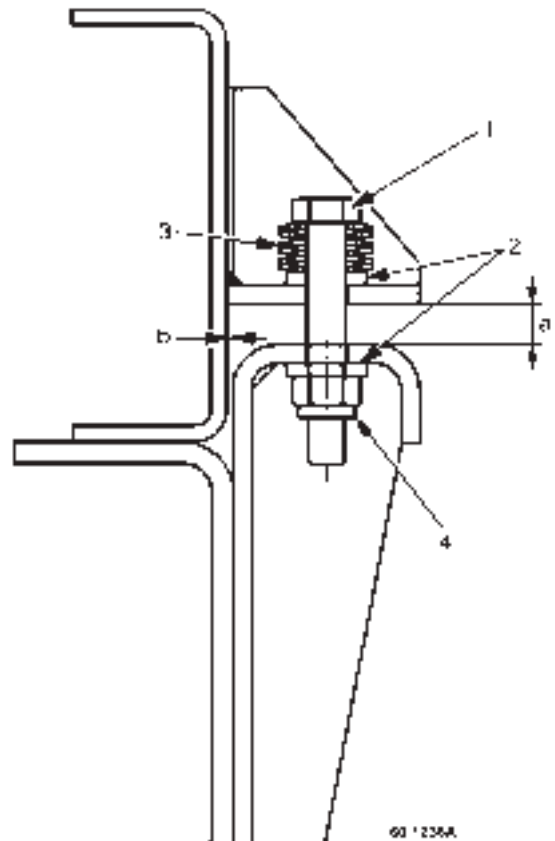

B - Semi-flexible attachment (258/260 mm sidemember)

Day cab

- 1 - Hexagon bolt M 14 x 150 x 110, class 10.9
- 2 - 2 plain washers 14 x 30 x 5
- 3 - Steel spacer 15x38-65 (min.). After cutting, true both faces.
- 4 - Flanged nut DRH M 14 class 10 or other locknut except nut with nylon ring (e.g. Nyloc)
- a - Clearance: 1 to 2 mm before tightening
- b - Clearance 2 mm max.
- Tighten to standardized torque (see chapter A32).

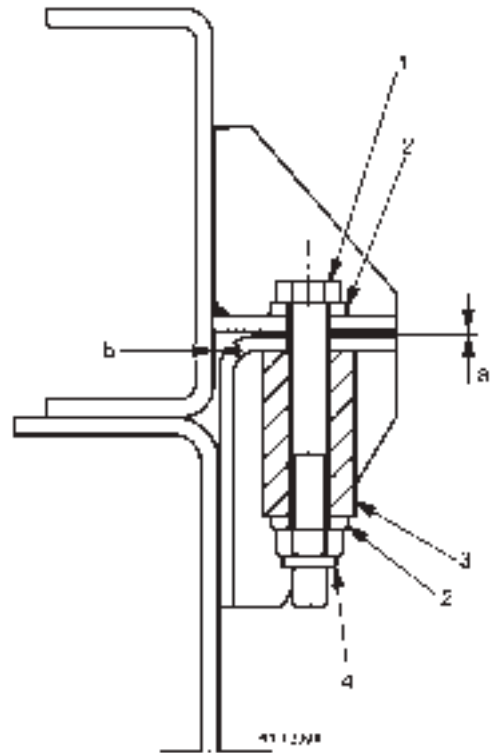

B - Semi-flexible attachment (290/292 mm sidemember)

Day cab

- 1 - Hexagon bolt M 14 x 150 x 110, class 10.9
- 2 - 2 plain washers 14 x 30 x 5
- 3 - Steel spacer 15x38-65 (min.). After cutting, true both faces
- 4 - Flanged nut DRH M 14 class 10 or other locknut except nut with nylon ring (e.g. Nyloc)
- a - Clearance: 1 to 2 mm before tightening
- b - Clearance 2 mm max.
- Tighten to standardized torque (see chapter A32).

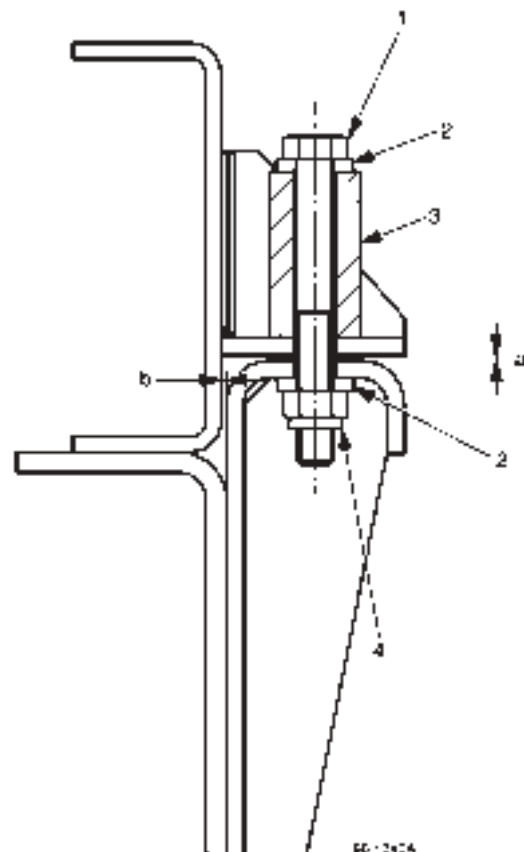

RENAULT V.I. 06/01

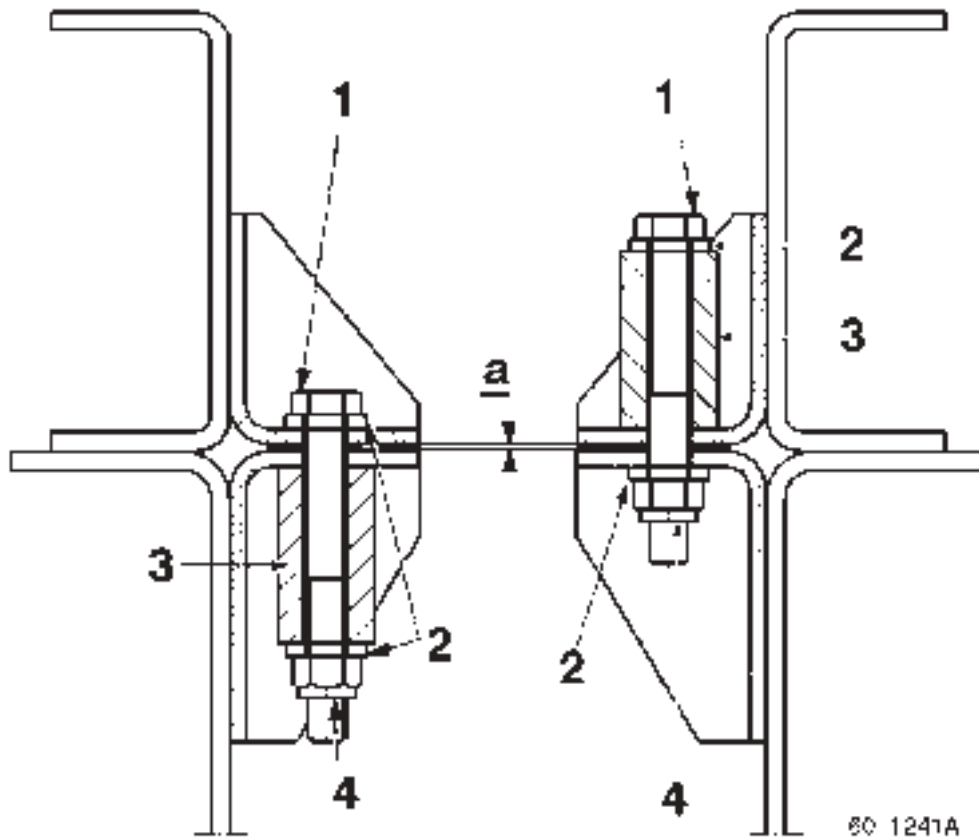

B - Semi-flexible attachment (258/260 and 290/292 mm sidemembers)

Sleeper cab

- 1 - Hexagon bolt M 14 x 150 x 110, class 10.9
- 2 - 2 plain washers 14 x 30 x 5
- 3 - Steel spacer 15x38-65 (min.) positioned above or below, depending on surrounds.
After cutting, true both faces)
- 4 - Flanged nut DRH M 14 class 10 or other locknut except nut with nylon ring (e.g. Nyloc)
- a - Clearance: 1 to 2 mm before tightening
- Tighten to standardized torque (see chapter A32).

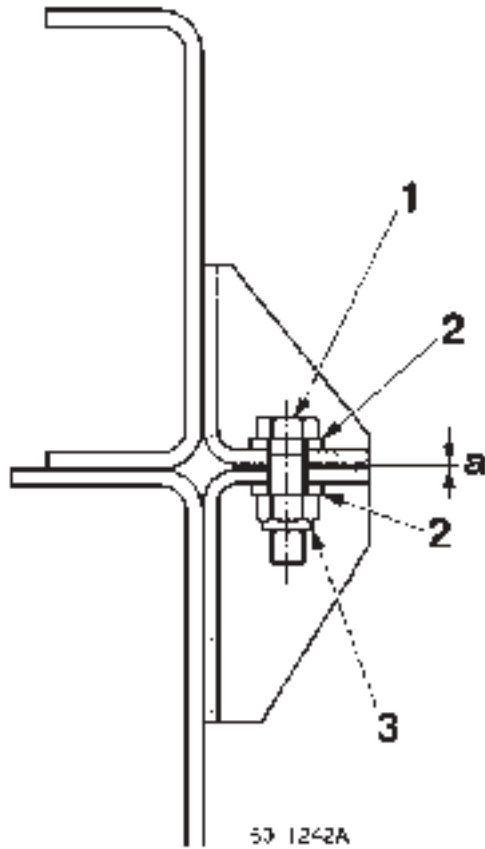

C - Rigid attachment (258/260 and 290/292 mm sidemembers)

- 1 - Hexagon bolt M 14 x 60, class 10.9
- 2 - 2 plain washers 14 x 30 x 5
- 3 - Nut DRH M 14 class 10 or other locknut except nut with nylon ring (e.g. Nyloc)
- a - Clearance: 1 to 2 mm before tightening, then tighten to standardized torque (see chapter A32)

3.8 Longitudinal positioning of brackets on chassis

Sidemembers height 258/260 mm

Day cab

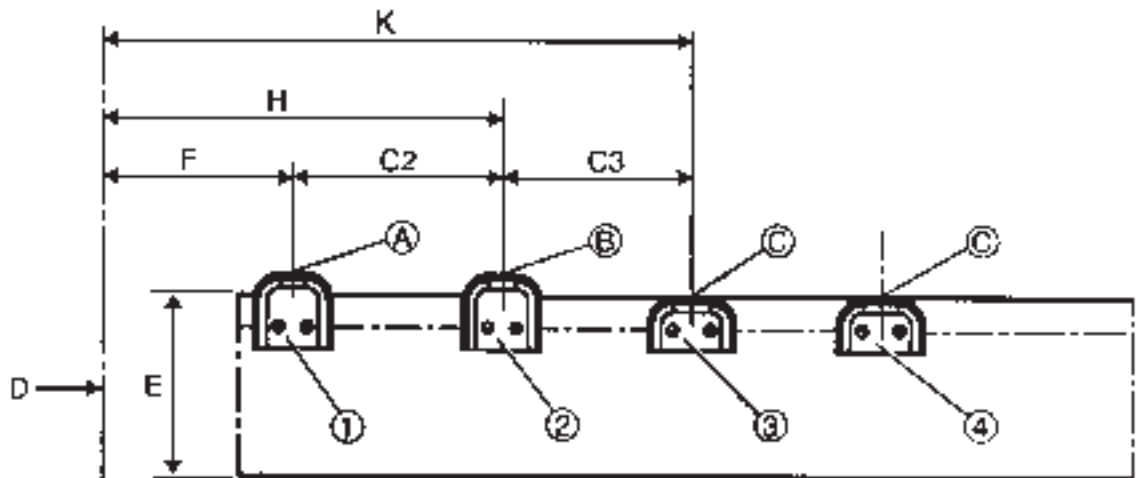

Sleeper cab

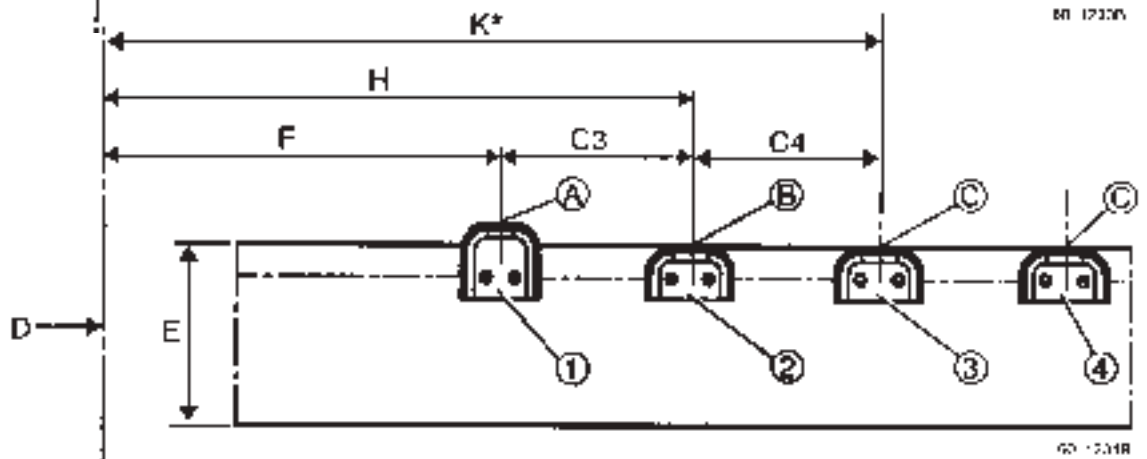

Brackets	1	2	3	4
Flexible attachment	A			
Semi-flexible attachment		B		
Rigid attachment			C	C

Dimension		F	C2	C3	H	K
Day cab	Sidemember	D	857,5	495	715	2067,5
		G			770	
Sleeper cab	Sidemember	D	1352,5		715	*
		G			770	

A - Flexible attachment (first bracket)

B - Semi-flexible attachment (second bracket)

C - Rigid attachment (all other brackets)

D - Front axle centre-line

E - Sidemembers height

F - Flexible fastening position (A) (first bracket) in relation to front axle centre-line

H - Semi-flexible fastening position (B) (second bracket) in relation to front axle centre-line

K - Rigid fastening position (C) (third bracket) in relation to front axle centre-line

* variable according to wheelbase: $K^* = H + C4$

D = Right-hand sidemember

G = Left-hand sidemember

Sidemembers
height 290/292 mm

Day cab

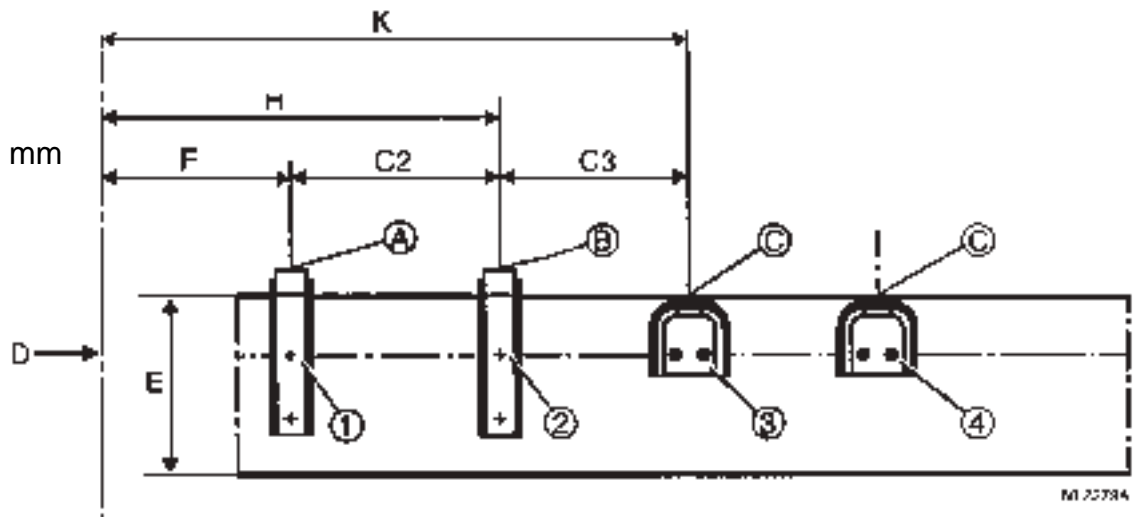

Sleeper cab

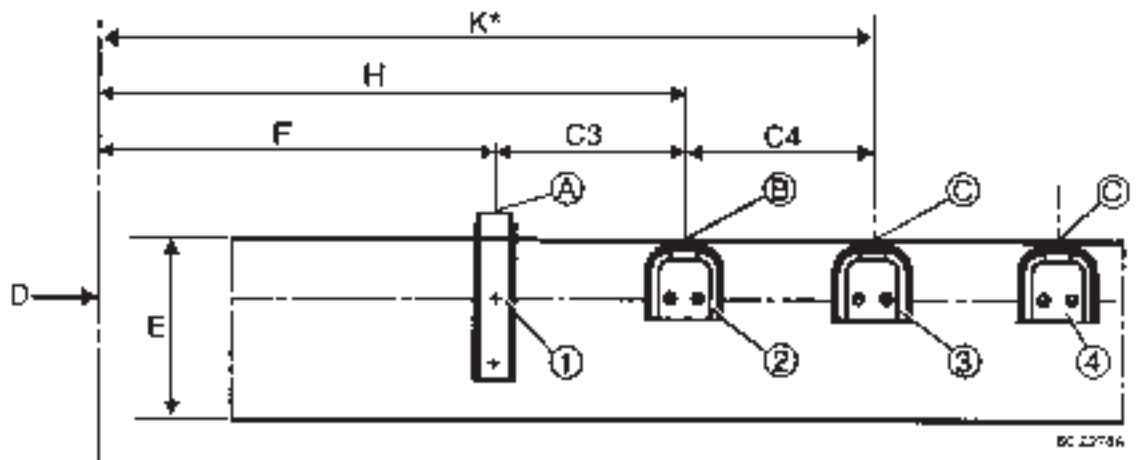

Brackets	1	2	3	4
Flexible attachment	A			
Semi-flexible attachment		B		
Rigid attachment			C	C

Dimension		F	C2	C3	H	K		
Day cab	Sidemember	D	885	440	742,5	1325	2067,5	
		G		797,5	2122,5			
	Sidemember 6x2/4	D		605	577,5	1490	2067,5	
		G		660	522,5	1545		
Sleeper cab	Sidemember	D	1325		742,5	2067,5	*	
		G			797,5	2122,5		
	Sidemember 6x2/4	D		1490		577,5		2067,5
		G		1545		522,5		

- A - Flexible attachment (first bracket)
- B - Semi-flexible attachment (second bracket)
- C - Rigid attachment (all other brackets)
- D - Front axle centre-line
- E - Sidemembers height
- F - Flexible fastening position (A) (first bracket) in relation to front axle centre-line
- H - Semi-flexible fastening position (B) (second bracket) in relation to front axle centre-line
- K - Rigid fastening position (C) (third bracket) in relation to front axle centre-line
- * variable according to wheelbase: $K^* = H + C4$
- D = Right-hand sidemember
- G = Left-hand sidemember

4x2 rigid - 18 tonnes, mechanical suspension

E	L	C1	C2	C3	C4	C4*	C5	C5*	C6	C6*	C7	C8	C9	C10	C11	C12																
3815	D	857,5 885**	495 440**	715 742,5**	385		990		605																							
	G			770 797,5**	330	1045		880																								
4090	D					715 742,5**	825										825		605													
	G			770 797,5**	770	330	1265																									
4365	D					715 742,5**	825										1100				825											
	G			770 797,5**	770	605	1265																									
4750	D					715 742,5**	935										550		825		605	825										
	G			770 797,5**	880	715	715																									
5190	D					715 742,5**	935										605		385	550	825											
	G			770 797,5**	880	715	605																									
5575	D					715 742,5**	935										825		440		935	605	825									
	G			770 797,5**	880	550	825																									
5960	D					715 742,5**	935										880							935								
	G			770 797,5**	880	770	825																									
6400	D					715 742,5**	935										825								770		495			825	935	
	G			770 797,5**	880	935	825																									
6785	D			715 742,5**	935	825						935	605			495	880															
	G	770 797,5**	880	935	825																											

* With spare wheel carrier

** With 290 and 292 mm sidemembers (8 tonnes at front)

Bodywork attachment kit

Bodywork attachment kit (all vehicles)
KIT ref. N° 50 01 839 172

4x2 rigid - 18 tonnes, mechanical suspension

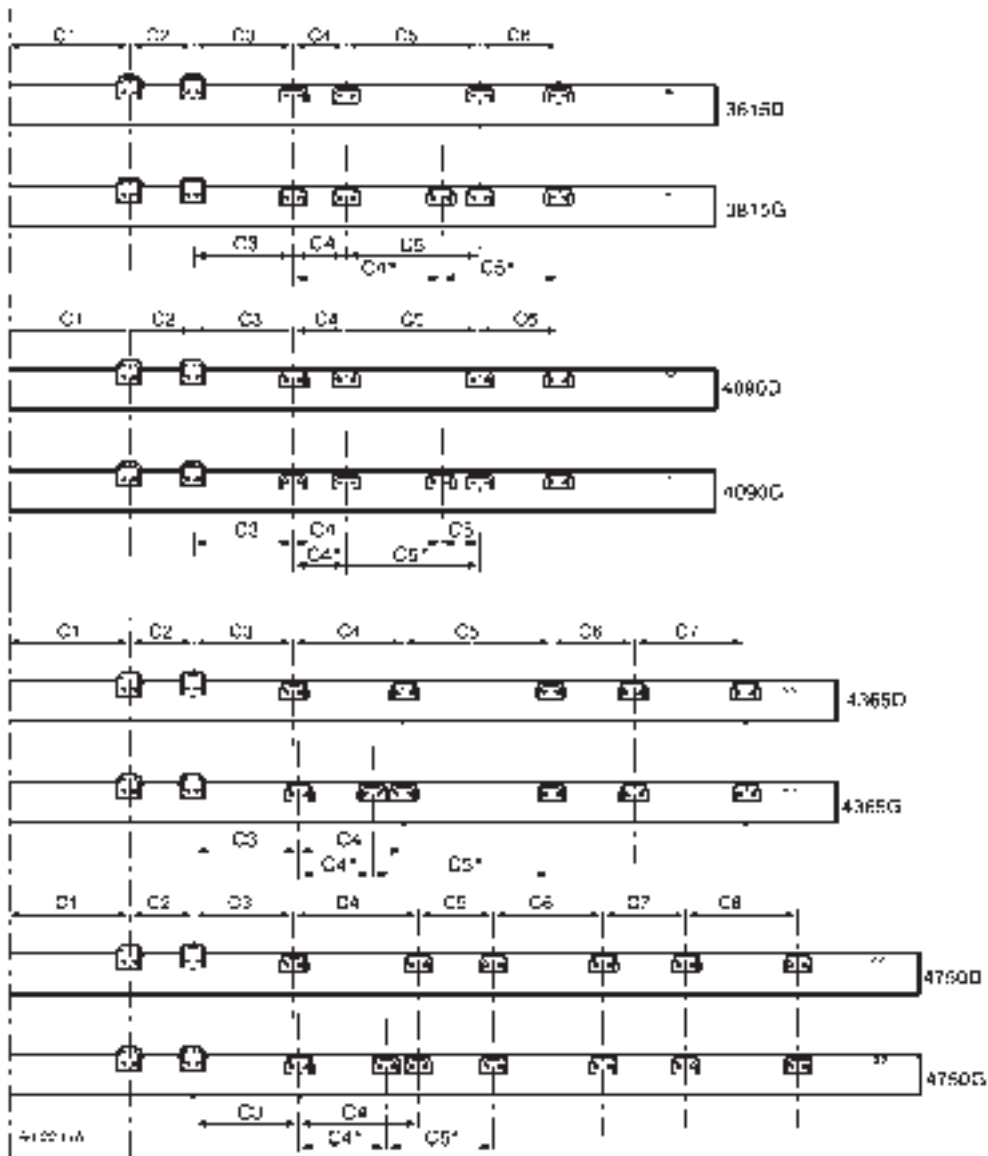

4x2 rigid - 18 tonnes, mechanical suspension

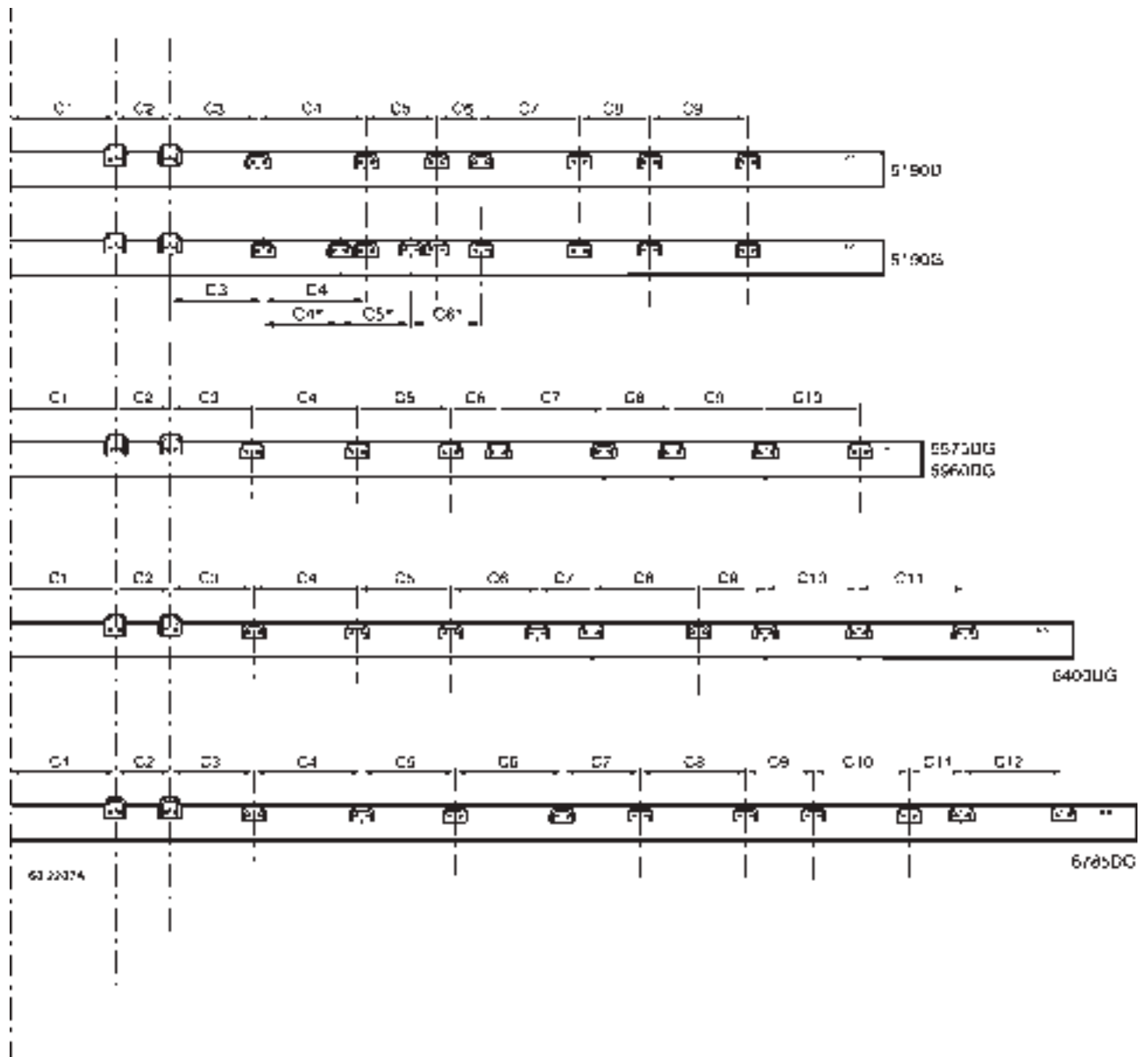

4x2 rigid - 19 tonnes, mechanical suspension

E	L	C1	C2	C3	C4	C4*	C5	C5*	C6	C6*	C7	C8	C9	C10	C11	C12			
3815	D	885	440	742,5	385		990		605										
	G			797,5	330														
4090	D					742,5	825	330	825		1265	605	825						
	G			797,5	770														
4365	D					742,5	825	605	1100		1265								
	G			797,5	770														
4750	D					742,5	935	715	550		715	825		605	825				
	G			797,5	880														
5190	D					742,5	935	715	605		605	385	550	825			880		
	G			797,5	880														
5575	D					742,5	935		825			440		935	605	825			
	G			797,5	880														
5960	D					742,5	935		880					935			990		
	G			797,5	880														
6400	D					742,5	935		825			770		495					825
	G			797,5	880														
6785	D					742,5	935					935		715	935	605	825	495	
	G			797,5	880														

* With spare wheel carrier

Bodywork attachment kit

Bodywork attachment kit (all vehicles)
KIT ref. N° 50 01 839 172

4x2 rigid - 19 tonnes, mechanical suspension

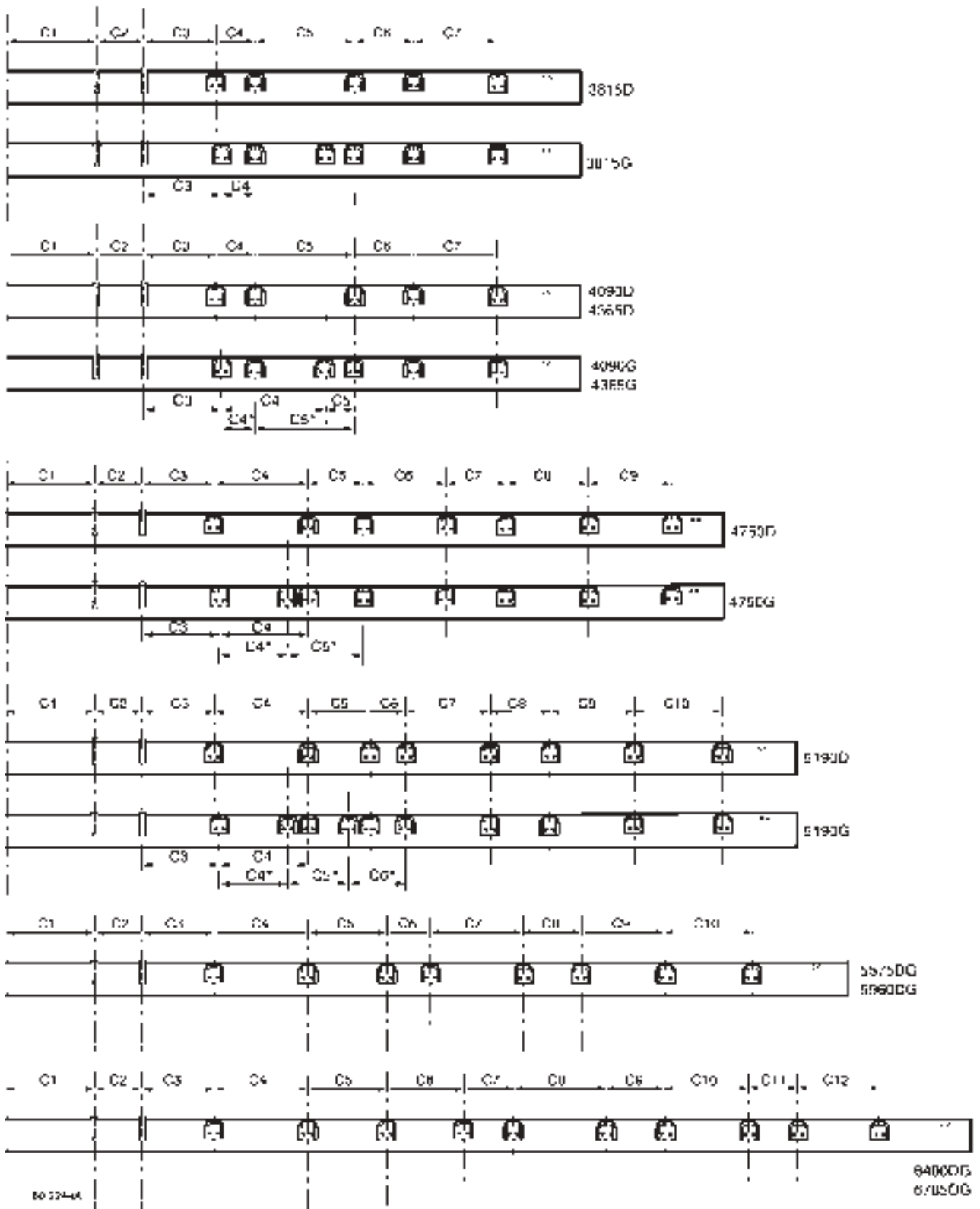

4x2 rigid - 18 tonnes, air suspension

E	L	C1	C2	C3	C4	C4*	C5	C5*	C6	C7	C8	C9	C9*	C10	C10*	C11	C12			
3815	D	857,5 885**	495 440**	715 742,5**	825		990		770											
	G			770 797,5**	770															
4090	D			715 742,5**	1100															
	G			770 797,5**	1045															
4365	D			715 742,5**	825		605	550	715	990	770									
	G			770 797,5**	770															
4750	D			715 742,5**	935		715	825	990											
	G			770 797,5**	880															
5190	D			715 742,5**	935		715	605	770	660		990	770							
	G			770 797,5**	880															
5575	D			715 742,5**	935			825		825										
	G			770 797,5**	880															
5960	D			715 742,5**	935			880				770	385	990	770		935	770		
	G			770 797,5**	880															
6400	D			715 742,5**	935			825					880							
	G			770 797,5**	880															
6785	D	715 742,5**	935						935	715	385	990		770			825	770		
	G	770 797,5**	880																	

* With spare wheel carrier

** Cross-member under chassis, for E = 5960 and 4750 mm

*** With 290 and 292 mm sidemembers (8 tonnes at front)

Bodywork attachment kit

Bodywork attachment kit (all vehicles)

KIT ref. N° 50 01 839 172

4x2 rigid - 18 tonnes, air suspension

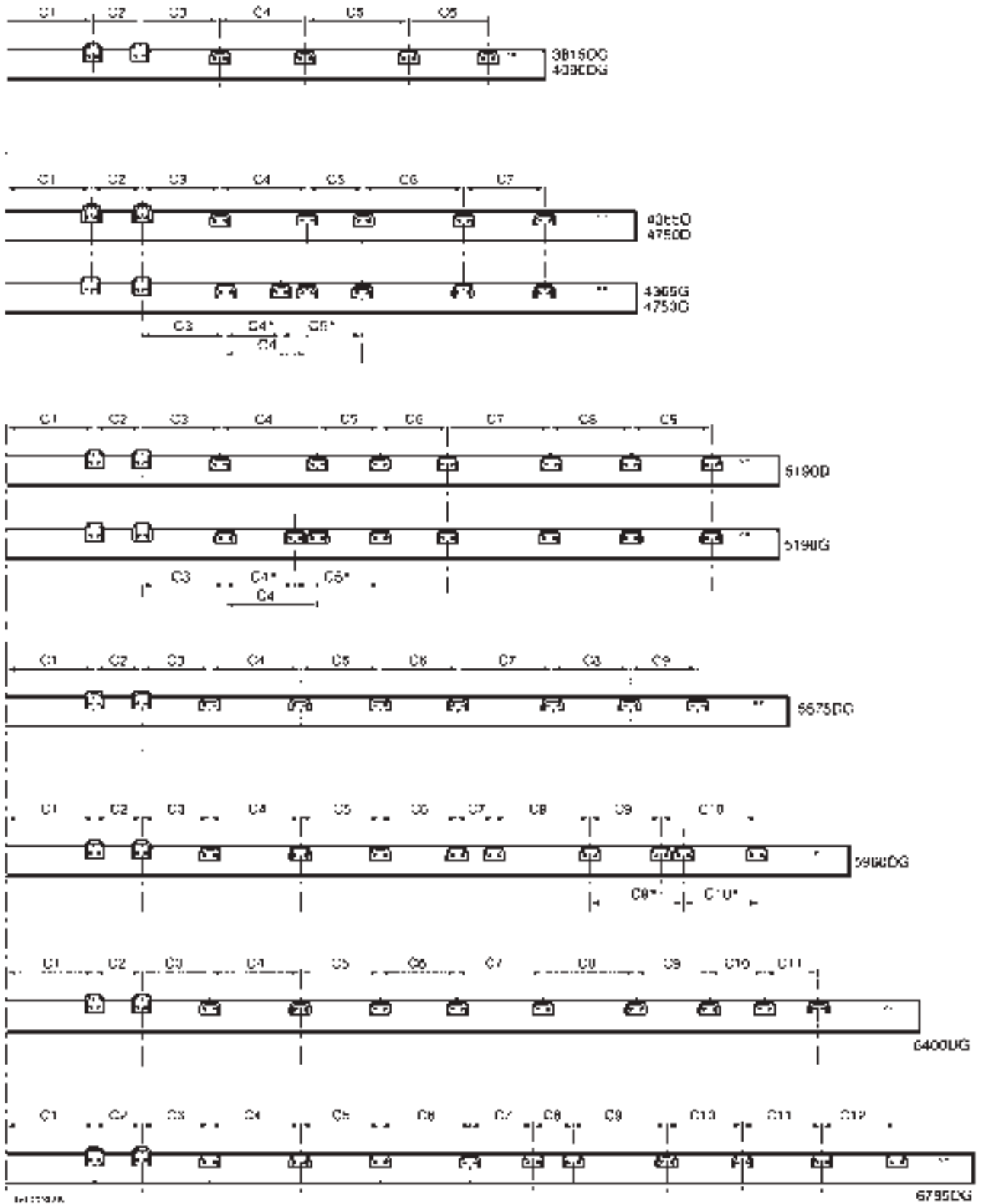

4x2 rigid - 18 tonnes, air suspension

E	L	C1	C2	C3	C4	C4*	C5	C5*	C6	C7	C8	C8*	C9	C9*	C10	C10*	C11	C12				
3815	D	885	440	742,5	825		990		770													
	G			797,5	770																	
4090	D			742,5	1100																	
	G			797,5	1045																	
4365	D			742,5	825	605	550	715	990	770	660											
	G			797,5	770																	
4750	D			742,5	935	825	825	990														
	G			797,5	880																	
5190	D			742,5	935	605	770	660	990	770					770							
	G			797,5	880																	
5575	D			742,5	935	825	825	935	990	825												
	G			797,5	880																	
5960	D			742,5	935	880	770	385	990	770					935	605	440	605				
	G			797,5	880																	
6400	D			742,5	935	825	880	990								800		660				
	G			797,5	880																	
6785	D	742,5	935			935	715	385					990		770		825	770				
	G	797,5	880																			

* With spare wheel carrier, for E = 4365, 475 and 5190 mm

** Cross-member under chassis, for E = 5575 and 5960 mm

Bodywork attachment kit

Bodywork attachment kit (all vehicles)

KIT ref. N° 50 01 839 172

4x2 rigid - 19 tonnes, air suspension

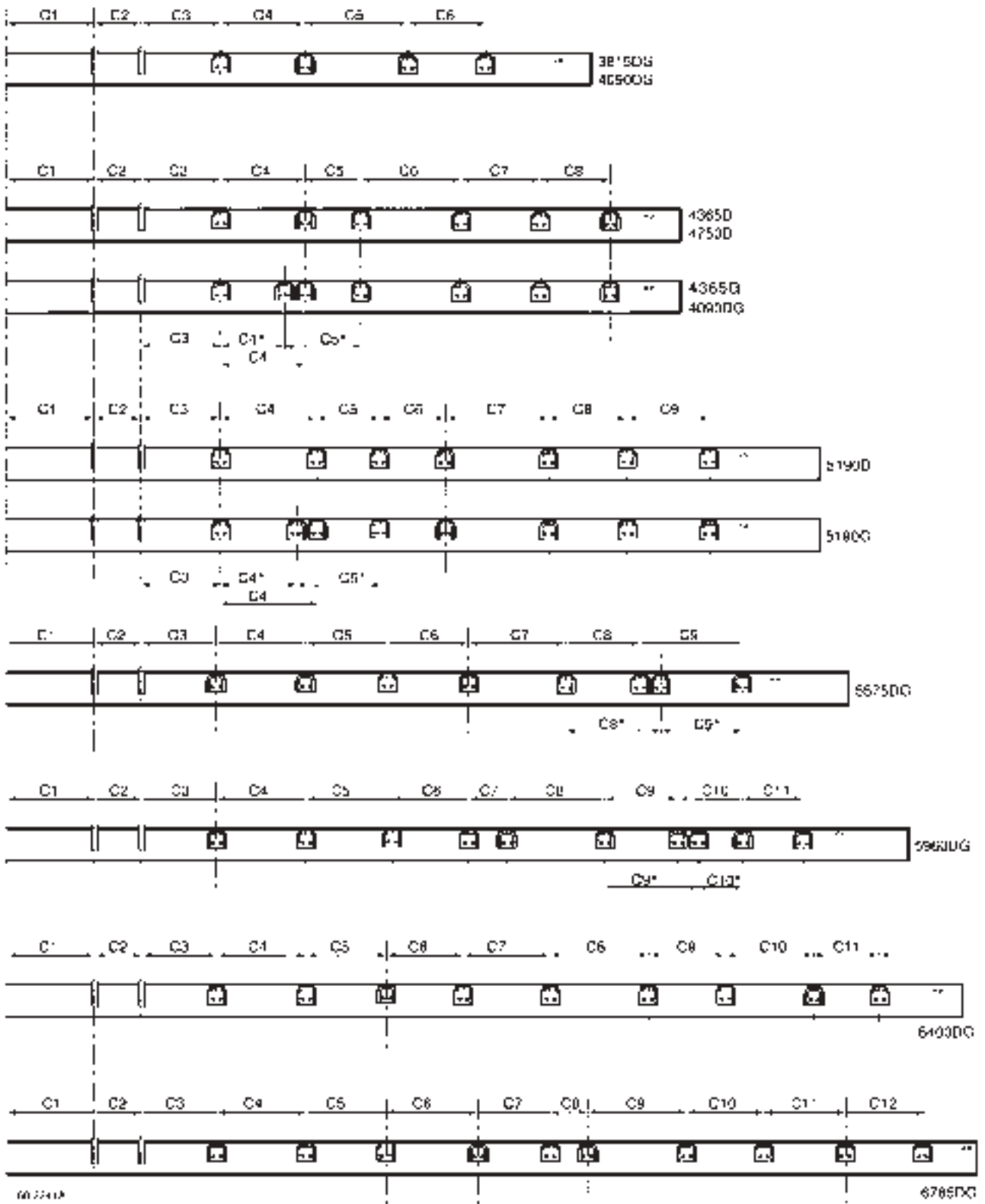

6x2 rigid - 26 tonnes, rear air suspension

E	L	C1	C2	C3	C4	C4*	C5	C5*	C6	C7	C8	C9	C10	C10*	C11	C12		
3815	D	857,5 885**	495 440**	715 742,5**	825		990		990	880	880							
	G			770 797,5**	770	550		1210										
4090	D					715 742,5**	1100		990		990	880	880					
	G			770 797,5**	1045													
4365	D					715 742,5**	825		550		990	880	880					
	G			770 797,5**	770	605	715											
4750	D					715 742,5**	935		825		990	990	935					
	G			770 797,5**	880	715	990											
5190	D					715 742,5**	935		605		660	990	880					
	G			770 797,5**	880	715	770	C9* 440		880								
5575	D					715 742,5**	935		825		825	990	880				550	
	G			770 797,5**	715	990												
5960	D					715 742,5**	935		990		770	880	990	880	770	880	880	550
	G			770 797,5**	715													
6400	D			715 742,5**	770		990		770	880	990	440			440	880		
	G	770 797,5**	715															

* Free right-hand sidemember or cross-member under chassis

** With 290 and 292 mm sidemembers (8 tonnes at front)

Bodywork attachment kit

Bodywork attachment kit (all vehicles)

KIT ref. N° 50 01 839 172

6x2 rigid - 26 tonnes, rear air suspension

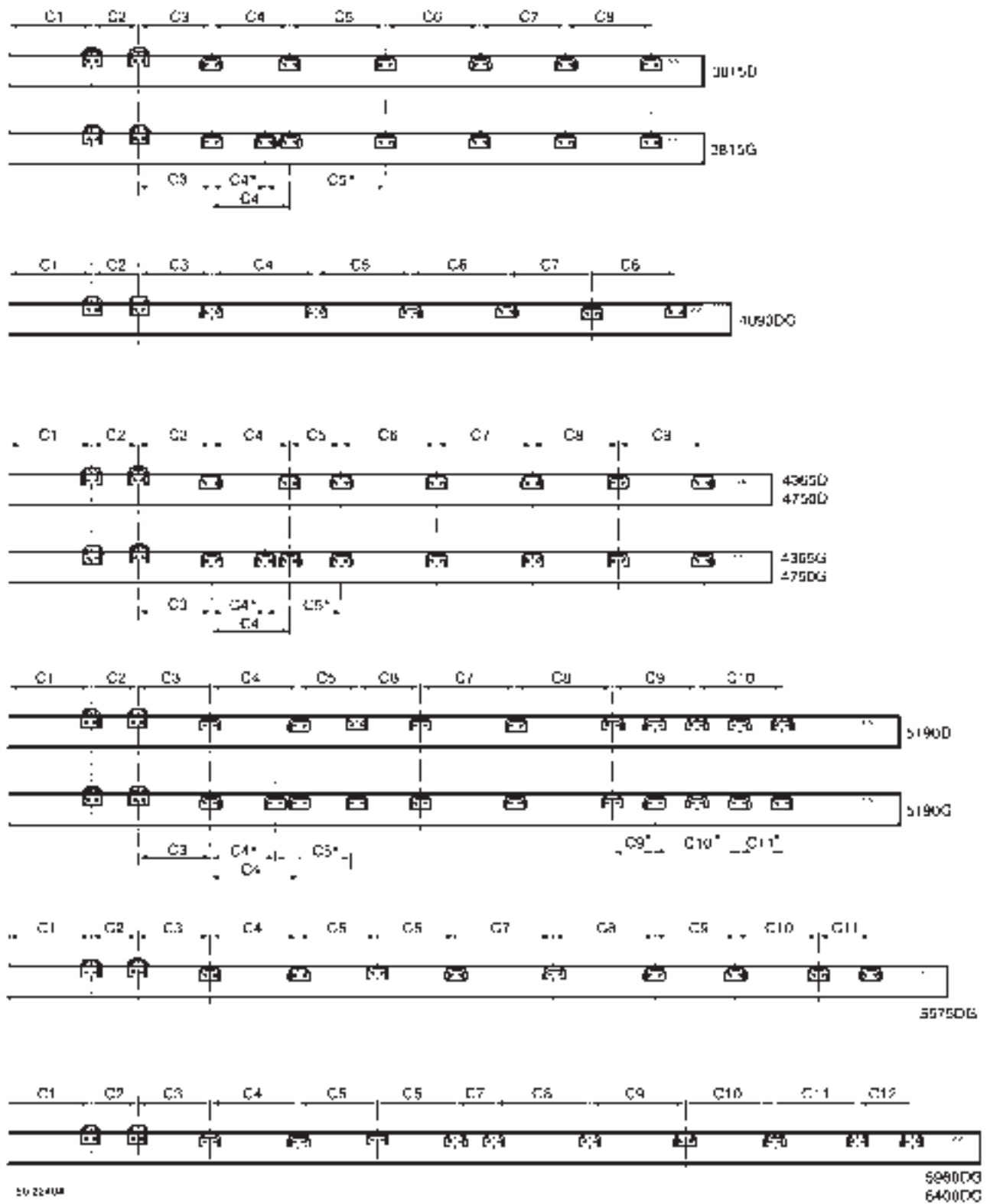

6x2/4 rigid - 26 tonnes, rear air suspension

E	L	C1	C2	C3	C4	C4*	C5	C5*	C6	C7	C8	C9		
4475	D	885	605	577,5	825		660		990					
	G		660	522,5										
4805	D		605	577,5	385		770		825	1045	660		990	770
	G		660	522,5										
5245	D		605	577,5	770		550		825	1045	660		990	770
	G		660	522,5										
5740	D		605	577,5	495		550		825	1045	660		990	770
	G		660	522,5	660		495		385	550	660		990	770

* Free right-hand sidemember or cross-member under chassis

Bodywork attachment kit

Bodywork attachment kit (all vehicles)
KIT ref. N° 50 01 839 172

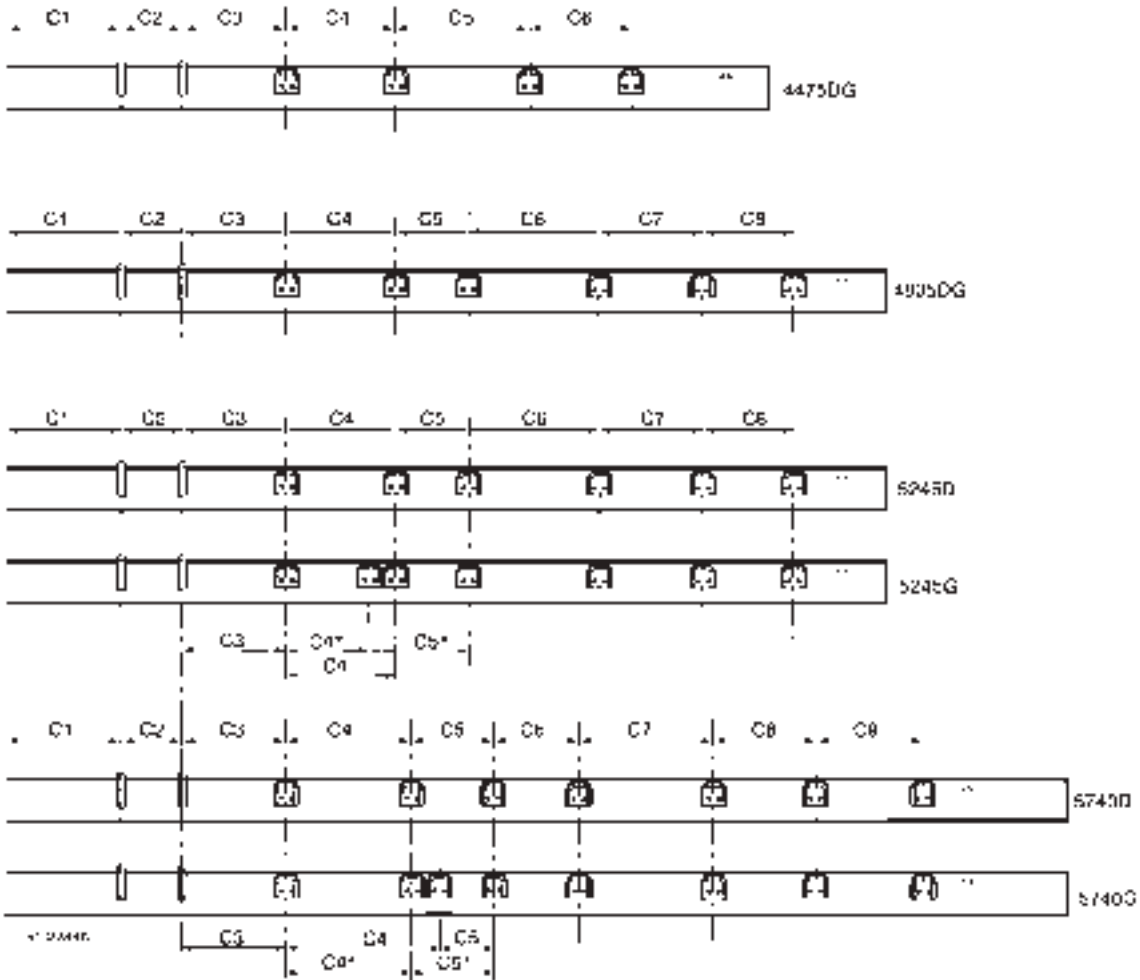

ELECTRICAL PRE-ARRANGEMENTS

4. ELECTRICAL PRE-ARRANGEMENTS

4.1 Available power supplies

The electrical pre-arrangements are necessary to obtain certain functions (e.g. special machine warning light) and contribute towards improved assembly quality for optimized cost price.

Any electrical connection must mandatorily be made to the available power supplies made available by RENAULT V.I.

It is forbidden to make an electrical tapping to the different wiring harnesses on the vehicle.

Use and adapt the connectors and wiring harnesses approved and distributed by RENAULT V.I.

The cable sections must be adapted to the required use (5 Amps per mm²).

Comply with the circuit protections recommended by RENAULT V.I.

It is forbidden to change the rating of the fuses.

4.2 Electrical pre-arrangements

Specific wiring harnesses route the power supplies and information from the warning lights and switches located in the cab as far as the battery compartment.

Make-up:

In the cab on the display

- Six pictograms integrated in the instrument panel are dedicated to the bodybuilder function:
 - pictogram (1): van interior lighting,
 - pictogram (2): equipment power supply, machine unlocking,
 - pictogram (3): tail lift in working position (coupled to stop light and triggering of buzzer if the road speed is above 5 km/h),
 - pictogram (4): chassis equipment alert (available to bodybuilder, coupled to stop light).
 - pictogram (5): sideboard open (coupled to stop light and triggering of buzzer if the road speed is above 5 km/h),
 - pictogram (6): tipper raised (coupled to stop light and triggering of buzzer if the road speed is above 5 km/h).

- Display of pictograms:
 - pictograms (1) & (2) are displayed when the corresponding switches (7) & (8) are actuated.
 - pictograms (3) & (6) are displayed when the corresponding wires are connected to earth:
 - pictogram (3): wire 651 on the black connector, on stand-by in connection unit,
 - pictogram (6): wire 8087 on the black connector, on stand-by in connection unit,
 - pictogram (4) is displayed when the wire 8084 is connected to "+" 24V.
 - pictogram (5) is displayed when the wire 8086 is connected to "+" 24V.

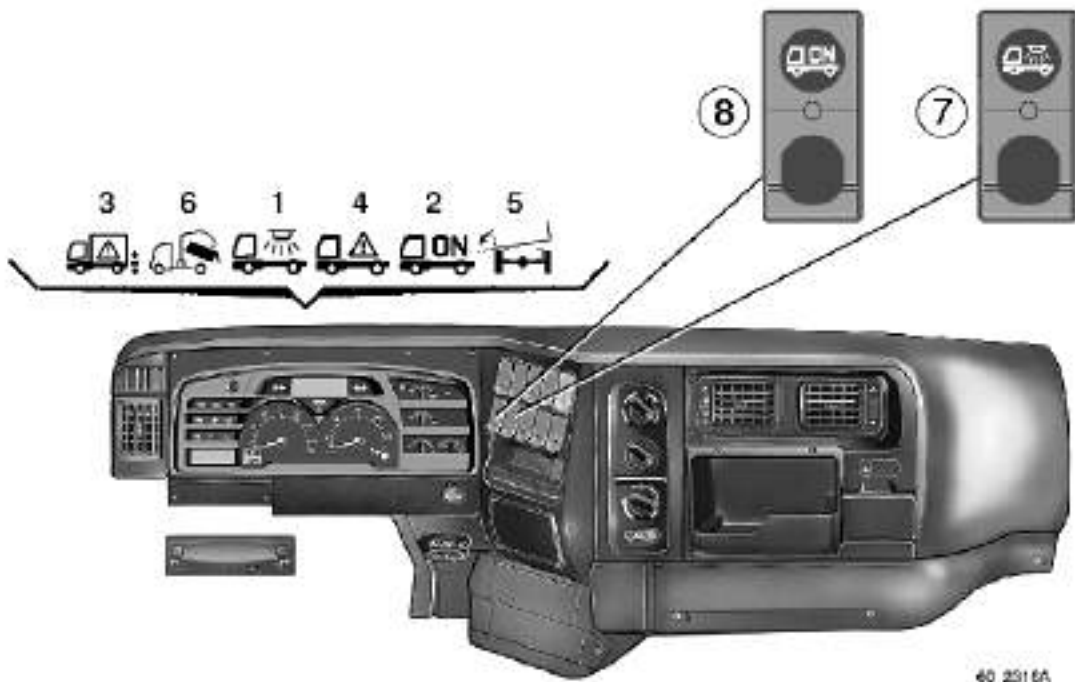
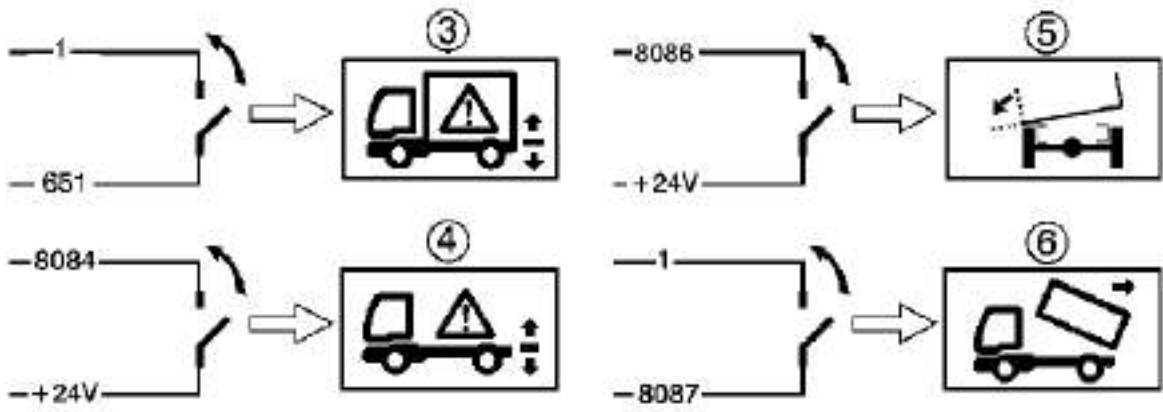

Available power supplies in the cab on connection unit

One black connector **(A)** on stand-by delivers cab available power supplies:

- wire 045: variable engine speed
- wire 047: variable engine speed
- wire 088: PTO speed
- wire 208: after master switch "+" power supply
- wire 618: chassis lighting (10A) "+" power supply, controlled by chassis lighting switch
- wire 651: pictogram **(3)** display (see preceding pages)
- wire 1025: variable engine speed
- wire 1026: PTO speed
- wire 8083: equipment "+" power supply, controlled by machine unlocking switch
- wire 8084: pictogram **(4)** display (see preceding pages)
- wire 8086: pictogram **(5)** display (see preceding pages)
- wire 8087: pictogram **(6)** display (see preceding pages)

One grey connector **(B)** on stand-by delivers cab available power supplies:

- wire 1: earth
- wire 275: after ignition "+" power supply

One grey connector **(C)** on stand-by delivers cab available power supplies:

- wire 1: earth
- wire 208: after master switch "+" power supply

Possibility of passing a wiring harness through the gap **(1)** left under the connection unit.

It is recommended to fasten the wiring harness of connector **(A)** with a Colson clamp, using the hole **(2)** located in the connector bracket angle-iron.

Available power supplies in the cab in the overhead ledge

Two wires **(D)** on stand-by deliver ledge available power supplies:

- wire 1: earth
- wire 305: marker lights power supply

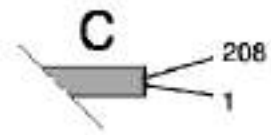
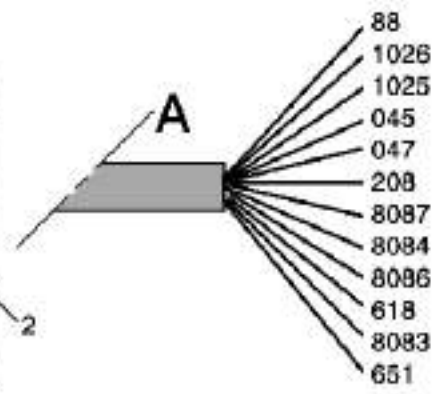
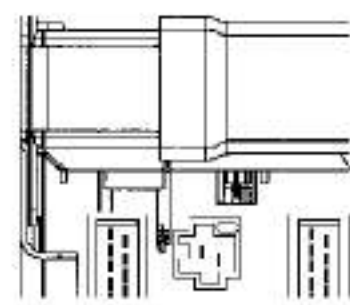
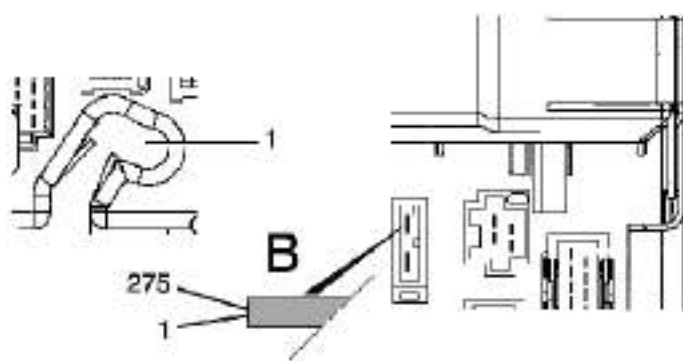
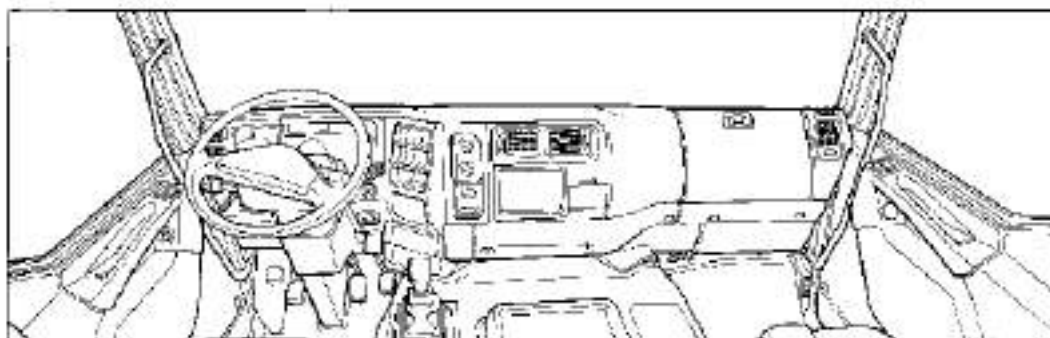
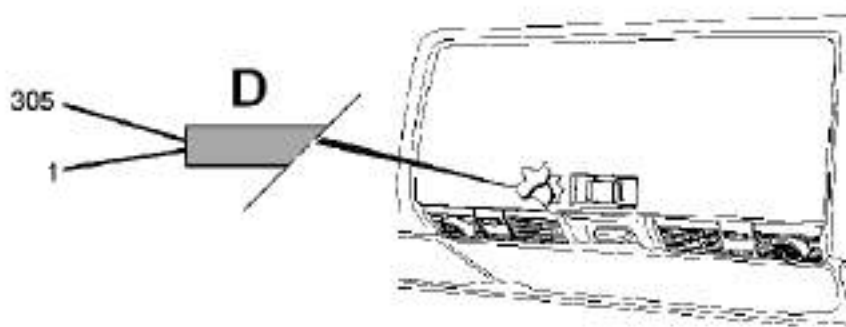

80 7310A

In the battery compartment

- Available power supplies on stand-by in the battery compartment:
- One black connector (E):
 - wire 208: after master switch "+" power supply
 - wire 275: after ignition "+" power supply
 - wire 632: side lights "+" power supply
 - wire 0403: alarm info

In the right-hand sidemember

- Two wires (F) on stand-by deliver chassis available power supplies:
- wire 1: earth
 - wire 632: side lights "+" power supply

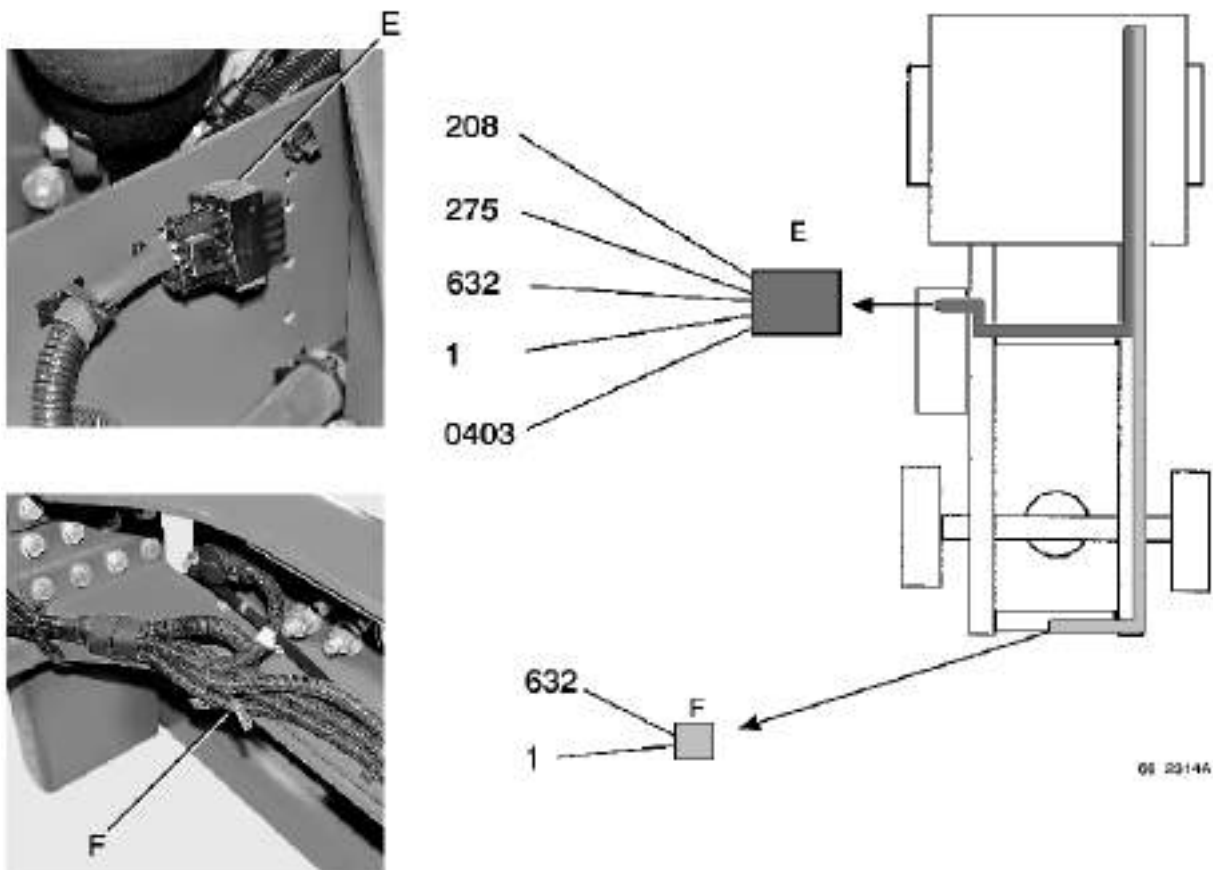

4.3 Management of engine speed

There are 2 ways of accessing the fast idling mode:

- by the steering wheel control,
- by the variable speed controls.

4.3.1 Choice of engine speed by default

When the vehicle is equipped with a power take-off, the procedure for engaging it is unchanged (see Driving handbook).

It is possible to choose between two pre-programmed speeds according to the vehicle use (see following table).

If wires 88 and 1026 are not connected, PTO speed 1 is activated.

If wires 88 and 1026 are connected, PTO speed 2 is activated.

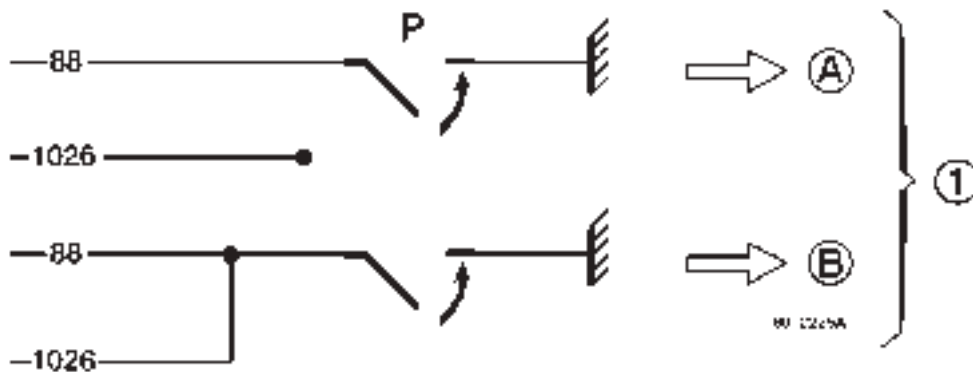

If a second PTO is mounted, its engagement must connect wire 1026 to earth to access the corresponding idling speed (PTO 2).

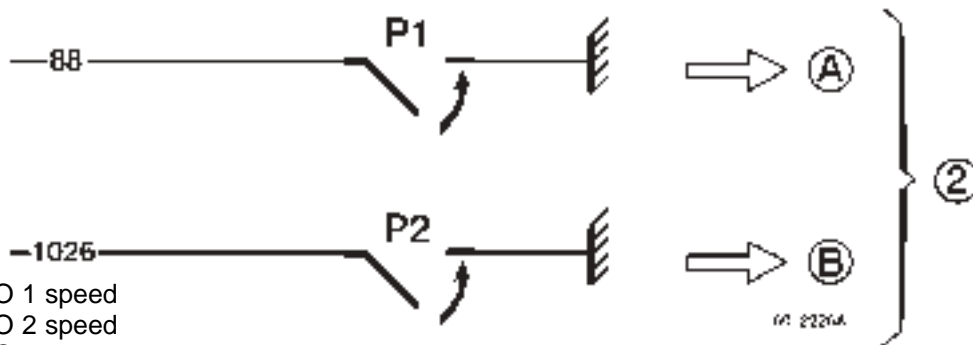

- A - PTO 1 speed
- B - PTO 2 speed
- P - PTO
- P1 - PTO 1
- P2 - PTO 2

4.3.2 Use of the steering wheel fast idling control

Move the ring (1) to the "ON" position (except refuse collectors).

To vary the idling speed, turn the ring (2) to bring "R+" or "S-" opposite the mark (3), then release it.

Depress the accelerator pedal to bring the engine to the required engine speed and in this position, turn the ring (2) to bring "S-" opposite the mark (3) so as to memorize the speed, then release it.

Release the accelerator pedal.

To fine tune the engine speed:

- Turn ring (2) to bring "R+" opposite the mark (3) to increase the speed.
- Turn ring (2) to bring "S-" opposite the mark (3) to reduce the speed.

Any action on the brake pedal or any gearshifting or moving the ring (1) to the "OFF" position overrides the feature.

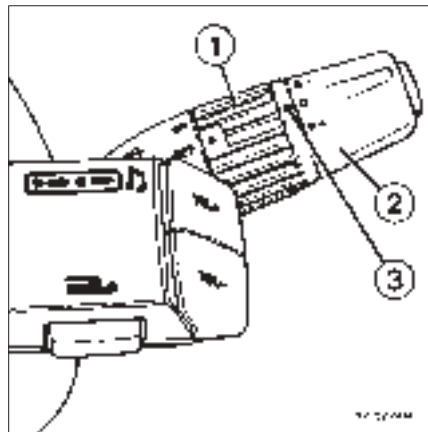

4.3.3 Vehicle fitted with a power take-off

When the PTO is in operation, move the ring (1) to the "ON" position. The first action on the ring (2) ("S-" or "R+") calls up the works set engine rotating speed (1100 rpm) (or 950 rpm for vehicles equipped with a second PTO).

Rotating speed

In the event of hydraulic pump drive, do not exceed the rotating speed indicated by the equipment manufacturer.

The engine speed is limited to 1400 rpm by the works setting.

Depending on the equipment fitted by the equipment manufacturer, this engine speed can be modified by means of the RENAULT V.I. test tool.

IMPORTANT

Avoid actuating the accelerator pedal during the use of the fast idling feature.

4.3.4 Use of the chassis-mounted fast idling control

Earthing of wire 8067 permits access to the fast idling speed from the chassis.

4.3.5 Use of the chassis-mounted fast idling variable speed control

Variable chassis-mounted speed control (example of connection)

- Install a monostable switch (1) between wires 1025 and 045.
- Install a monostable switch (2) between wires 1025 and 047.

When switch (1) is closed, the engine speed increases.

When switch (2) is closed, the engine speed decreases.

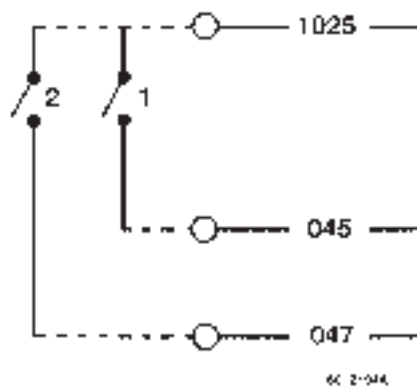

It is possible to install a 3-position monostable switch to avoid having to use the two acceleration and deceleration controls at the same time.

Upon the first pulse on one of the two controls, the engine passes to the pre-programmed speed, then the engine speed is adjusted by means of the controls.

IMPORTANT

All the chassis-mounted controls are doubled up on the steering wheel controls.

4.4 Electrical diagram for available power supplies

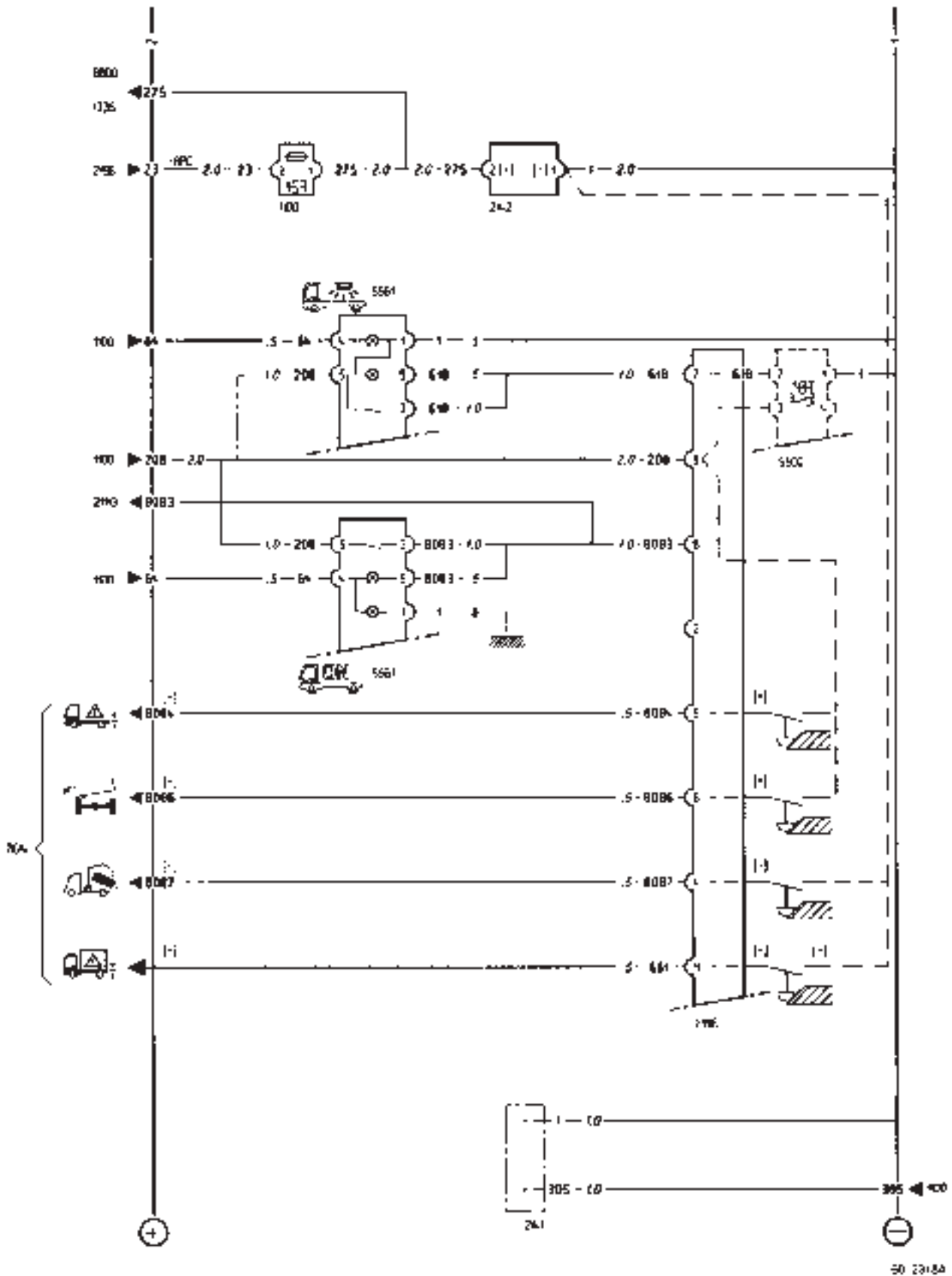

Electrical diagram for available power supplies

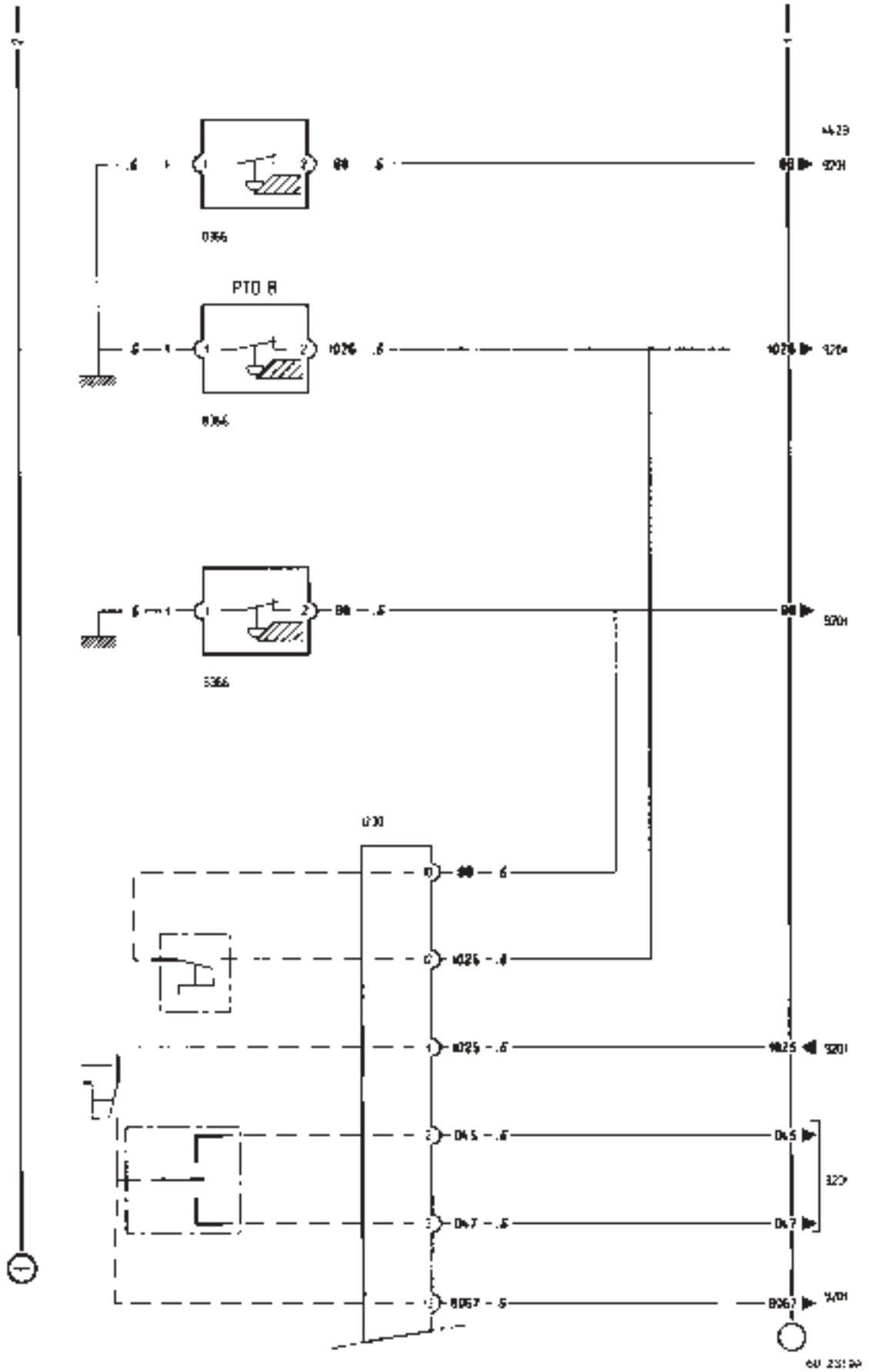

Electrical diagram for available power supplies

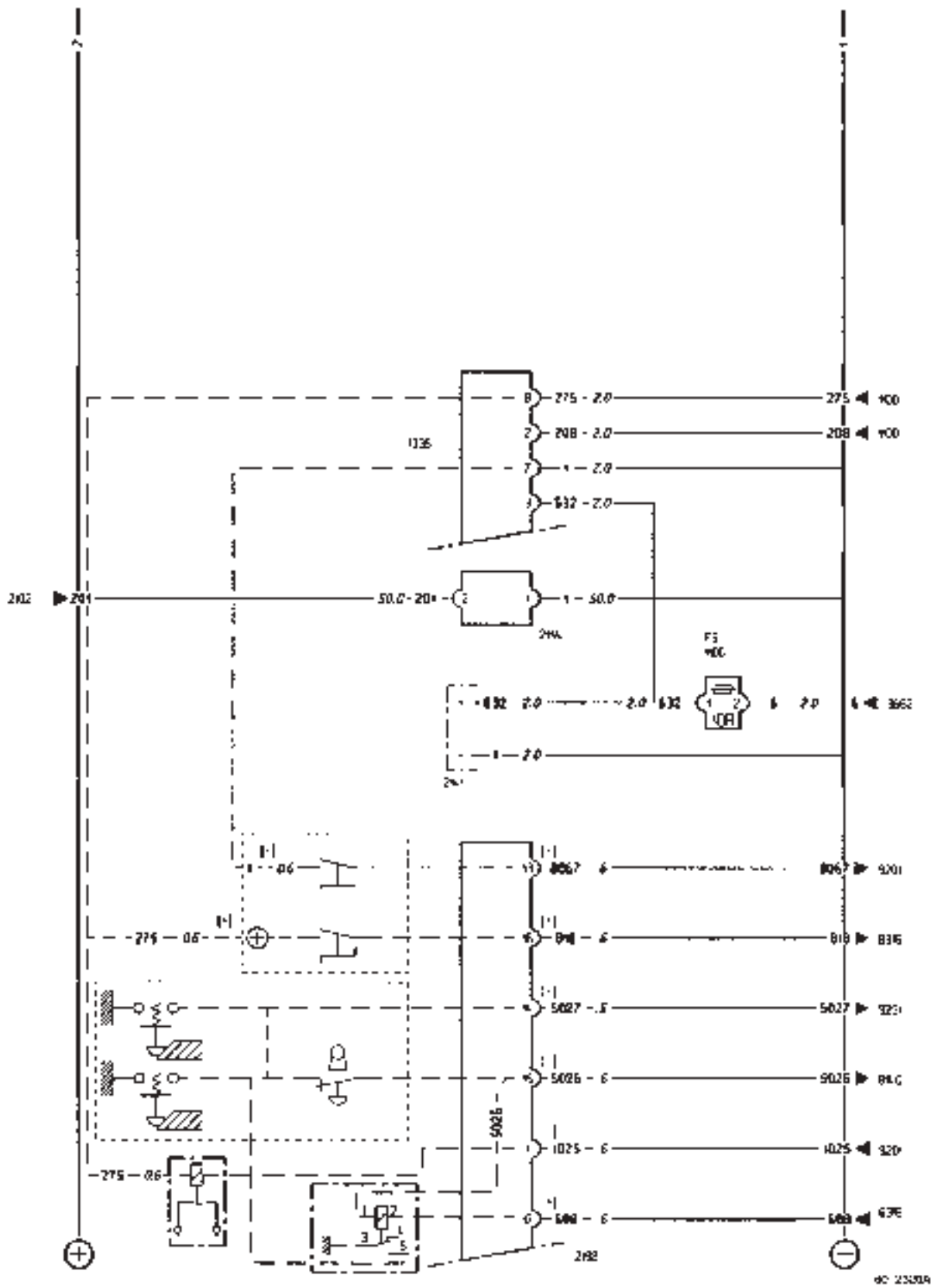

Key

1100 - Fuses
1230 - Chassis-cab connection unit
1335 - Bodybuilder available power supplies connector
2102 - Battery N° 2
2113 - Trailer socket, 7-pin type 24 N
2141 - Available power supply (lighting)
2142 - Available power supply (after key ignition)
2154 - Plug socket (150 Amps)
2196 - After ignition "+" power supply (R1)
2198 - Bodybuilder available connector
3662 - Lighting relay (R8)
4423 - Independent heater
5500 - Gate valves illumination relay
5561 - Gate valves illumination control
6316 - Reversing lights relay (R54)
7614 - Principal display
8140 - Braking circuit electrovalve (reversing safety)
8316 - Power take-off electrovalve
8366 - Power take-off switch
8800 - Air dryer
9201 - Vehicle electronic control unit (VECU)

Assignment of fuses concerning electrical pre-arrangements

Fuse	Amperage	Wire N°	Function
F3	10	305	Side lights power supply
F5	10	632	Lateral lights power supply
F6	10	64	Lighting power supply
F21	15	208	After master switch "+" power supply
F35	15	275	After ignition "+" power supply

Do not exceed the max. currents of the switches; if you do, relay the power supply.

“REFUSE COLLECTOR” VEHICLE

5. "REFUSE COLLECTOR" VEHICLE

The mounting of a continuous sub-frame is mandatory.

5.1 Longitudinal positioning of brackets on chassis

The first bracket is installed on the vehicle - the other brackets are not supplied. The dimensions indicate the position of the drilling only.

6x2/4 rigid, refuse collectors

Bodywork attachment kit

Bodywork attachment kit (all vehicles)

KIT ref. N° 50 01 839 172

* Free right-hand sidemember

E	L	C1	C2	C3	C4	C4*	C5	C5*	C6	C7	C8				
4475	D	885	605	577,5	825		660		990						
	G		660	522,5											
4805	D		605	577,5	385		770		825			1045	660	990	
	G		660	522,5											
5245	D		605	577,5	770		550		825			1045	660	990	
	G		660	522,5											
5740	D		605	577,5	495		495		385			550	1045	660	990
	G		660	522,5	660										

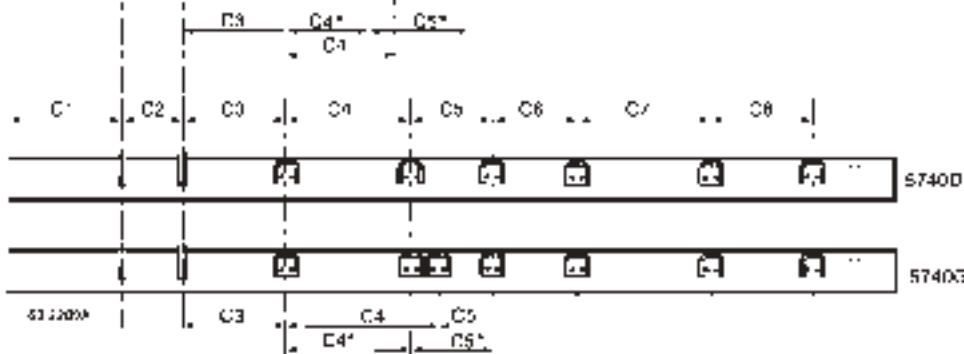
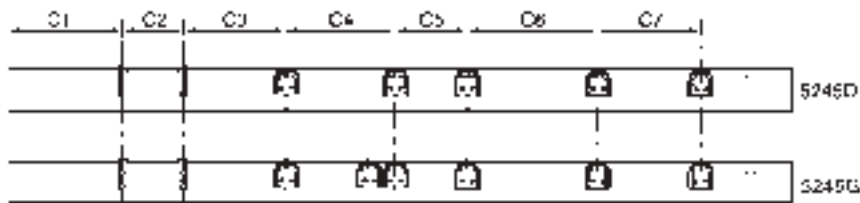
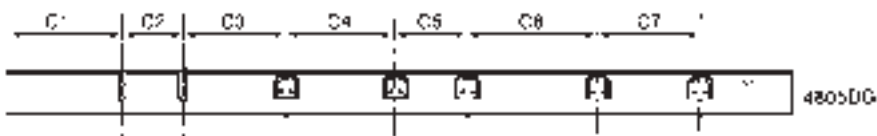
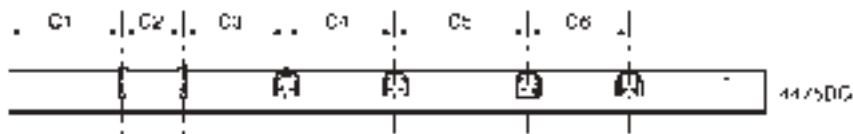

6x2/4 rigid, rear steer axle

E	L	C1	C2	C3	C4	C4*	C5	C5*	C6	C7	C8	C9	C10	C10*	C11	C12
3815	D	857,5	495	715	825		990		990	880	880					
	G			770	770	550		1210								
4090	D			715	1100			550								
	G			770	1045											
4365	D			715	825		550	715								
	G			770	770											

Bodywork attachment kit

Bodywork attachment kit (all vehicles)
 KIT ref. N° 50 01 839 172

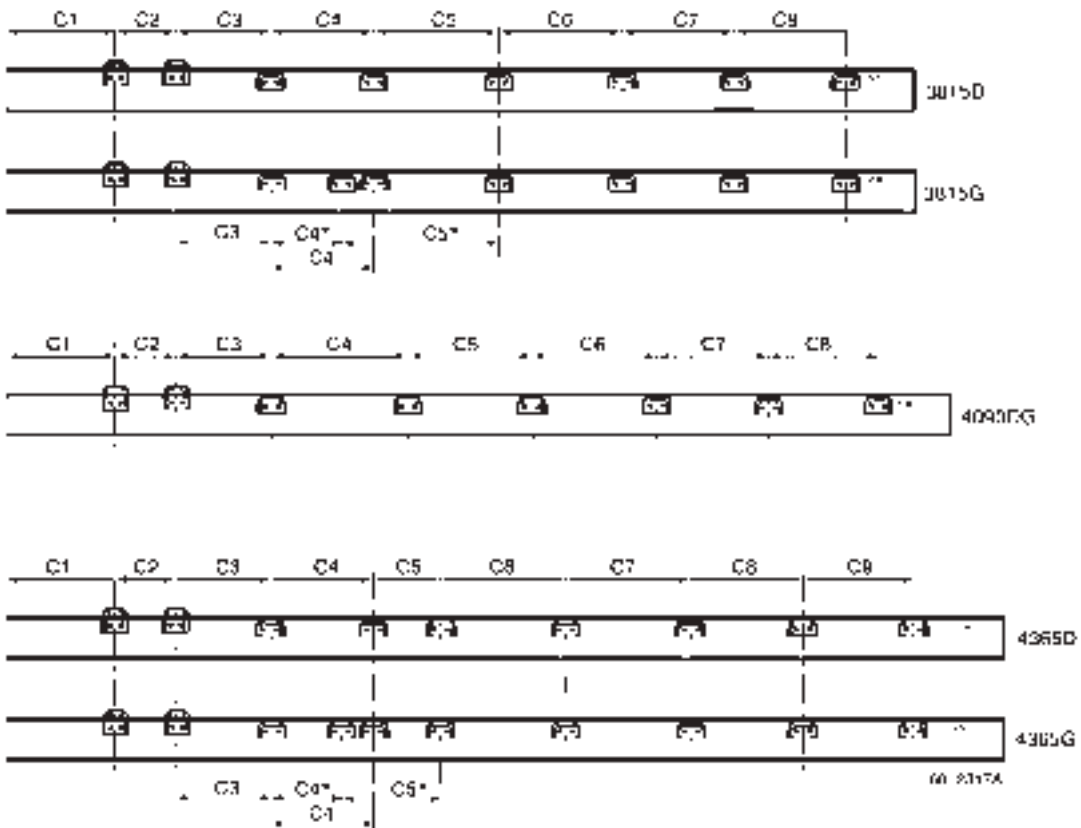

5.2 Available power supplies in cab on connection unit

One black connector (A) on stand-by delivers cab available power supplies:

- wire 045: variable engine speed
- wire 047: variable engine speed
- wire 088: PTO speed
- wire 208: after master switch "+" power supply
- wire 608: reversing safety
- wire 618: chassis lighting (10A) "+" power supply, controlled by chassis lighting switch
- wire 651: pictogram (3) display (see preceding pages)
- wire 818: PTO control "+" power supply
- wire 1025: variable engine speed
- wire 1026: PTO speed
- wire 5026: reversing safety
- wire 5027: speed limitation (30 km/h)
- wire 8067: fast idling control
- wire 8083: equipment "+" power supply, controlled by machine unlocking switch
- wire 8084: pictogram (4) display (see preceding pages)
- wire 8086: pictogram (5) display (see preceding pages)
- wire 8087: pictogram (6) display (see preceding pages)

It is recommended to fasten the wiring harness of connector (A) with a Colson clamp, using the hole (1) located in the connector bracket angle-iron.

All the other available power supplies are identical to those detailed in chapter 4.

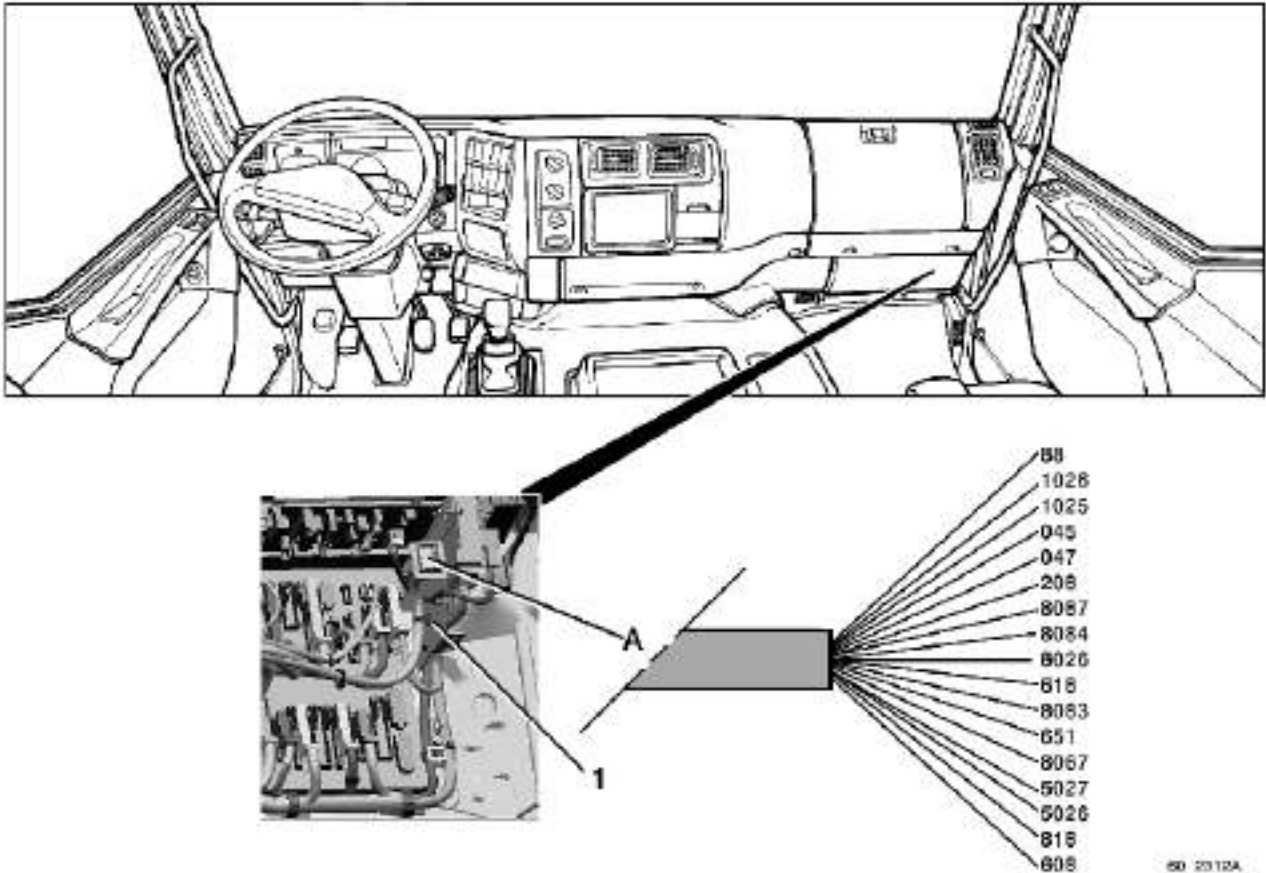

Key

- 1100 - Fuses
- 1335 - Bodybuilder available power supplies connector
- 2102 - Battery N° 2
- 2141 - Available power supply (lighting)
- 2154 - Plug socket (150 Amps)
- 2198 - Bodybuilder available connector
- 3662 - Lighting relay (R8)
- 6316 - Reversing lights relay (R54)
- 8140 - Braking circuit electrovalve (reversing safety)
- 8316 - Power take-off electrovalve
- 9201 - Vehicle electronic control unit (VECU)

Assignment of fuses concerning electrical pre-arrangements

Fuse	Amperage	Wire N°	Function
F5	10	632	Side lights power supply
F21	15	208	After master switch "+" power supply
F35	15	275	After ignition "+" power supply

Do not exceed the max. currents of the switches; if you do, relay the power supply.

“CRANES”

6. HANDLING CRANES

6.1 Handling crane with lifting torque outside graph limits

- The mounting of a one-piece sub-frame from the back of the cab to the rear extremity of the chassis, with bevelled cut-out at the front, is compulsory.
- The mounting of 4 stabilizers on the sub-frame is mandatory.
- The resistance of the sub-frame shall be determined by the installer according to the lifting capacity of the crane.
- The sub-frame for the crane shall be fastened to the sidemembers of the rigid vehicle according to our recommendations using brackets provided as standard.

6.2 Handling crane in rear overhang

- The principle of fastening by plate is recommended.
- The dimensions of the plates are to be determined by the installer according to the spacing of the crane frames.
- Fastenings (number and diameter of bolts) shall be at least those defined for the behind-cab handling crane.
- Drillings are to be made as per recommendations (see chapter B-2).

6.3 Plate mounting recommendations

- The mounting of rear plates requires checking of conformity to regulations of the position of parking/side lights and side impact beams.

Left-hand side

- Chock the rear flange.
- Unlock the silencer bracket to avoid stress between silencer and exhaust pipe.
- Push the silencer back by 10 mm and tighten to the recommended torque loadings.

Right-hand side

- Retract the filter bracket cradle by 70 mm (holes to be drilled if not existing) and the right-hand side panel lock bracket.
- Modify the routing of the fuel pipes (if prefilter and/or independent heater pump fitted).

6.4 RENAULT PREMIUM behind-cab handling crane

Crane bracket attachment

- Sidemember LH side

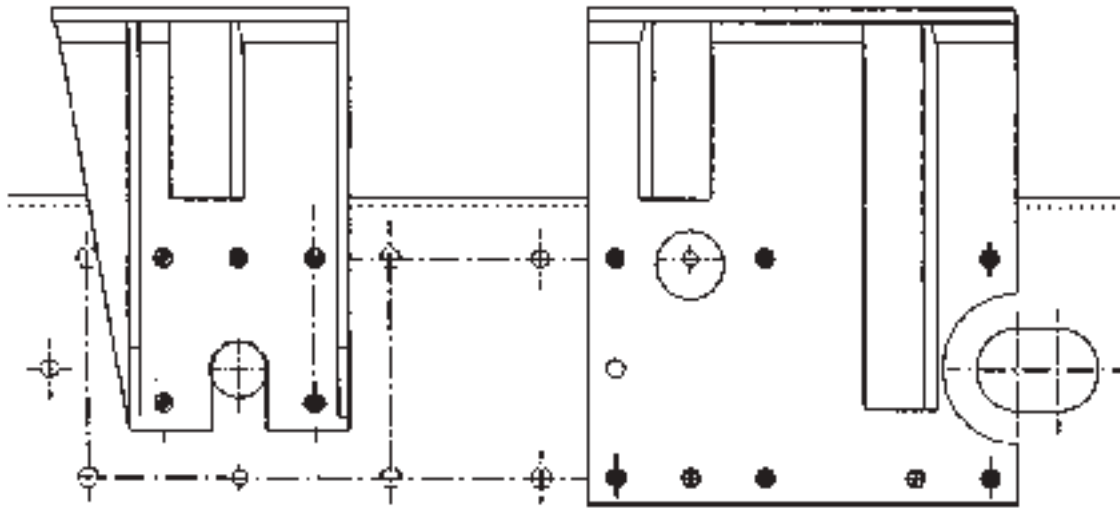

- Sidemember RH side

RD 1254

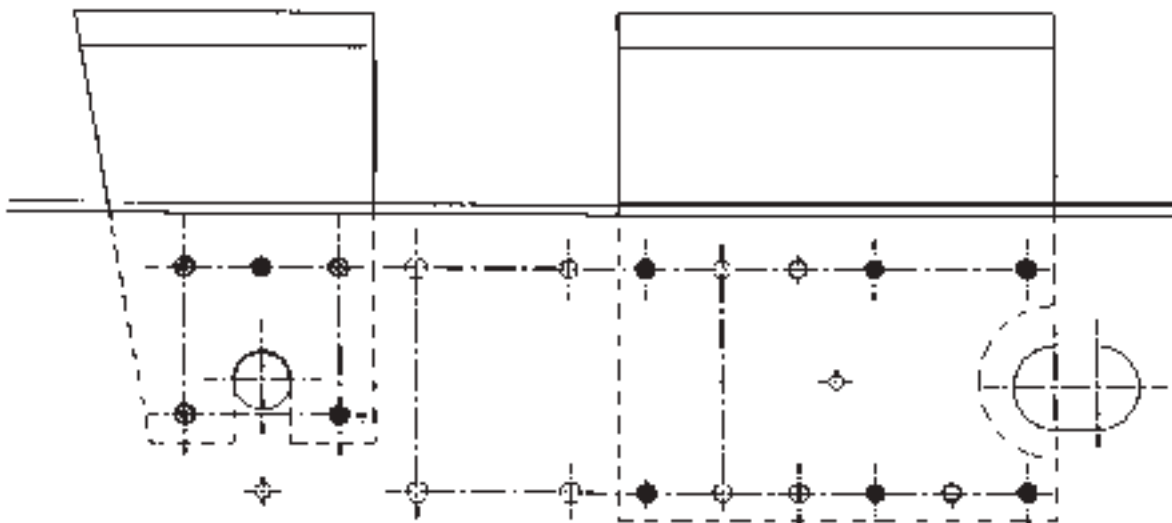

RD 1255

- For low module sidemembers (H 258/260), the crane lifting torque is limited to **11 tonnes/metre**.
- For high module sidemembers (H 290/292), the crane lifting torque is limited to **17 tonnes/metre**.

The black holes are existing holes.
Holes with a cross are holes to be drilled.

RIGHT-HAND FRONT BRACKET

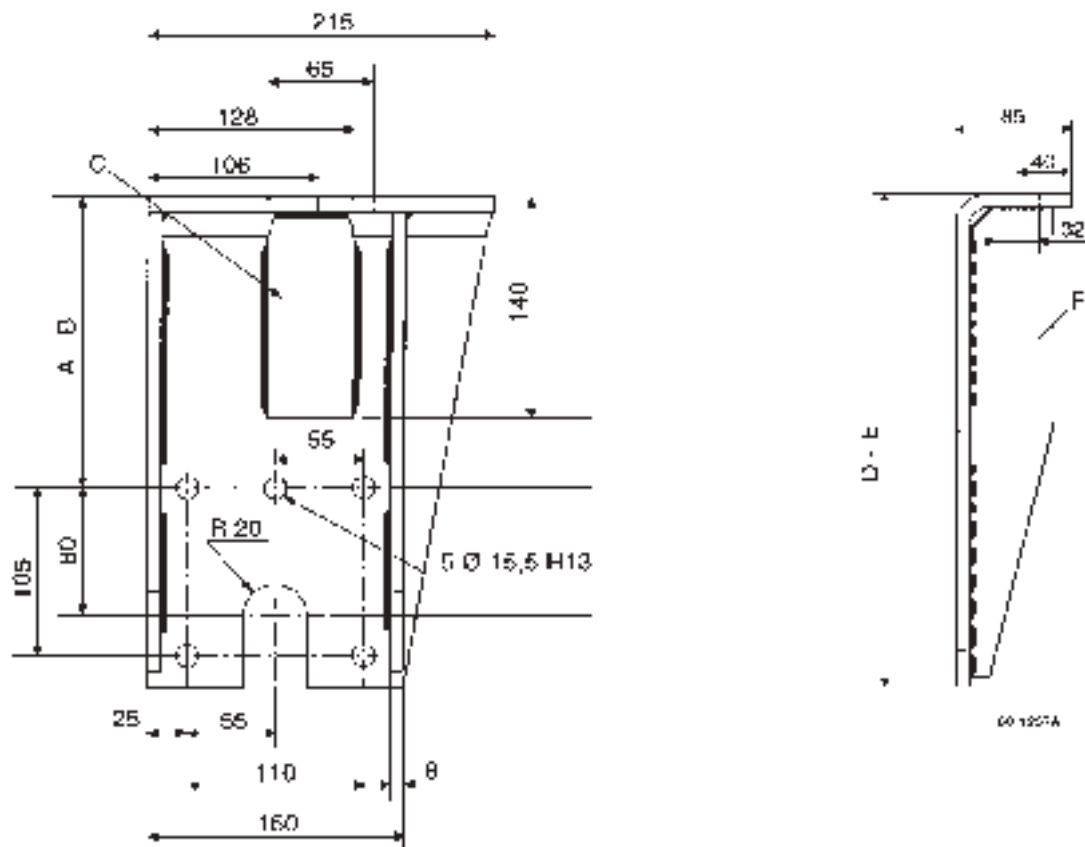

For a sub-frame 140 x 70 x 7

- A - For 258 mm sidemember = 183 mm
- B - For 290 mm sidemember = 215 mm
- C - Spacer 1
- D - For 258 mm sidemember = 308 mm
- E - For 290 mm sidemember = 340 mm
- F - Stiffener

LEFT-HAND REAR BRACKET

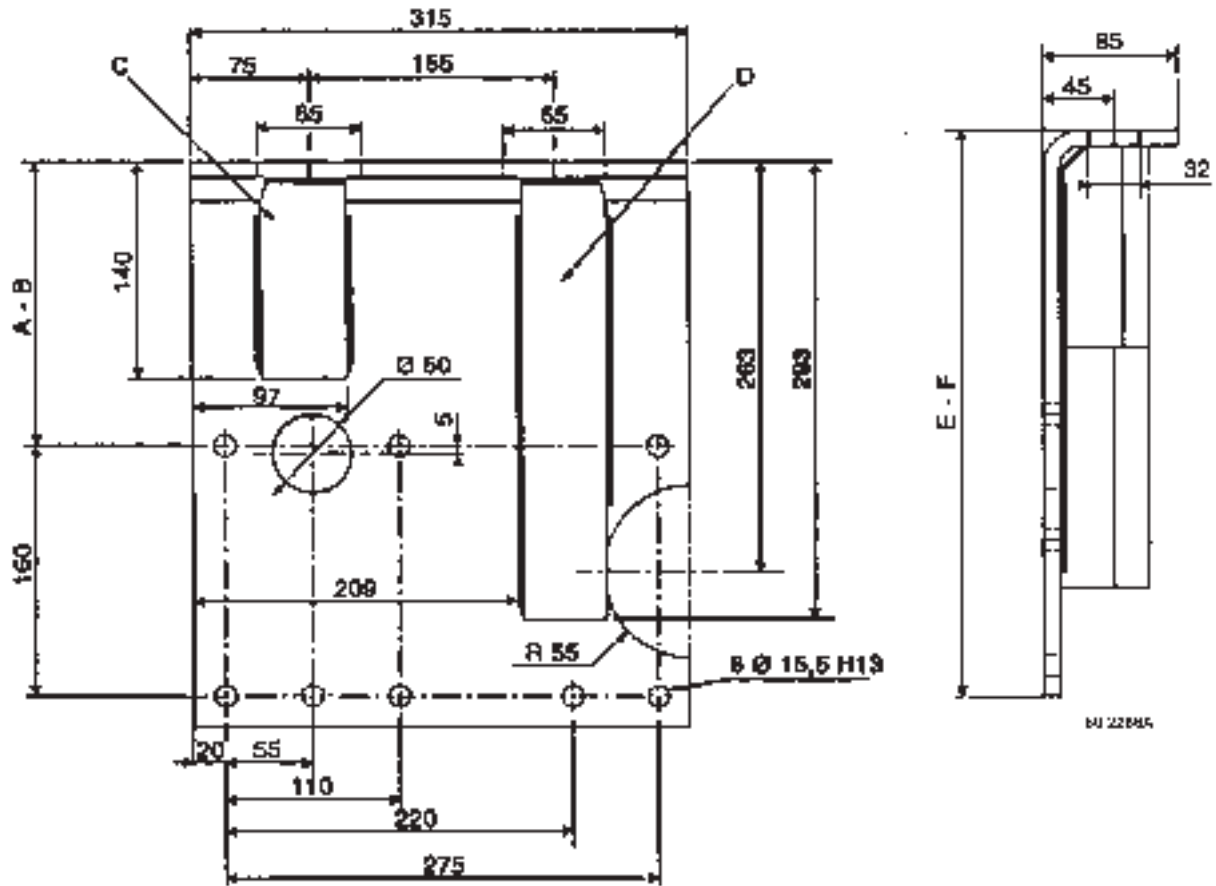

- A - For 258 mm sidemember = 183 mm
- B - For 290 mm sidemember = 215 mm
- C - Spacer 1
- D - Spacer 2
- E - For 258 mm sidemember = 363 mm
- F - For 290 mm sidemember = 395 mm

RIGHT-HAND REAR BRACKET

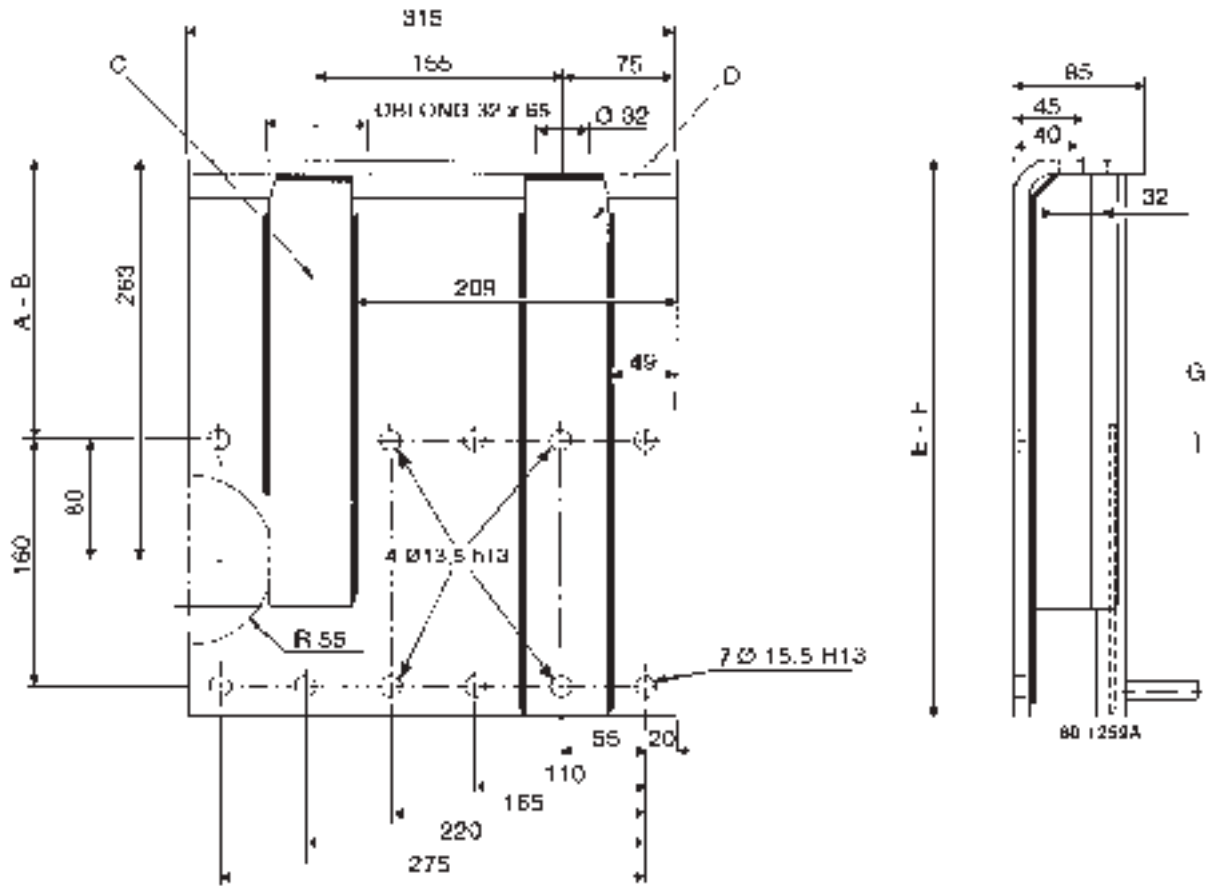

- A - For 258 mm sidemember = 183 mm
- B - For 290 mm sidemember = 215 mm
- C - Spacer 2
- D - Spacer 3
- E - For 258 mm sidemember = 363 mm
- F - For 290 mm sidemember = 395 mm
- G - Bolt support strip

MOUNTING PLATE

Sidemember LH side

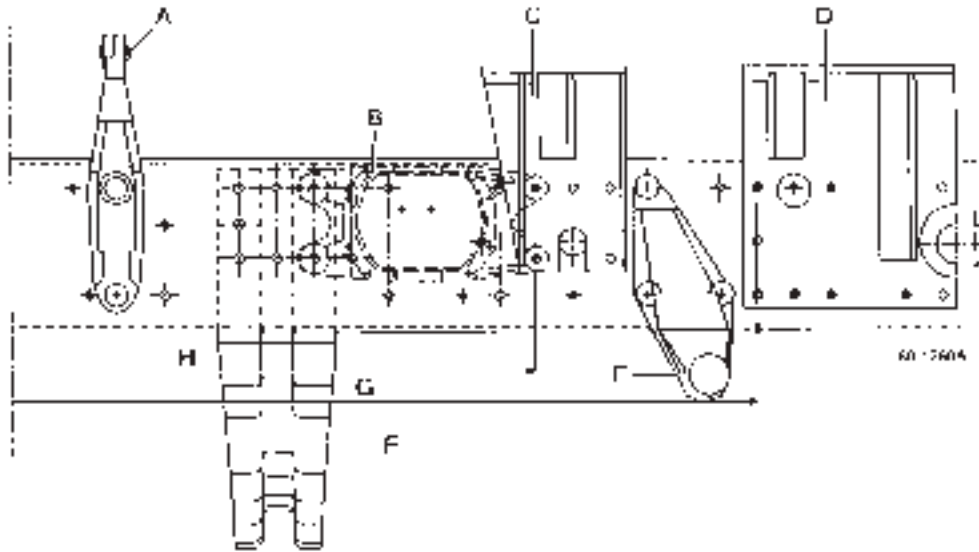

- A - Day cab rear fitting
- B - Engine bracket
- C - LH front fastening plate
- D - LH rear fastening plate
- E - Spring hanger N° 2
- F - Engine cross-member
- G - Axle centre-line to sidemember mark = 1105 mm
- H - Axle centre-line to sidemember mark = 775 mm

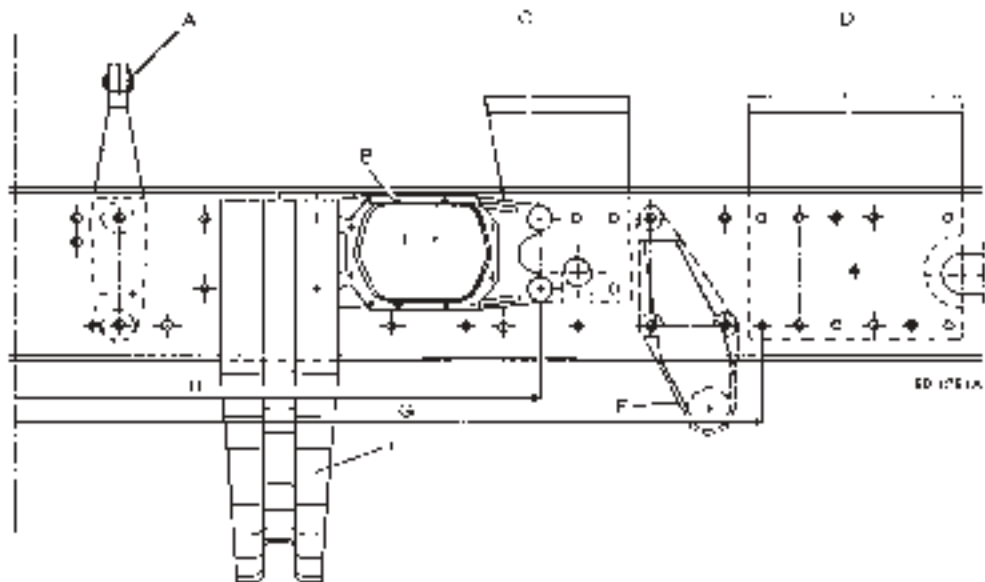

- A - Day cab rear fitting
- B - Engine bracket
- C - RH front fastening plate
- D - RH rear fastening plate
- E - Spring hanger N° 2
- F - Engine cross-member
- G - Axle centre-line to sidemember mark = 1105 mm
- H - Axle centre-line to sidemember mark = 775 mm

STIFFENER (Sheet steel E24-2 thickness 8 mm)

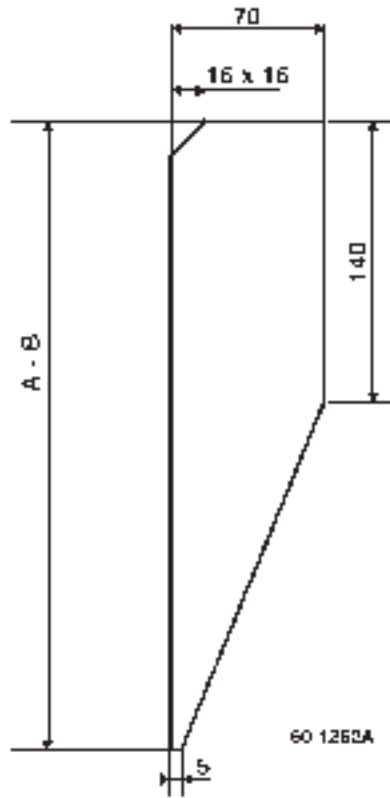

A - For 258/260 mm sidemember = 288 mm
 B - For 290/292 mm sidemember = 320 mm

SPACER 1 (Sheet steel E24-2 thickness 6 mm)

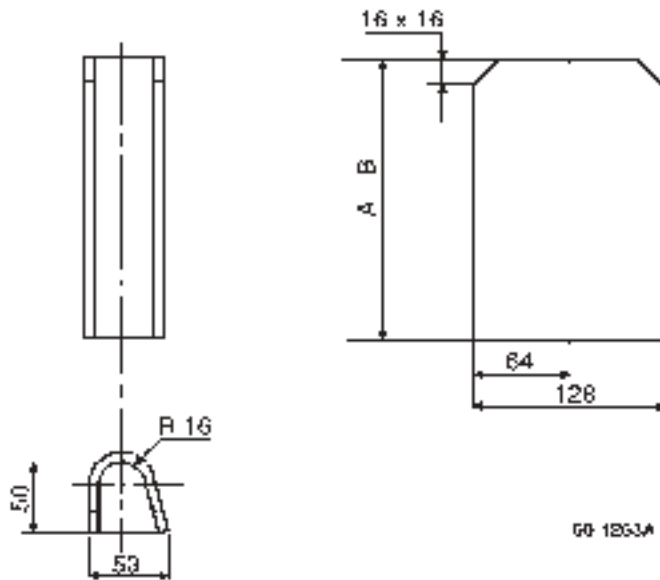

A - For 258/260 mm sidemember = 130 mm
 B - For 290/292 mm sidemember = 162 mm

SPACER 2 (Sheet steel E24-2 thickness 6 mm)

RH piece
Symmetrical LH piece

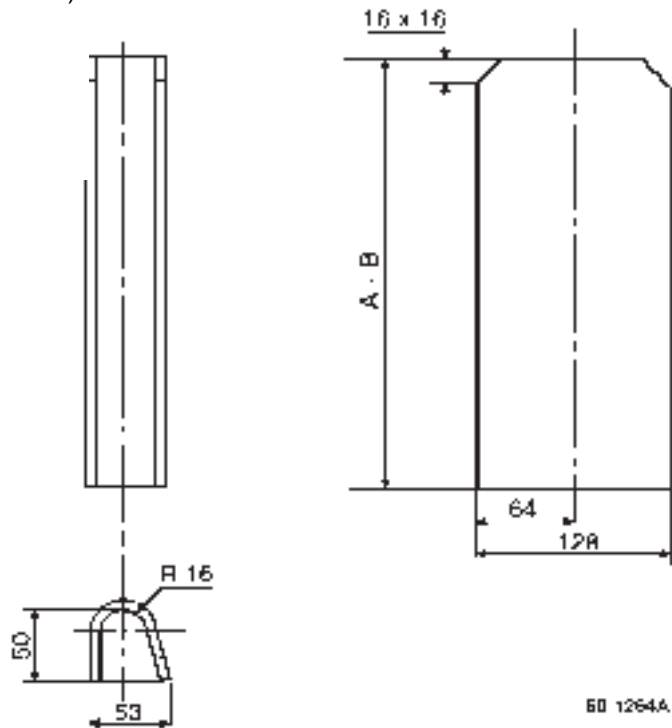

A - For 258/260 mm sidemember = 283 mm
B - For 290/292 mm sidemember = 315 mm

SPACER 3 (Sheet steel E24-2 thickness 6 mm)

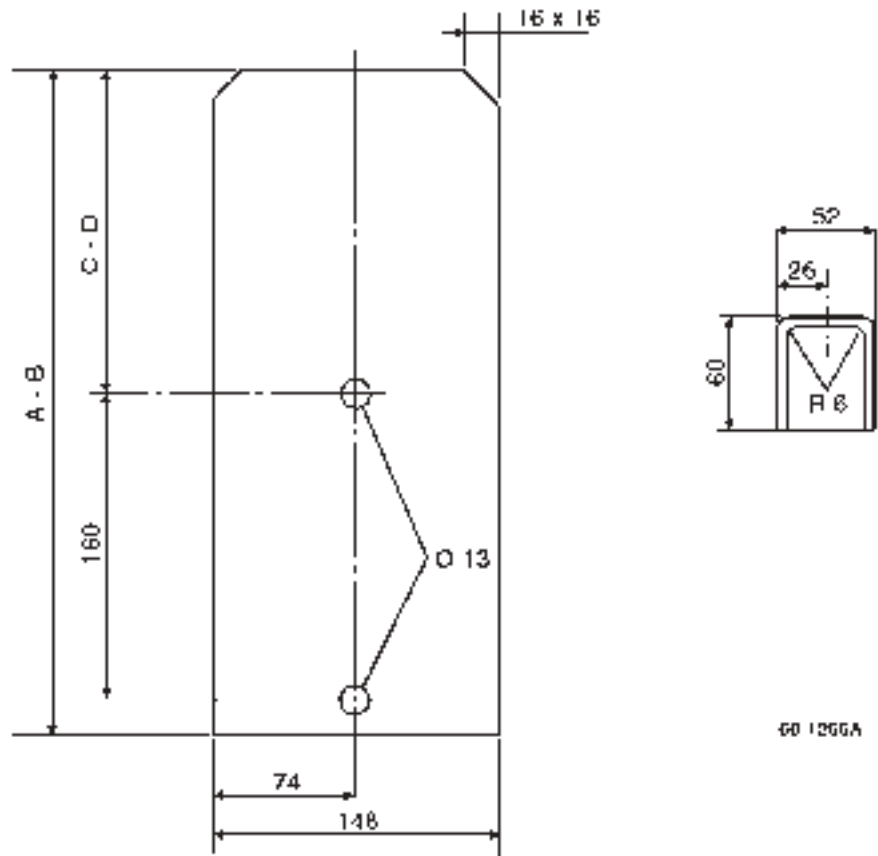

A - For 258 mm sidemember = 352 mm
B - For 290 mm sidemember = 384 mm
C - For 258 mm sidemember = 172 mm
D - For 290 mm sidemember = 204 mm

BOLT SUPPORT STRIP

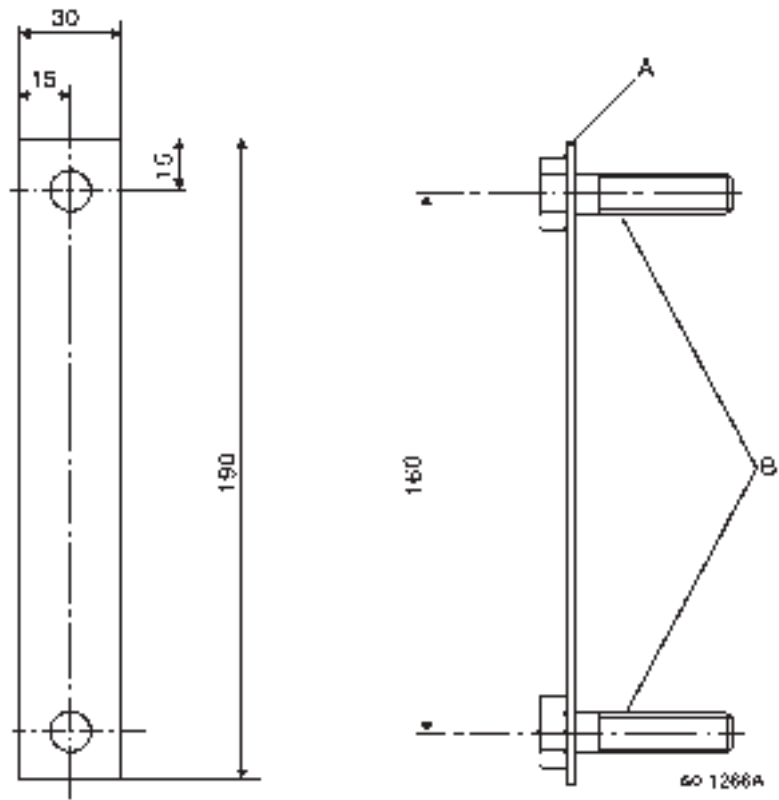

- A - Sheet steel E24-2 thickness 3 mm
- B - Bolt HM 12 x 125 length 50 class 10.9

“TIPPERS”

7. TIPPERS

On the RENAULT PREMIUM 4x2 Long Distance and Distribution series, only transporter type tippers are permitted.

RENAULT PREMIUM standard transporter tippers

The recommendations concerning sub-frames and their attachment to the vehicle chassis are identical to those defined in chapter B-27 to 37.

RENAULT PREMIUM two-way tipper and demountable tipper

- The recommendations concerning sub-frames and their attachment to the vehicle chassis are identical to those defined in chapter B-27 to 37 in the guiding and elastic fastening zone.
For the guiding and rigid fastening zone, it is permitted to use link-up plates positioned in the place of the original body brackets.
- In all cases, the rear attachment is to be made using a plate fastened by two rows of nuts and bolts Ø 14 mm.

RENAULT PREMIUM 6x2 demountable tipper

- A tipper body weighing around 15,000 kg can be picked up from the ground without risk on condition that the air suspension is in the "down" position and the lift-up axle wheels are firmly on the ground.
- Under these conditions, the vehicle remains stable, with the front axle wheels firmly on the ground, and steerability is assured.
- The maximum permissible static load on the rearmost axle with wheels firmly on the ground is 18 tonnes with single or twin tyre fitment.

“TANKERS”

8. TANKERS

Tanker (water, hydrocarbons, foodstuffs, sewer cleaner)

- The recommendations concerning sub-frames and their attachment to the vehicle chassis are identical to those defined in chapter B-27 to 37.
- The assembly of rubber sandwich mountings in the guiding and fastening zone is permitted. Their characteristics are to be equivalent to those of the recommended mechanical system.
- In the case where the layout of side-mounted accessories (e.g. pumps) does not allow the vehicle body brackets to be used, fastening by plate is permitted in the guiding and fastening zone.

PREMIUM ADR plate

- Bracket fastening (1).

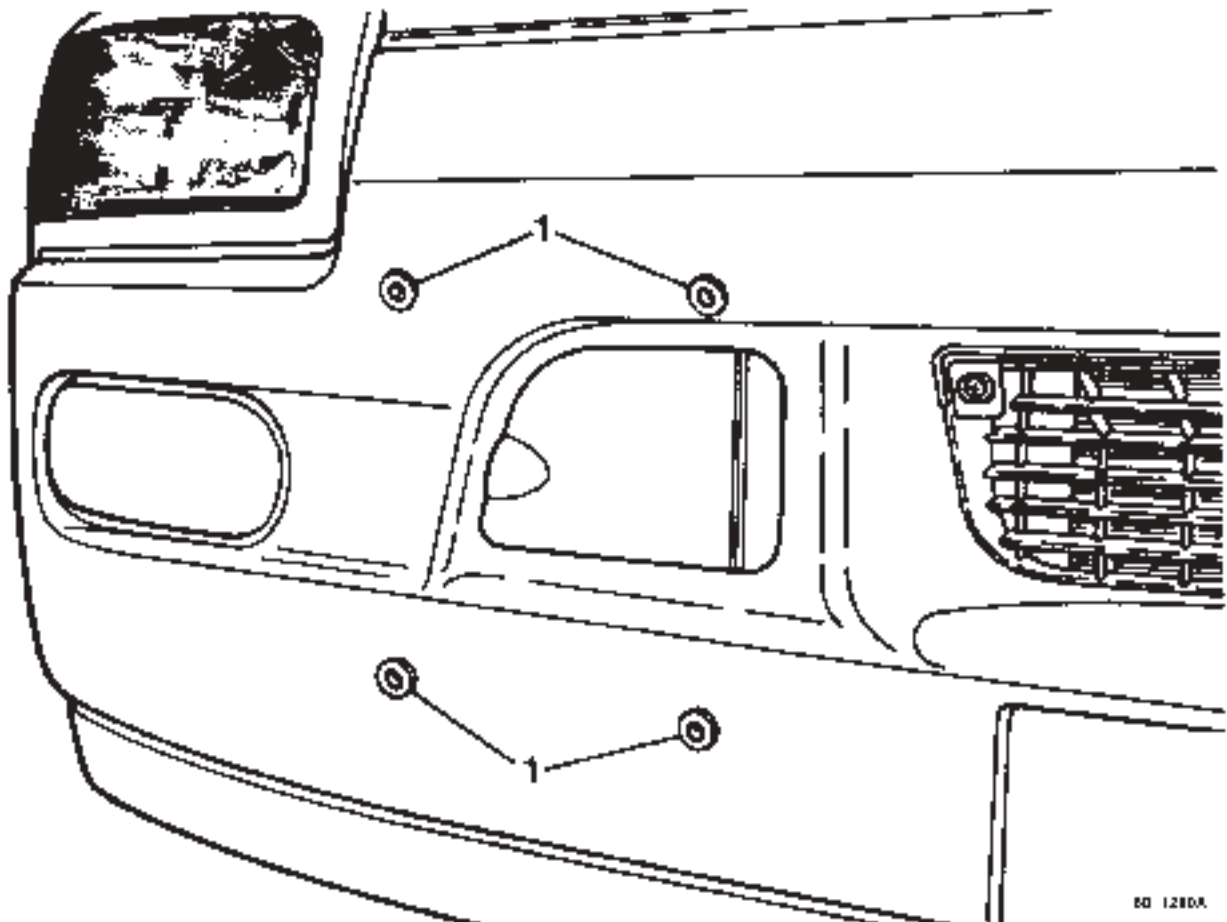

**CHAPTER -C-
SUPPLEMENTARY INFORMATION
ON THE “RENAULT PREMIUM” VEHICLE**

1. MOUNTING OF POWER TAKE-OFFS

1.1 Mechanical receiver

To install a mechanical receiver, two layouts are possible:

- on gearbox-mounted PTO,
- on engine flywheel-mounted PTO.

1.1.1 Gearbox-mounted PTO

Table of possible gearbox-mounted PTO assemblies

Power take-off	Gearbox								
	ZF 8S 151	ZF 9S 109	ZF 16S 109	ZF 16S 151	ZF 16S 181	ZF 12AS 2301 DD	EATON 5206 A	EATON 8309 A	ALLISON MD 3060
ZF NH 1B/C	X	X	X	X	X				
ZF NH 4B/C	X	X	X	X	X				
ZF NL 1C *	X			X	X				
ZF NL 4C	X			X	X				
ZF N221-10.B/C *	X			X	X				
HYDROCAR 2264 B/C							X	X	
HYDROCAR 2266 B/C							X	X	
AS 10 B						X			
HYDROCAR 17 AX									X

* The sum of the torques of the two PTOs mounted on the adaptation shaft should not exceed 1000 Nm.

NOTE

The letter "B" or "C" added after the PTO type indicates the type of coupling mounted on the PTO output:

B - flange

C - splined shaft.

PTO characteristics

Type	Maximum output torque (Nm)	Direction of rotation	Weight (kg)
ZF NH 1B/C *	1000	opposite that of engine	5/3
ZF NH 4B/C **	430	same as engine	7,5/5,5
ZF NL1C *	600	opposite that of engine	3
ZF NL4C **	430	same as engine	3
ZF N221-10.B/C *	730	same as engine	25
HYDROCAR 2264 B/C	300	same as engine	13
HYDROCAR 2266 B/C	400	same as engine	13
AS 10 B	430	same as engine	22
HYDROCAR 17 AX	–	same as engine	–

Maximum torques are given for a rotating speed at the PTO input of 1500 rpm.

* Full-time use

** Part-time use < 60 minutes.

Drive ratio

Low

High

Power take-off	Gearbox								
	ZF 8S 151	ZF 9S 109	ZF 16S 109	ZF 16S 151	ZF 16S 181	ZF 12AS 2301 DD	EATON 5206 A	EATON 8309 A	ALLISON MD 3060
ZF NH 1B/C	1,09 1,09	0,77 0,77	0,75 0,93	0,91 1,09	0,77 0,91	1,35 1,35			
ZF NH 4B/C	0,98 0,98	0,99 0,99	0,96 1,17	0,82 0,98	0,98 1,17	1,21 1,05			
ZF NL 1C *	1,09 1,09			0,91 1,09	0,77 0,91				
ZF NL 4C	0,98 0,98			0,82 0,98	0,98 1,17				
ZF N221-10.B/C *	1,62 1,62			1,35 1,62	1,14 1,35				
HYDROCAR 2264 B/C									
HYDROCAR 2266 B/C									
AS 10 B						1,51 1,51			
HYDROCAR 17 AX									

Engine flywheel-mounted PTO

PAM 0631 and 0632
PAM 1131 and 1132

Make: ZF

Type: NMV 130

- maximum output torque: maximum engine torque
- drive ratio: 1.03
- flange output only
- engagement by multi-plate clutch

Maximum torque transmissible by the PTO

$$P = \frac{C \times n \times \eta}{9550}$$

P: power (kW)

C: drive torque (Nm)

n: engine rotating speed (rpm)

η : PTO drive ratio

Frequency of use of PTOs

- Full-time use:

Do not exceed half the maximum torque. In case of use at full power, it is essential to fit the PTO with a lubrication kit.

- Part-time use:

The maximum operating time is 30 minutes, followed by a minimum stop time of 30 minutes (for cooling down).

PTO control: consult the vehicle driving and servicing handbook.

The maximum rotating speed of the PTO output shaft is 3000 rpm.

For any PTO modification (output shaft, lubrication kit), contact the manufacturer's commercial network.

1.2 Instructions for the assembly of auxiliary hydraulic pumps to ZF type “C” PTOs

Connection of the hydraulic pump must correspond to standard ISO 7653, type D.

1.2.1 Supplementary instructions

Fluidtight seal between pump and PTO

The seal between the pump and the PTO must be made by two gaskets (**J1** & **J2**) with an air drain between the gaskets (**E**).

IMPORTANT

*The air drain (**E**) must guarantee that gearbox oil is not aspirated and that hydraulic oil does not penetrate inside the gearbox.*

The gaskets must be capable of withstanding temperatures reaching as high as 120°C.

The gasket (**J1**), fitted on the PTO side, must guarantee fluidtightness of the gearbox filled with oil specified by the manufacturer.

The gasket (**J2**), fitted on the pump side, must guarantee fluidtightness of the pump containing hydraulic oil. Correct operation of the air drain must be guaranteed at all times (do not paint it, blank it off or let it become fouled).

IMPORTANT

*In the event of oil leakage through (**E**), the entire system must be immediately checked out.*

1.2.2 Calculation of the weight torque

In the event of direct assembly of a hydraulic pump or another receiver (**2**) on the PTO (**1**), the weight torque should not exceed the value given in the PTOs characteristics table. Overstepping this value may lead to fast damage to the PTO or the gearbox.

Calculation method

$$C_p = P \times d$$

C_p: weight torque (Nm)

P: pump weight (N)

d: distance separating PTO contact face from the vertical passing through the centre of gravity (g) of the pump

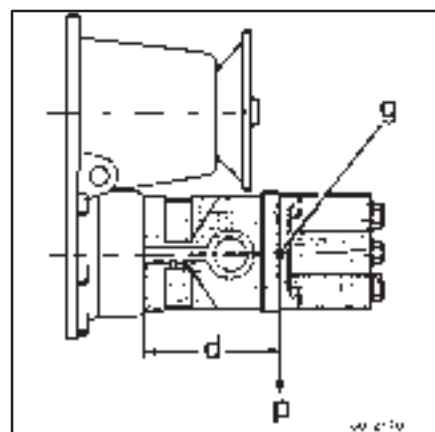
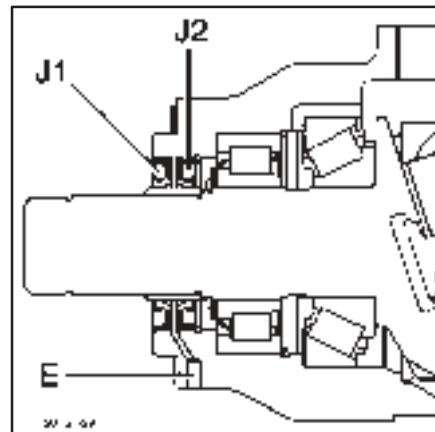

1.3 Access to gearbox

Modifications necessary to the bodywork to ensure maintenance on the "ZF" gearbox and retarder with day cab featuring low air intake and minimum sub-frame.

Assembly example

Bodywork lower cut-out part (tipper or tanker)

B2 - Body entrance

C - Sub-frame 60 mm

E - Body skin

F - Sidemember: 258/260 mm

L - Day cab back 205 mm

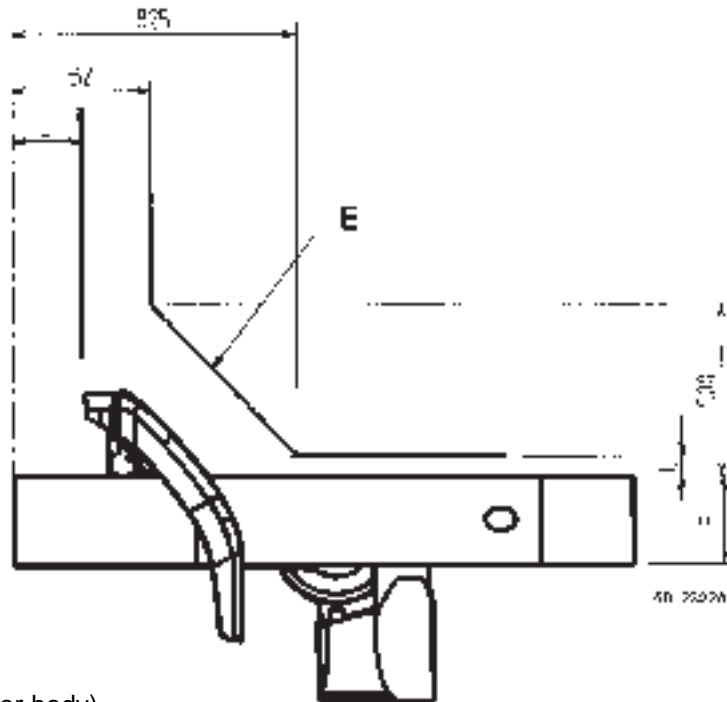

Inspection hatch in floor (refrigerator body)

X - axle centre-line

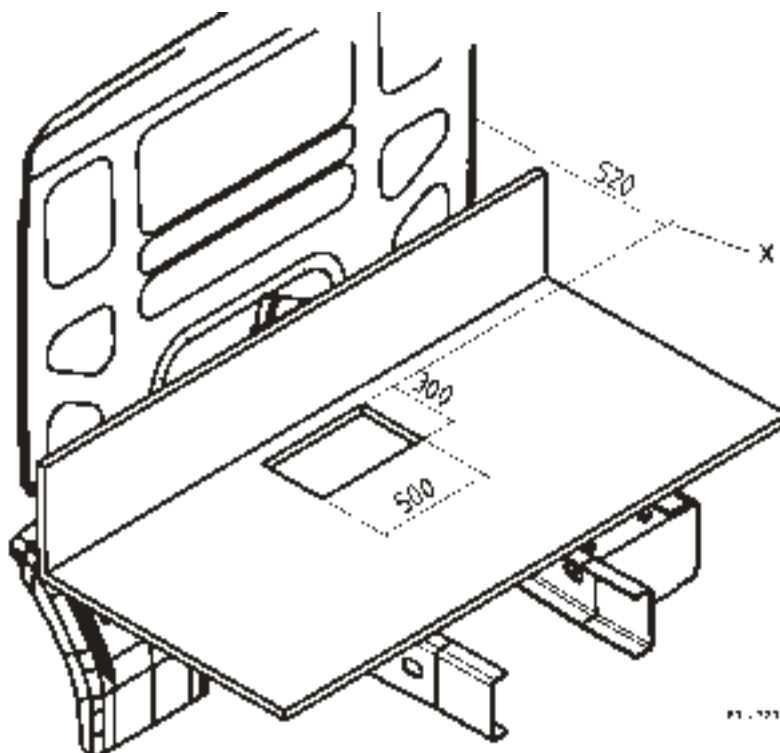

2. AIR-OPERATED EQUIPMENT

2.1 Connection of extra auxiliary equipment

The addition of extra auxiliary equipment not planned by the manufacturer must without fail be connected to the specific auxiliary equipment circuit.

The compressed air consumption of this auxiliary equipment should in no way compromise the braking circuit filling times laid down by the legislation in force.

The extra piping must be routed on the LH inner side of the chassis. Ensure fastening using nylon clamps.

If the vehicle is equipped with an electric retarder, route the piping in a heat shield.

For any further information, consult the RENAULT V.I. Product Applications Department.

2.1.1 Coupling for extra auxiliary equipment to chassis

There is a coupling for the connection of extra auxiliary equipment to the chassis provided on the vehicles.

A "multiple T" snap-on coupling, diameter 6 mm, closed by a blanking plug (1) with diameter 4 - 6 mm closed by a blanking plug (2) is arranged on the LH side under the plastic cover.

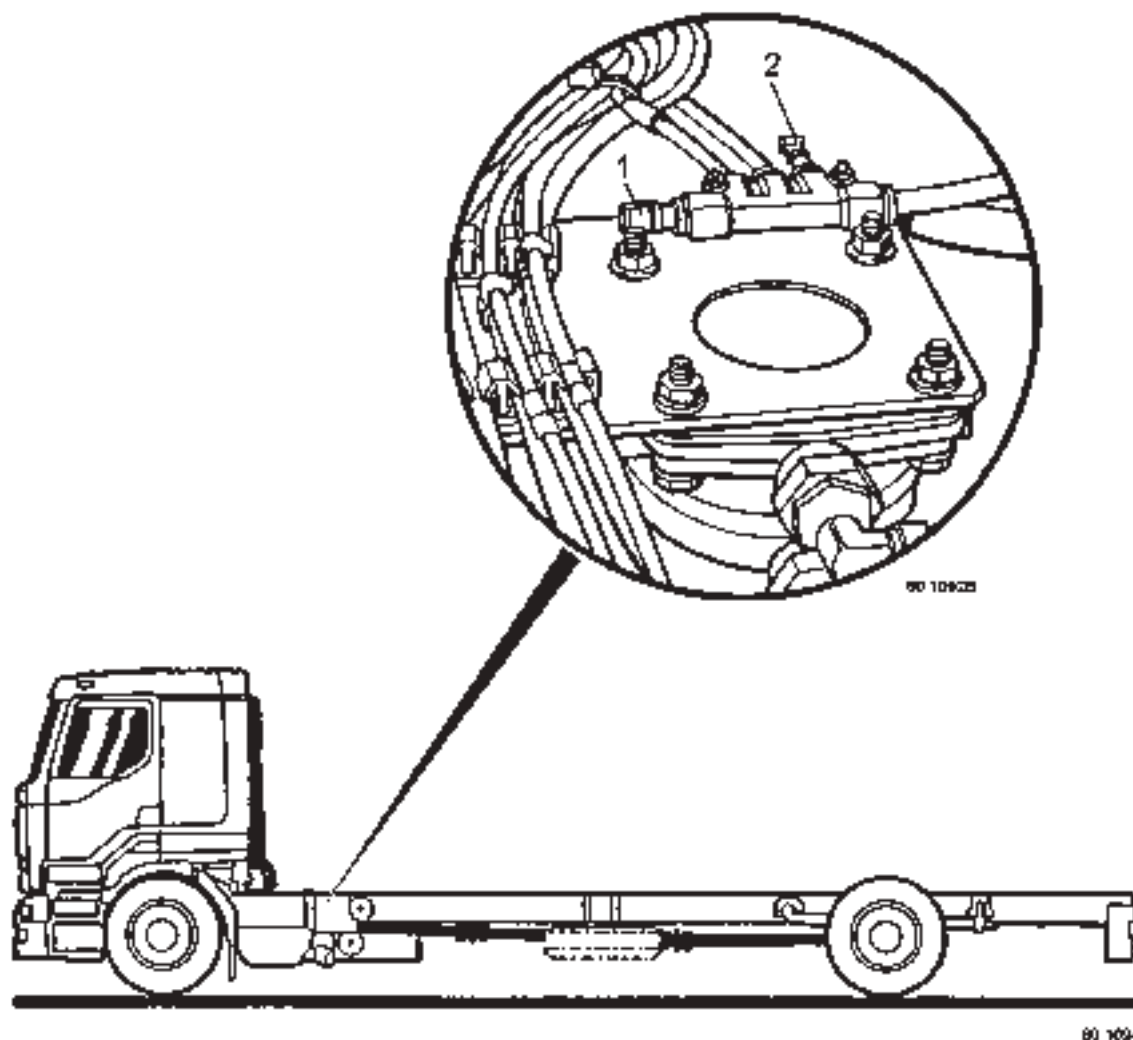

For pneumatic connection on vehicles not provided with coupling, hook up to the auxiliary equipment circuit (brown coloured mark) close to the air dryer.

Use snap-on couplings for connection:

- "Y" coupling diameter 6 mm ref. N° 50.05.330.278
- "T" coupling diameter 6 mm ref. N° 50.05.330.159.

The additional circuit should not cause any mechanical stress to the bracket.

Air-operated equipment + table of compressors

The addition of extra auxiliary equipment not planned by the manufacturer must without fail be connected to the specific auxiliary equipment circuit.

The compressed air consumption of this auxiliary equipment should in no way compromise **the braking circuit filling times laid down by the legislation in force.**

The **RENAULT V.I.** Product Applications Department is at your disposal for any further information.

The assembly of extra equipment piping must be routed in the trough located on the left-hand side inside the chassis.

If the trough does not allow passage of extra equipment piping, route the pipe on the outside of the trough. Hold the pipe with "COLSON" clamps.

If the vehicle is equipped with an electric retarder, route the auxiliary equipment piping between the heat shield and the trough.

Connection diagram

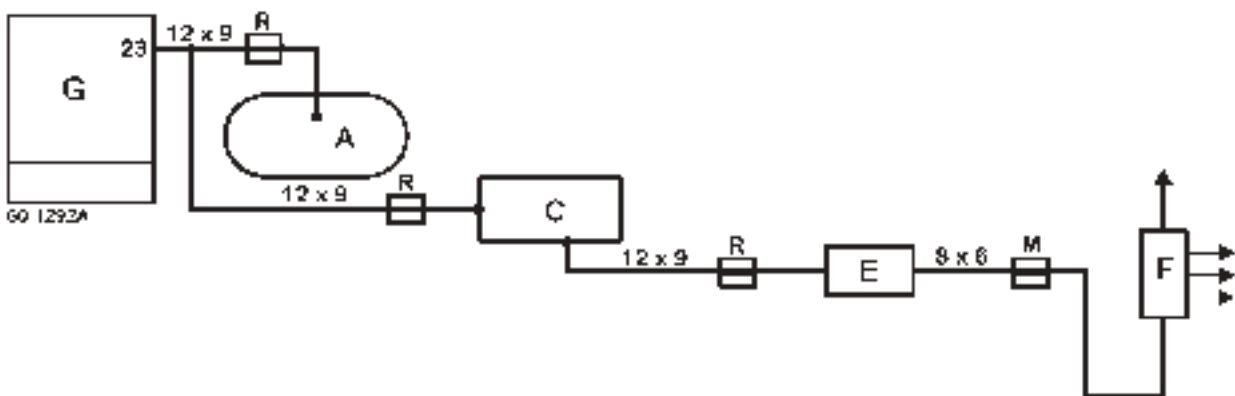

- A - Trailer and parking brake air tank
- C - Pressure reducing valve
- E - Overflow valve
- F - Bodybuilder's socket
- G - Pressure gauge block
- R - Red coloured ring
- M - Brown coloured ring

Table of compressors (vehicle stationary)

COMPRESSOR TYPE	COMPRESSOR DISPLACEMENT	DRIVE RATIO	DUTY PRESSURE Output at 12.5 bar at 1500 rpm Air suspension
LP 3833 LP 4819	Single-cylinder 250 cc Twin-cylinder 500 cc	1,03	
LP 4819	Twin-cylinder 500 cc	1,03	400 L/min
LP 3833 LP 4819	Single-cylinder 250 cc Twin-cylinder 500 cc	1,31	
LP 4819	Twin-cylinder 500 cc	1,31	500 L/min
LP 4845	Twin-cylinder 500 cc	1,31	500 L/min
LP 3833	Single-cylinder 250 cc	1,31	
LP 4819	Twin-cylinder 500 cc	1,31	500 L/min
LP 4845	Twin-cylinder 500 cc	1,31	500 L/min

3. ELECTRICS

3.1 Earths

3.1.1 Cab earths

Cab fastenings are by means of M6 stainless steel studs welded to the cab.

Front end earths

- 1 - Stainless steel stud M6 welded to front end panel
Connection unit - Cab
- 2 - Stainless steel stud M6 welded to front end panel
Cab - Chassis

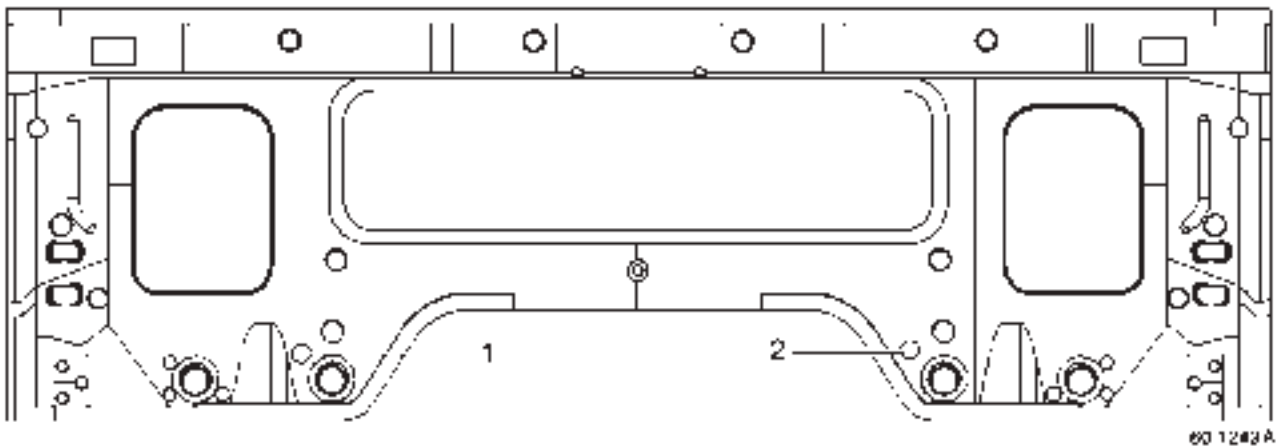

Fastening of earth lug or braid to cab

- 1 - Front end panel
- 2 - Stainless steel washer diameter 6 mm
- 3 - Stainless steel stud M6 welded to front end
- 4 - Stainless steel nut M6
- 5 - Earth lug or braid

Nut (4) tightening torque: 9 ± 1 Nm

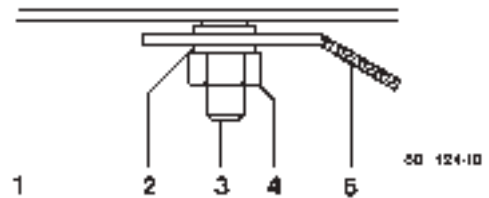

3.1.2 Chassis earths

All chassis earths are on the LH sidemember through 11 or 13 mm diameter holes.

- 1 - Cab + shield earth (Ø 13)
- 2 - Starter earth (Ø 13)
- 3 - Trailer socket earth (tractors) (Ø 11)
- 4 - Battery earth (Ø 11)
- 5 - Electric retarder earth (Ø 11)
- 6 - Rear wiring harness + trailer socket earth (drawbar rigids)
- A - Painted sidemember
- B - Specific tinned surface (Ø 45)
- C - Electrical earths fixing hole (Ø 11 or Ø 13)

Apart from the battery and cab earths located to the outside of the chassis, all the earths are fastened to the inside of the sidemember.

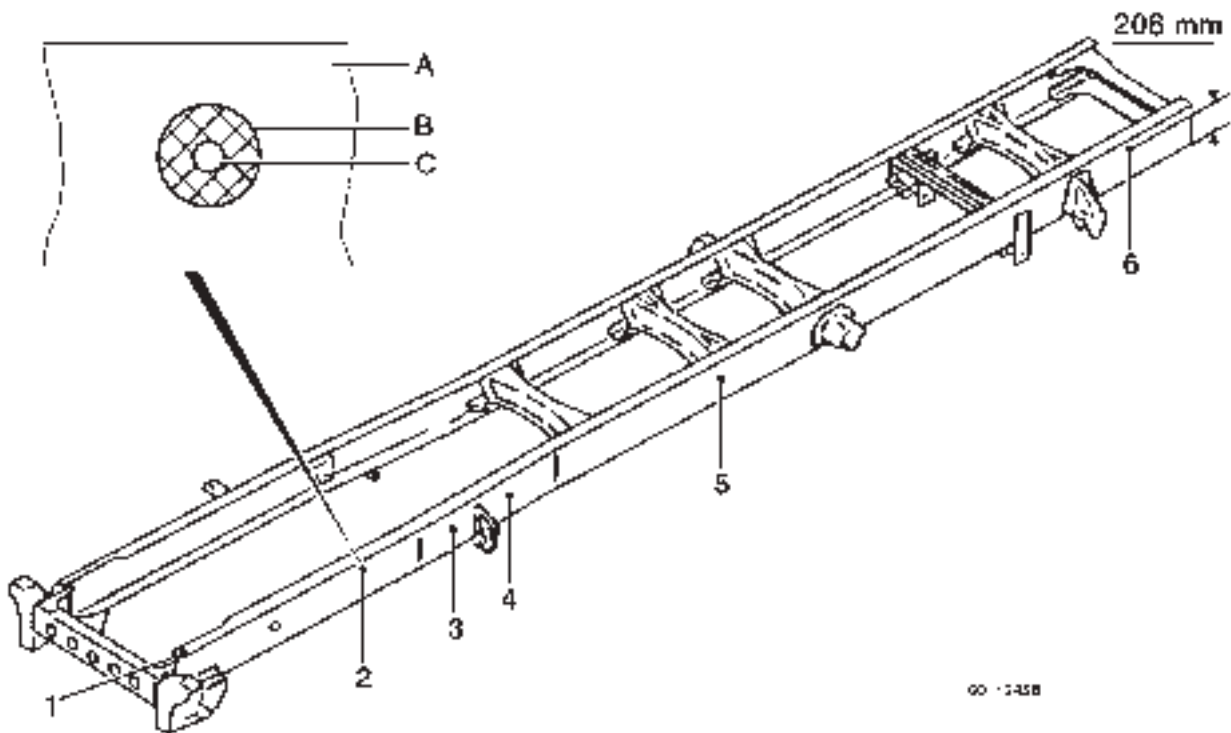

Assembly to electrical earth points diameter 11 mm

- A - Tinned surface Ø 30 mm
- B - Plain stainless steel washer Ø 10 mm
- C - Stainless steel nut H10 x 150
- D - Earth lug or braid
- E - Sidemember
- F - Stainless steel bolt M10 x 150.

Tightening torque: 45 ± 9 Nm

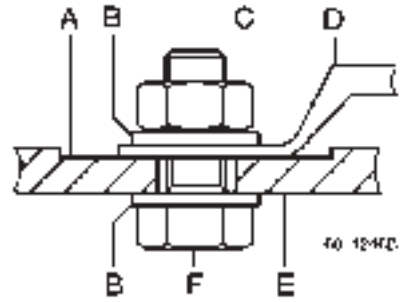

Assembly to electrical earth points diameter 13 mm

- A - Tinned surface Ø 45 mm
- B - Plain stainless steel washer Ø 10 mm
- C - Stainless steel nut H10 x 150
- D - Earth lug or braid
- E - Sidemember
- F - Stainless steel bolt M10 x 150.

Tightening torque: 45 ± 9 Nm

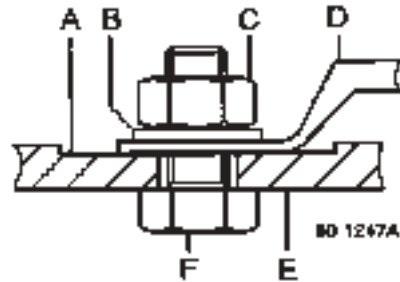

Making an electrical earth

When the rear overhang is modified, it is necessary to find a new location for the electrical earth. Some equipment needs to be connected to earth at a point other than on the originally planned earths. In these cases, the operating procedure is as follows:

- Mill dia. 45 mm, using a shouldered spotfacing cutter (surface finish R 40).
- Tin the surface, using a product containing 40% silver, temperature 230°C, min. thickness 4 μm^2 .

3.2 Passage of wiring harnesses and compressed air pipes

Two routings have been provided on the cab for the passage of wiring harnesses to ensure a link between the inside of the cab and the chassis (RH & LH sides).

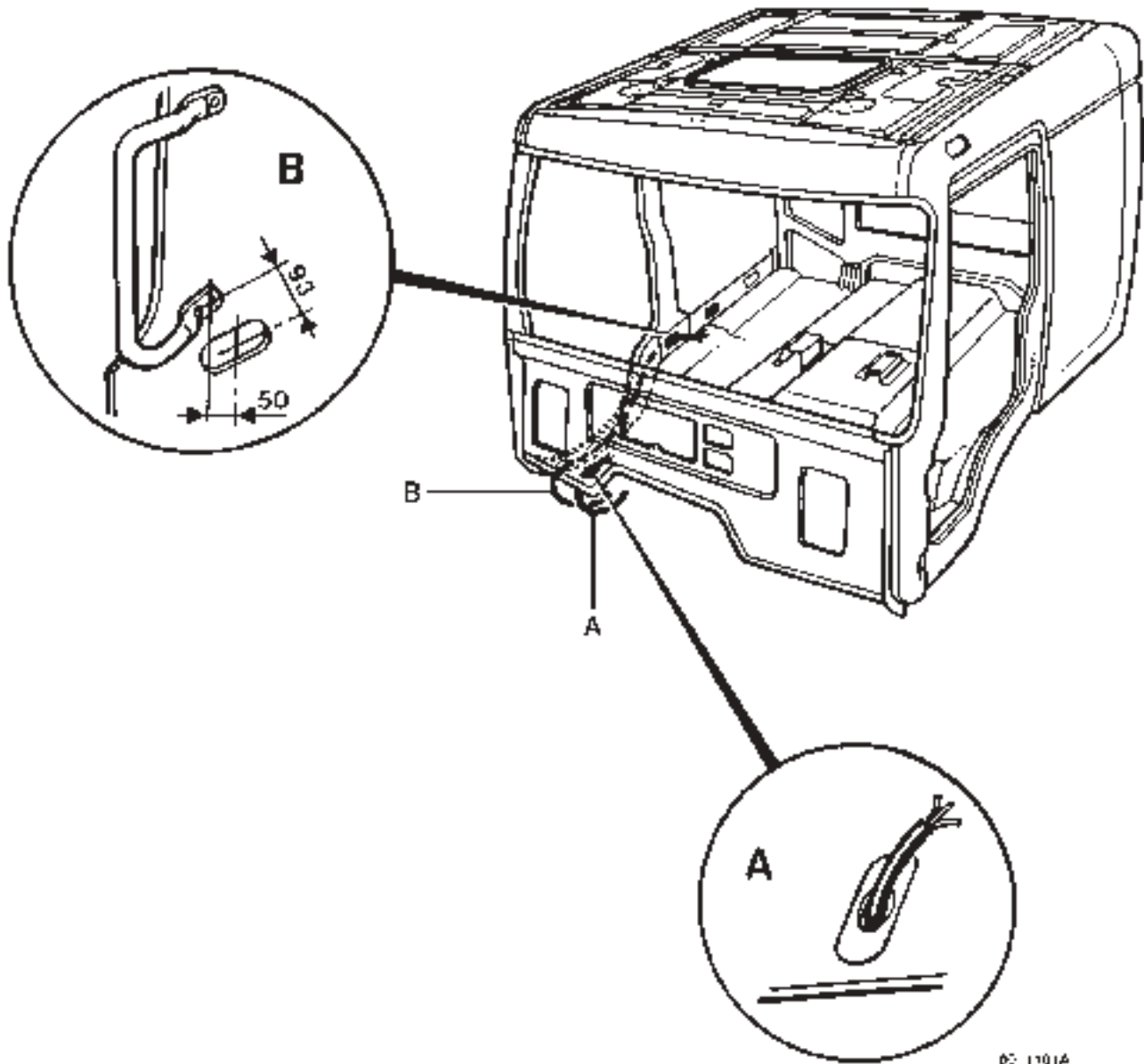

Two solutions

- A - In the \varnothing 45 mm impression on the sheet metal floor:
Drill a hole to allow the passage of a wiring harness.
Fit a grommet to provide a tight seal.
- B - Cut out the lining and pass the wiring harness through the rail to gain access to the chassis.

4. CHASSIS

4.1 Steel classes for sidemembers

Sidemembers are cascade down into one class of steel (chapter A-2.1.4):
 - class F for the entire series.

4.2 Sections of sidemembers

Vehicle	Tonnage (tonnes)	Wheelbase (mm)	Sidemember section
4x2 rigid	18	3815	244 x 82 x 7 276 x 82 x 7
		4090	
		4365	
		4750	
		5190	244 x 82 x 8 276 x 82 x 8
		5575	
		5960	
		6400	
4x2 rigid	19	6785	276 x 82 x 7
		3815	
		4090	
		4365	
		4750	276 x 82 x 8
		5190	
		5575	
		5960	
6400			
6785			

Vehicle	Tonnage (tonnes)	Wheelbase (mm)	Sidemember section
6x2 rigid	26	3815	244 x 82 x 7 276 x 82 x 7
		4090	
		4365	
		4750	
		5190	244 x 82 x 8 276 x 82 x 8
		5575	
		5960	
		6400	

Vehicle	Tonnage (tonnes)	Wheelbase (mm)	Sidemember section
6x2/4 rigid	26	3815	276 x 82 x 7
		4090	
		4365	
		4750	
		4475	276 x 82 x 7
		4805	
		5245	
		5740	

4.3 Reinforcement, extension, shortening of sidemembers in the rear overhang

If the bodywork or fitted equipment do not modify the chassis weight and dimensions entered in the descriptive notice, the vehicle can be presented to the Type Approval department without intervention from RENAULT V.I. (within the permitted limits in force).

In the event of chassis extension, take care to use a section with size and steel grade identical to those of the sidemembers (consult the chapter "Section and class of sidemember steels"). Contact the RENAULT V.I. Product Applications Department for any further information or to get a list of sales outlets marketing such sections.

4.3.1 Modification to the rear overhang

In the event of extension of the rear overhang, take into consideration the regulations in force and in particular the overhang / wheelbase ratio.

4.4 Intermediate cross-member

After extension to the rear overhang or the wheelbase ($D > 1850$ mm):

The fitting of an intermediate cross-member or relay cross-member is vital if the number of cross-members in the extended vehicle is less than those for the corresponding standard vehicle.

Consult the RENAULT V.I. Product Applications Department.

Note

The cross-member that may have to be added will be different depending on the place where the sidemember is sectioned for the purpose of extension. It is therefore strongly advised, before proceeding with cutting, to determine:

- if there is any need to add a cross-member,
- the point where the fitting of the cross-member will be the easiest (e.g. fitting of a simple cross-member rather than a relay cross-member). Consult the RENAULT V.I. Product Applications Department.

Procurement

On account of the diversity of assemblies, consult the Product Applications Department to find out the reference number and position of the cross-member to be added.

- 1 cross-member ref. N° 0000 782 454
- 2 gussets ref. N° 0000 782 452

Threaded hardware to be used for fastening cross-members to chassis:

- 16 collar bolts HM14x 150 x 40 class 10.9
- 16 flanged locknut HM14 x 150 class 10
- 32 plain washers 14 x 30 x 5.

Tighten to torque (see chapter A-2.5).

- A - Cross-member centre-line
- B - Drive axle centre-line
- C - Sidemember rear overhang
- D - Max. dimension 1850 mm

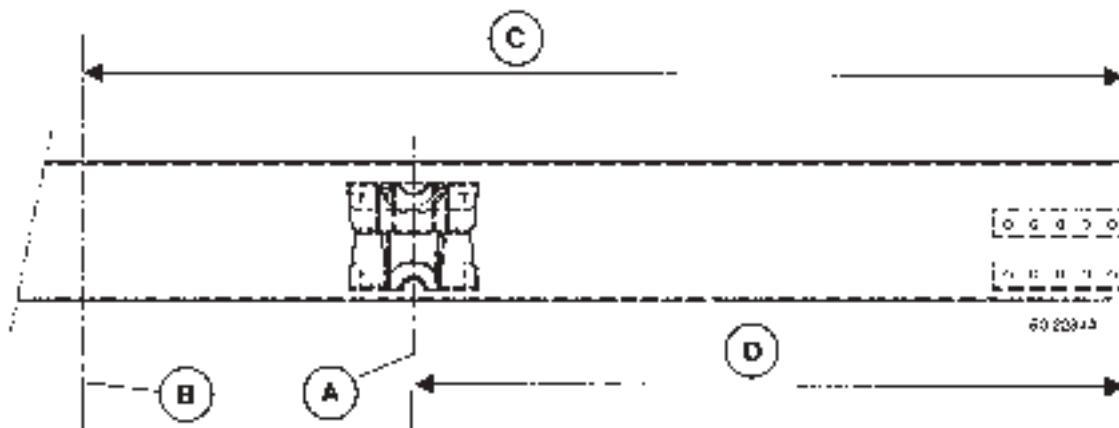

5. CHANGING THE POSITION OF EQUIPMENT ON CHASSIS

5.1 Rear run-under guard

Whatever the position of the rear run-under guard in relation to the chassis, distances (A) and (B) are to be observed without fail.

- 1 - Body rear overall (including fittings, hinges...)
- 2 - Run-under guard
- 3 - Ground

The thickness of fittings and hinges should not exceed 120 mm (distance between centre-line (1) and the rear end of the body).

Vehicle	A* (mm)	B (mm)
Rigid 18 - 19 - 22 - 24 - 26 tonnes	0 to 348 max.	550 max. unladen

* after deformation

- A - maximum distance separating the run-under guard to the body rear overall
- B - maximum height of run-under guard in relation to ground, vehicle unladen

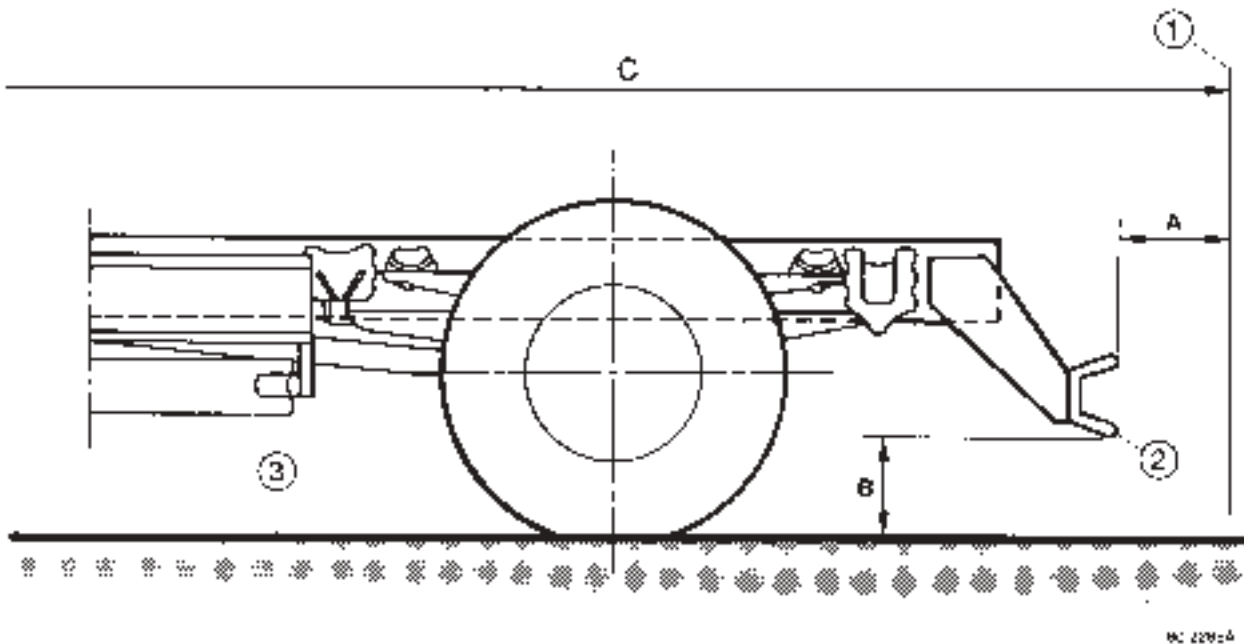

6. HITCH COUPLING FOR DRAWBAR RIGID TRAILERS (TRAFFIC DIRECTIVE N° 15011407)

A = 18,75 m
 B = 16,40 m
 W1 + W2 = 15,65 m

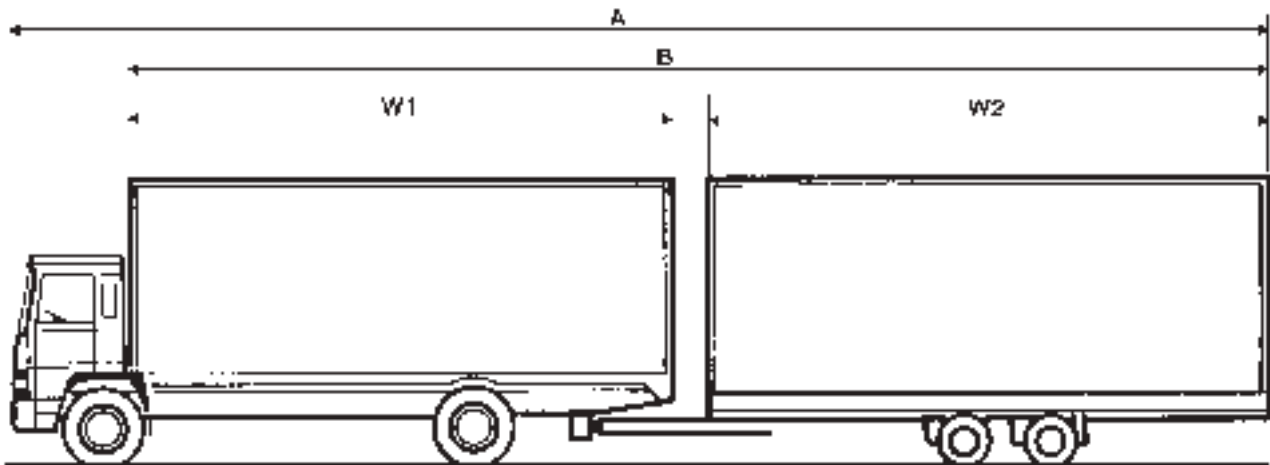

Rear extremity of tractor vehicle

GO 1207A

Class Designation	Dimension A (mm)	Dimension B (mm)
1400	1400 -100	425 ± 25
1600	1600 -100	425 ± 25
1900	1900 -100	425 ± 25

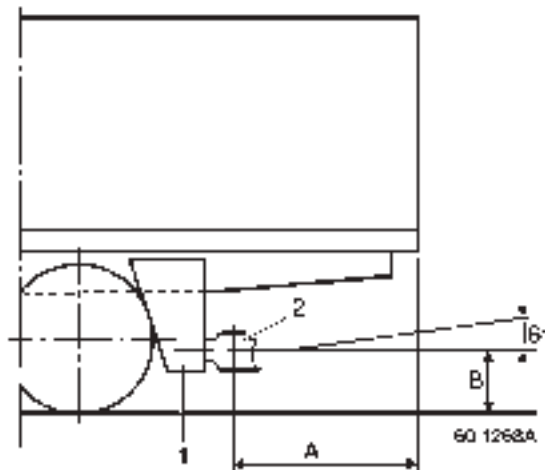

Trailer forward clearance

S = Running clearance sector
 S = 250 mm
 C = Radius of articulation
 W = Body width

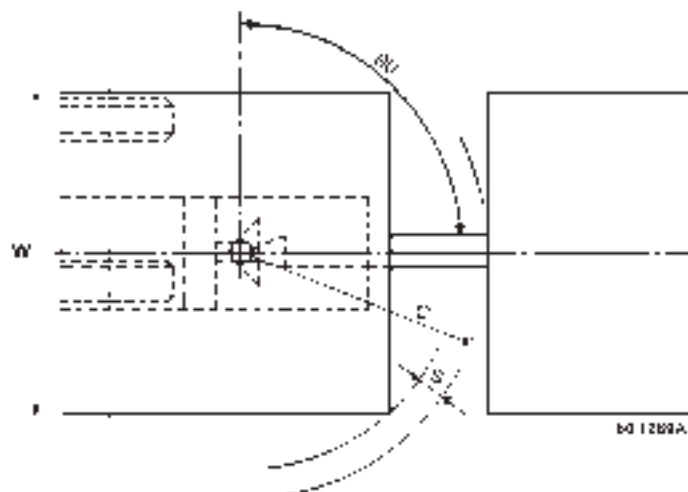

6.1 Mounting principle

4x2 rigid, 19 tonnes, wheelbase 5575 mm

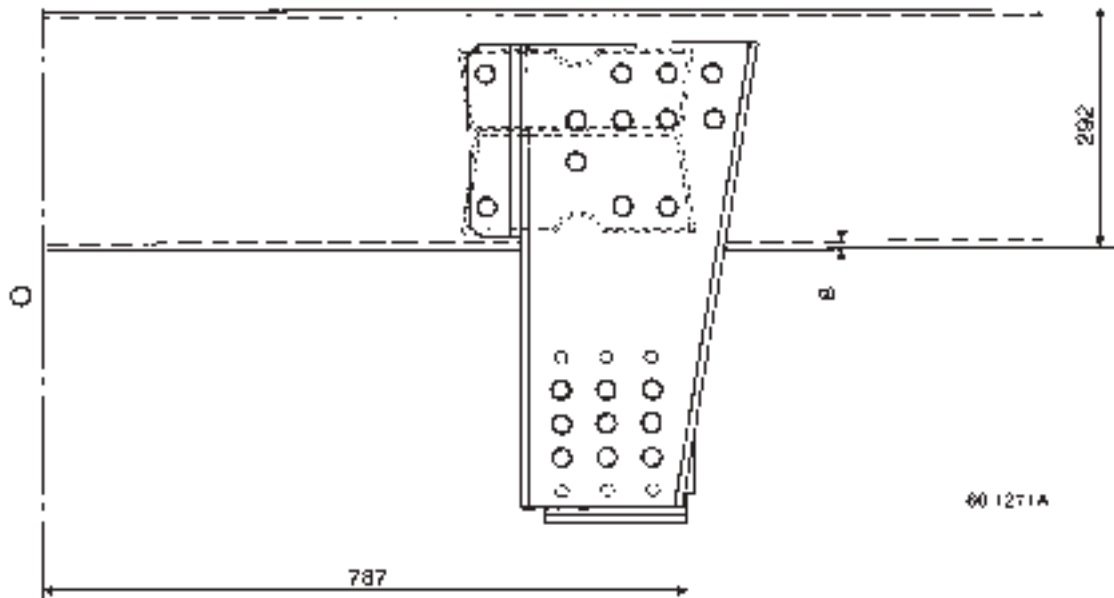

0 = 6x2 rear drive axle or rear axle centre-line

4x2 rigid, wheelbase 5960 mm
6x2 rigid, wheelbase 5190 mm

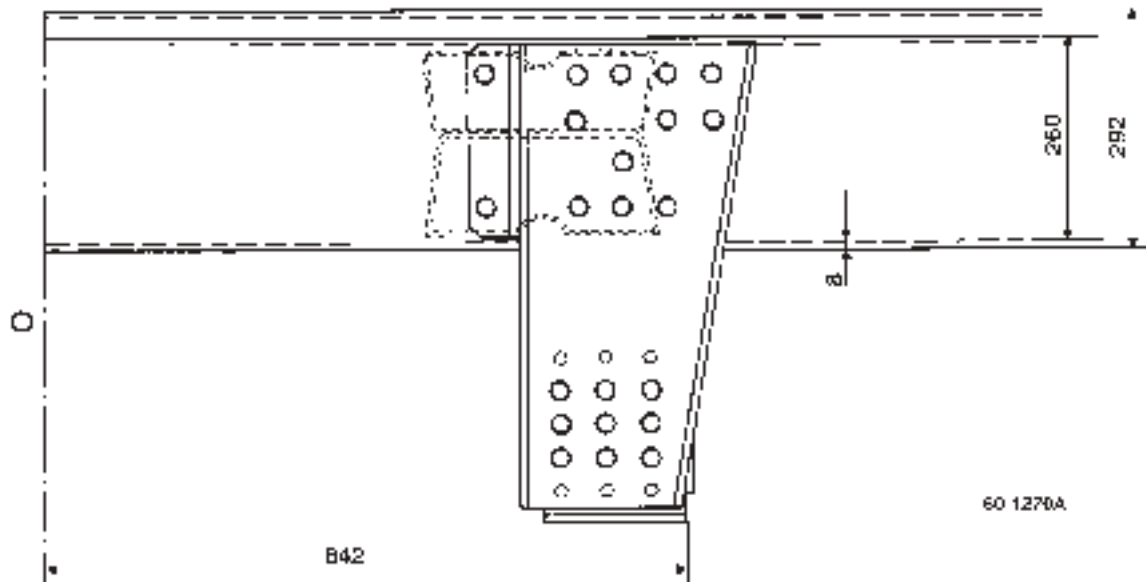

0 = Rear drive axle centre-line

For the other wheelbases, use the same principle in conformity with the directive.

6.2 Rear bevelling of sidemembers

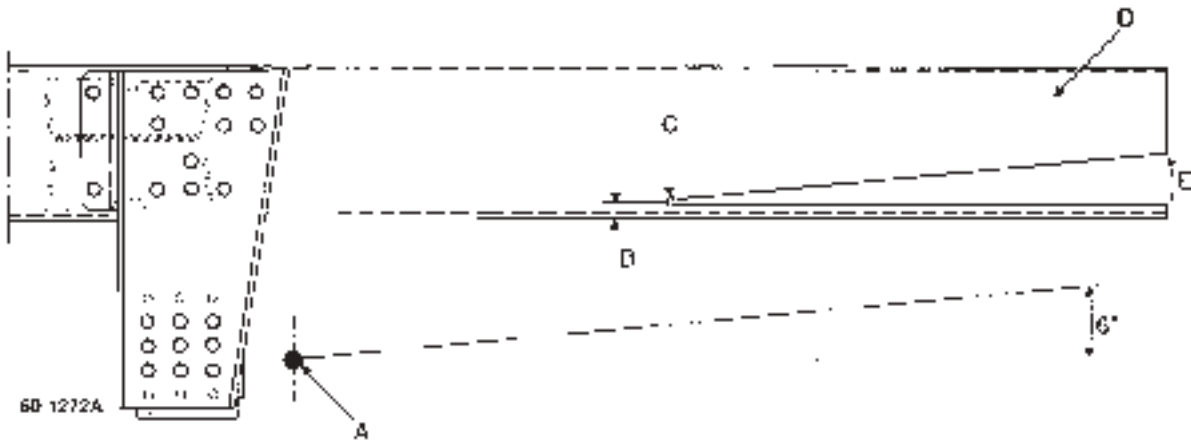

- A = Hook centre-line
- B = Dimension 20 mm
- C = Holes \varnothing 15 mm max.
- D = Sidemember
- E = Bend

Method:

- Cut the web of the sidemembers (D).
- Bend the lower flange of the sidemembers as in (E).

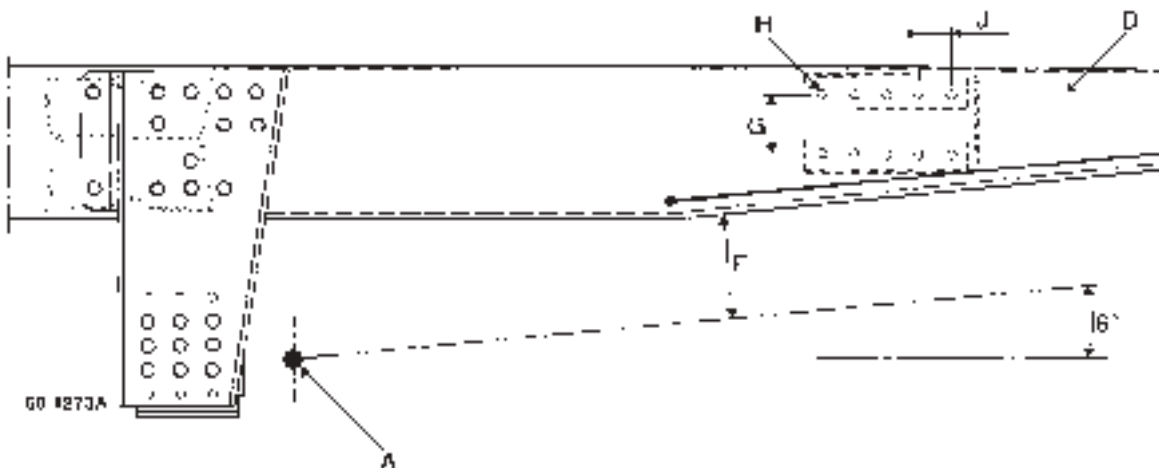

- A = Hook centre-line
- D = Sidemember
- F = Trailer tongue radius
- G = 105 mm
- H = Cross-member
- J = 55 mm

Method:

- Weld the sidemembers (D) as per RENAULT V.I. recommendations.
- Position the rearmost cross-member (H) and drill the sidemembers.

6.3 Attachment of towing hook to 40-44 tonne and 50-60 tonne cross-member

40-44 T cross-member diagram

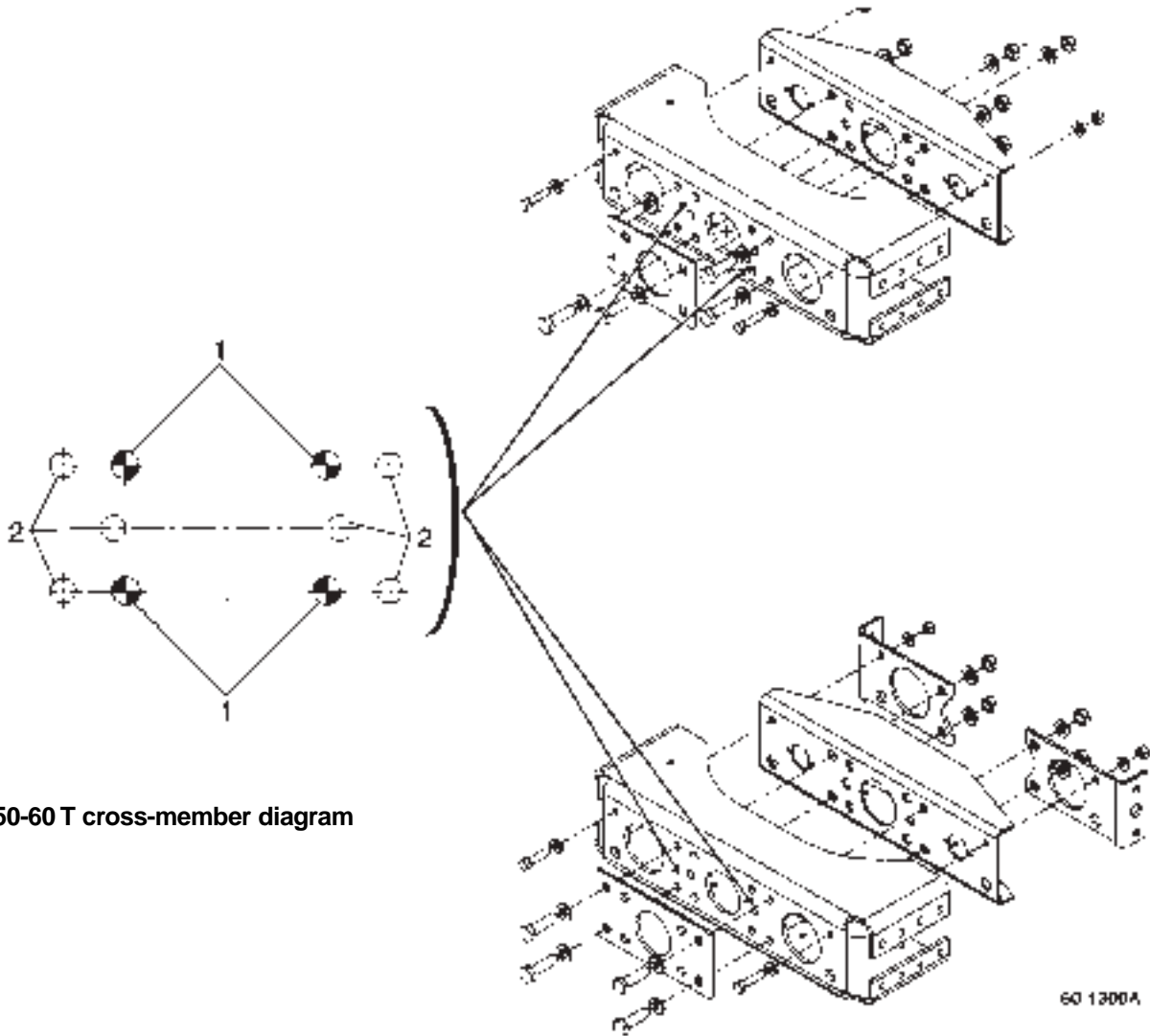

50-60 T cross-member diagram

- Use the holes (1) to assemble the "DIN" towing hook to the cross-member.
- Use the holes (2) to assemble the "BNA" towing hook to the cross-member.

Hook position

(See chapter A).

The dimension X (cross-member rear face / rear drive axle centre-line) depends on wheelbase, axle spread and GVW.

The position of the hook centre-line is constant (107 mm) in relation to the chassis zero point.

L = Sidemember

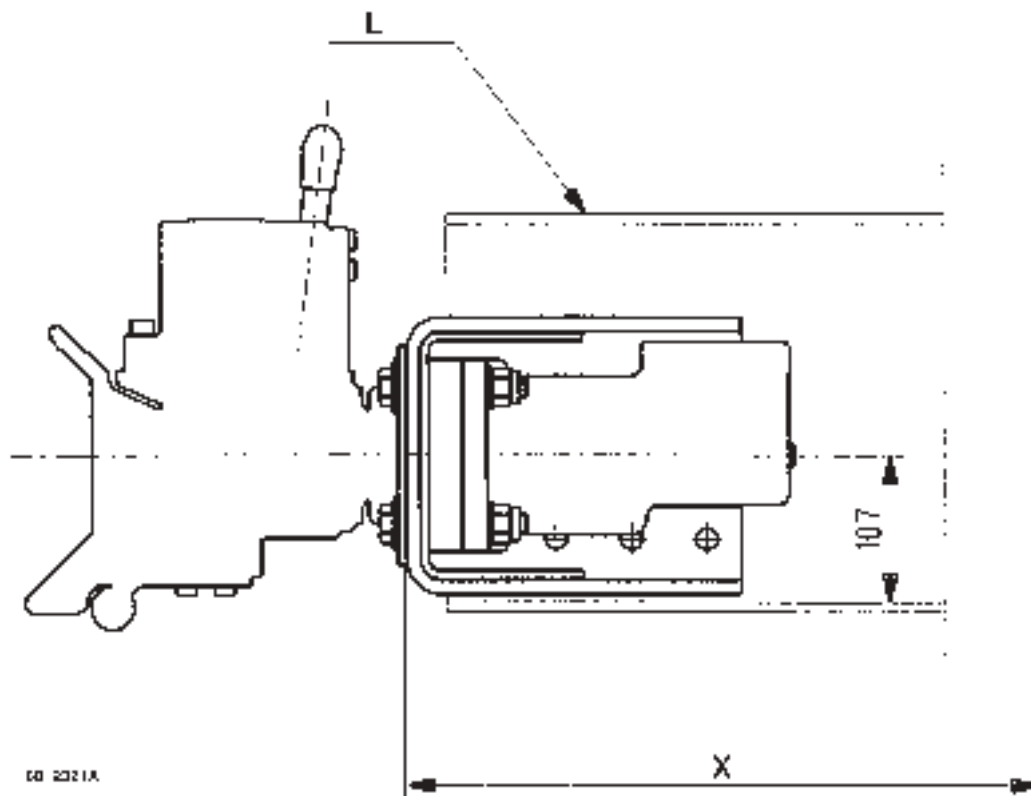

60 2321A

7. ASSEMBLY OF EQUIPMENT TO CAB

7.1 Roof catwalk

The cab roofs are designed to accommodate the attachment of a catwalk.

7.1.1 Attachment of catwalk to day cab

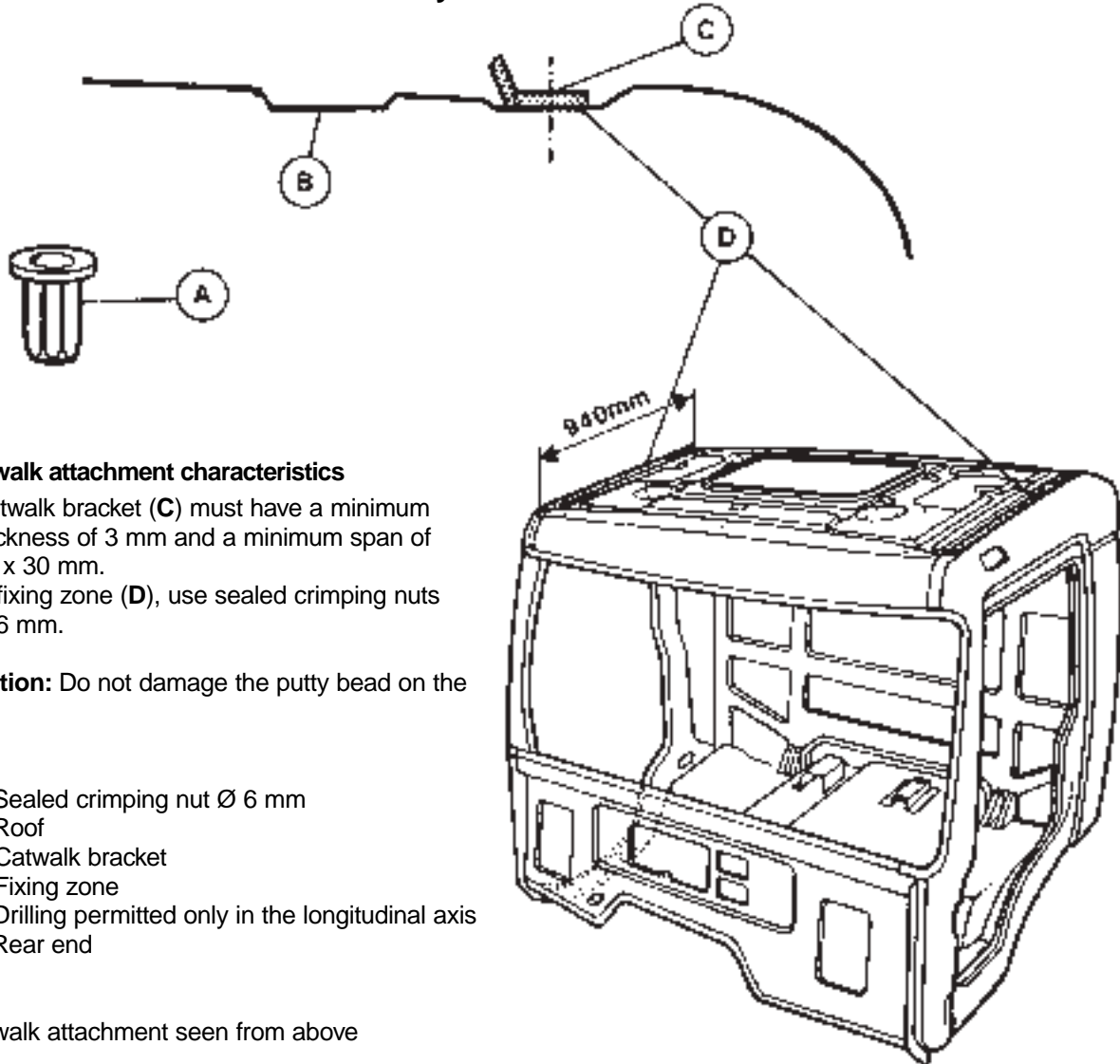

Catwalk attachment characteristics

- Catwalk bracket (C) must have a minimum thickness of 3 mm and a minimum span of 30 x 30 mm.
- In fixing zone (D), use sealed crimping nuts \varnothing 6 mm.

Caution: Do not damage the putty bead on the roof.

- A - Sealed crimping nut \varnothing 6 mm
- B - Roof
- C - Catwalk bracket
- D - Fixing zone
- E - Drilling permitted only in the longitudinal axis
- F - Rear end

Catwalk attachment seen from above

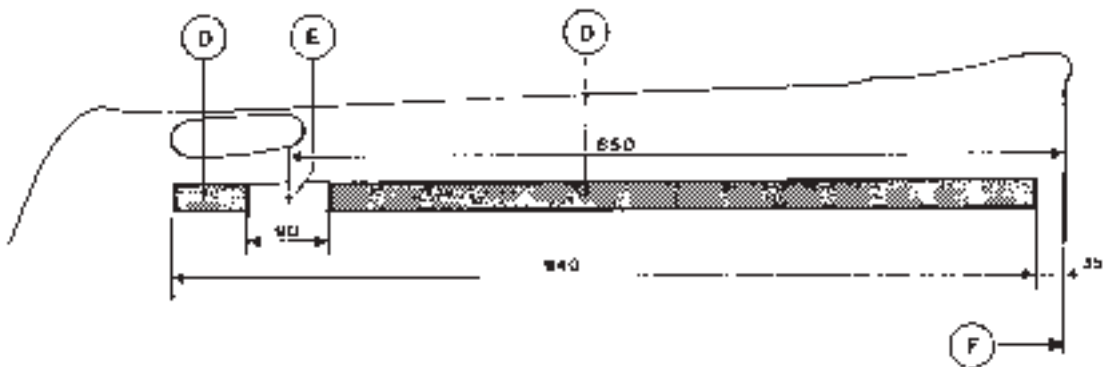

BU1111

7.1.2 Attachment of catwalk to sleeper cab

Catwalk attachment characteristics

- Catwalk bracket (C) must have a minimum thickness of 3 mm and a minimum span of 30 x 30 mm.
- In fixing zone (D), use sealed crimping nuts \varnothing 6 mm.

Caution: Do not damage the putty bead on the roof.

- A - Sealed crimping nut \varnothing 6 mm
- B - Roof
- C - Catwalk bracket
- D - Fixing zone
- E - Drilling permitted only in the longitudinal axis
- F - Rear end

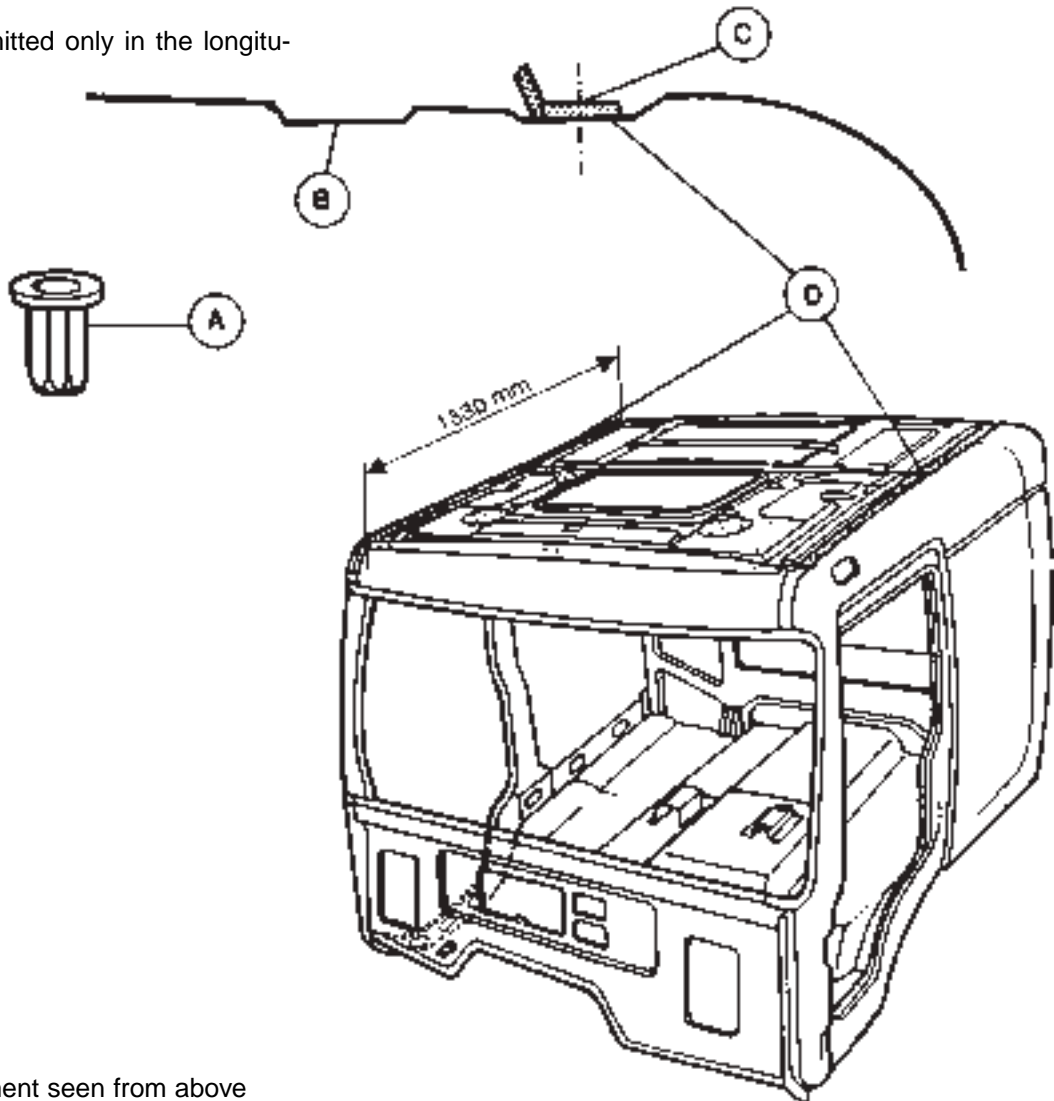

Catwalk attachment seen from above

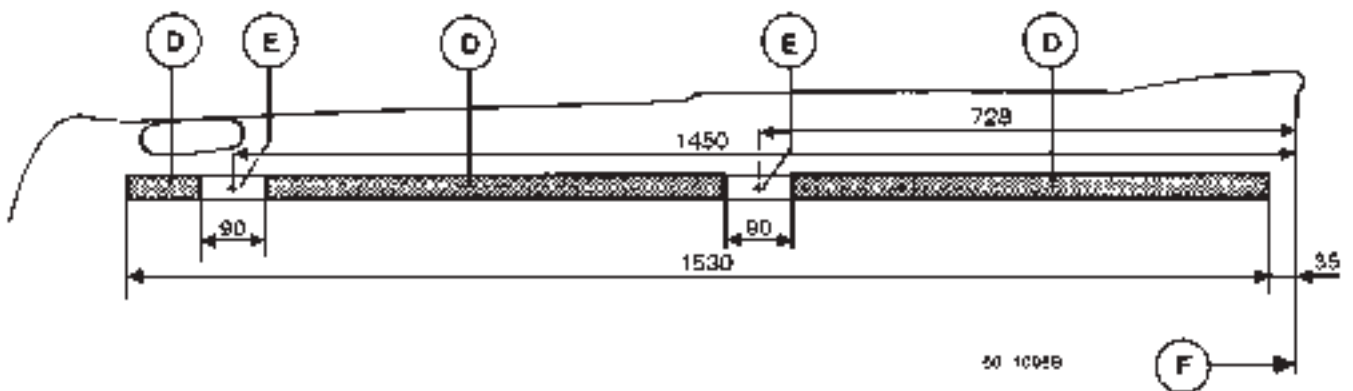

7.2 Ladder

The design of the roof and the lower parts of the cab sides allow a ladder to be attached on the LH side or on the RH side, except for the RH side of day cabs.

7.2.1 Attachment of ladder to day cab

Ladder attachment characteristics

The ladder brackets (C-E) at the top and at the bottom must have a minimum thickness of 3 mm and a minimum span of 30 x 30 mm.

Top part (zone F):

- one or two sealed crimping nuts M6.

Bottom part (zone C):

Two possibilities:

A - 4 sealed crimping nuts M6 (two at the front and two at the rear of zone (C)).

B - 2 sealed crimping nuts M8 (one at the front and one at the rear of zone (C)).

A - Sealed crimping nut M6

A - Sealed crimping nut M8

C - Lower fixing zone

D - Roof

E - Ladder upper attachment bracket

F - Upper fixing zone

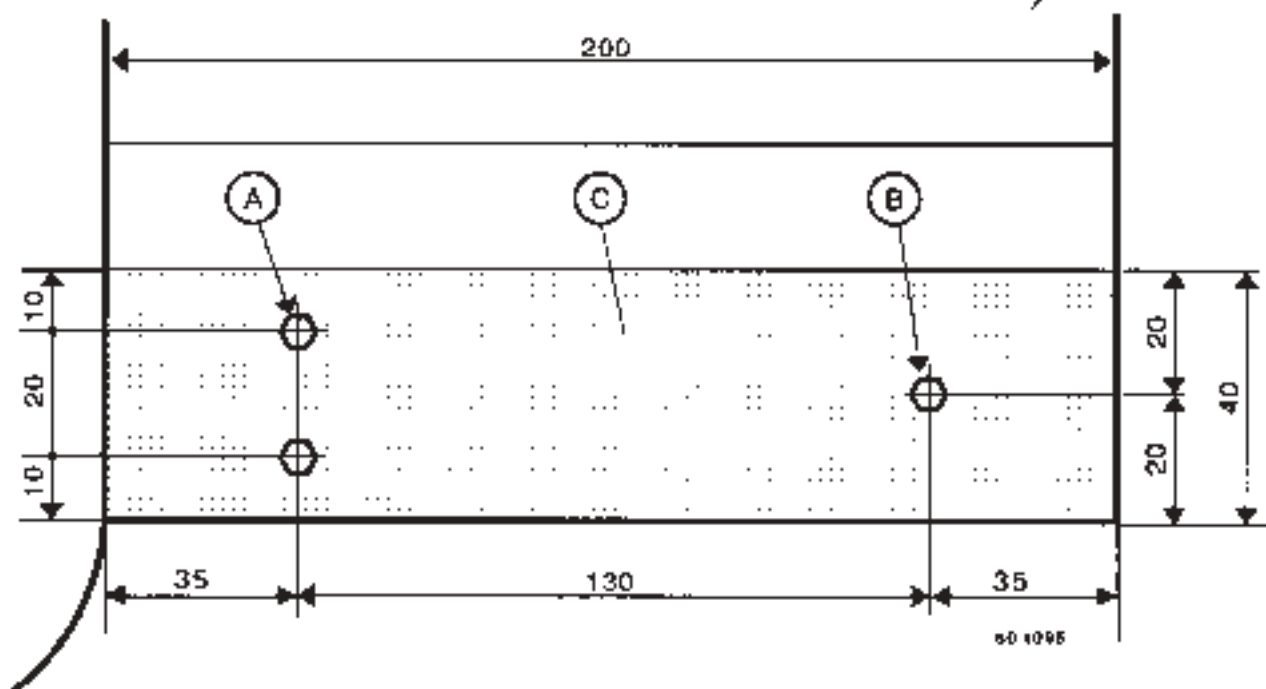
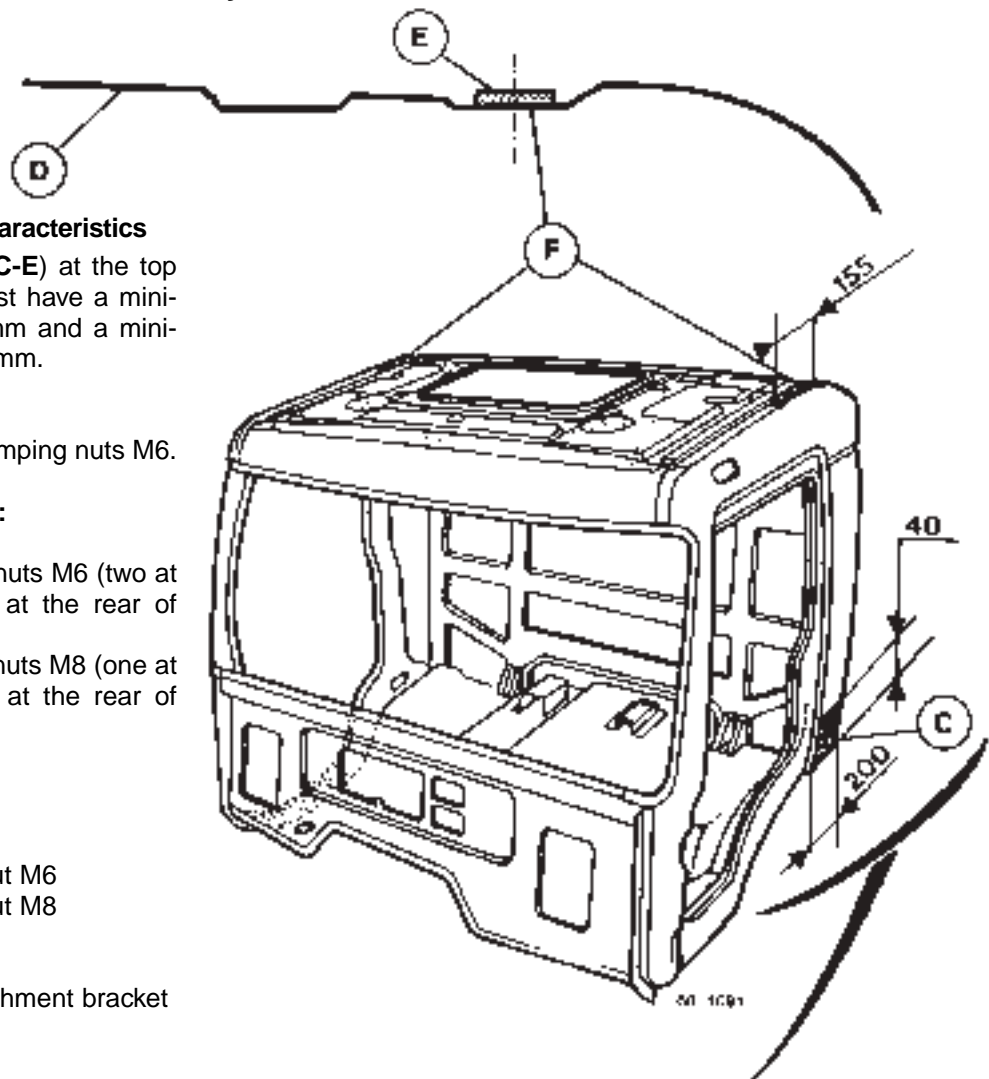

7.2.2 Attachment of ladder to sleeper cab

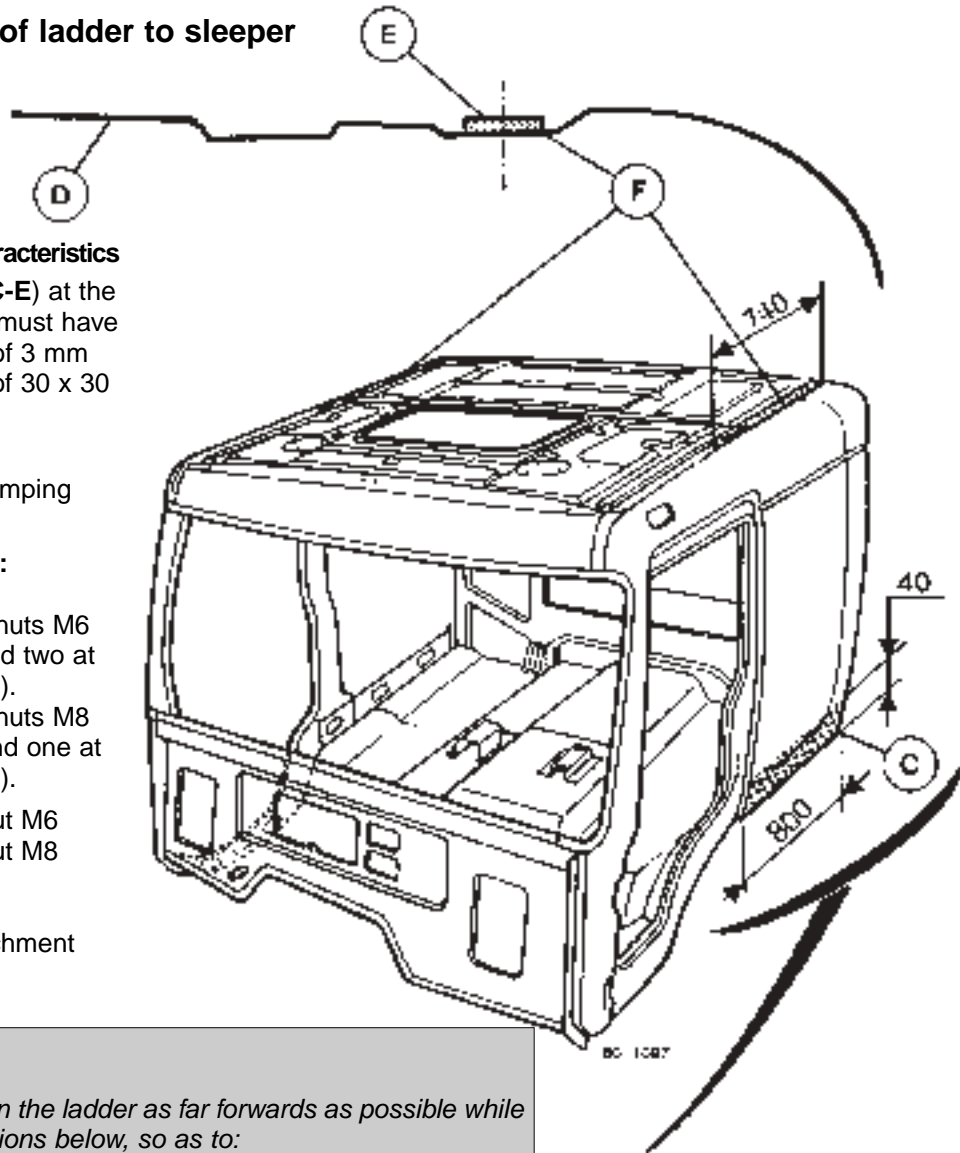

Ladder attachment characteristics

The ladder brackets (C-E) at the top and at the bottom must have a minimum thickness of 3 mm and a minimum span of 30 x 30 mm.

Top part (zone F):

- one or two sealed crimping nuts M6.

Bottom part (zone C):

Two possibilities:

- A - 4 sealed crimping nuts M6 (two at the front and two at the rear of zone (C)).
- B - 2 sealed crimping nuts M8 (one at the front and one at the rear of zone (C)).

- A - Sealed crimping nut M6
- A - Sealed crimping nut M8
- C - Lower fixing zone
- D - Roof
- E - Ladder upper attachment bracket
- F - Upper fixing zone

IMPORTANT

It is advised to position the ladder as far forwards as possible while observing the dimensions below, so as to:

- facilitate access to the ladder,
- avoid any interference between the ladder and external lugs on chassis or cab.

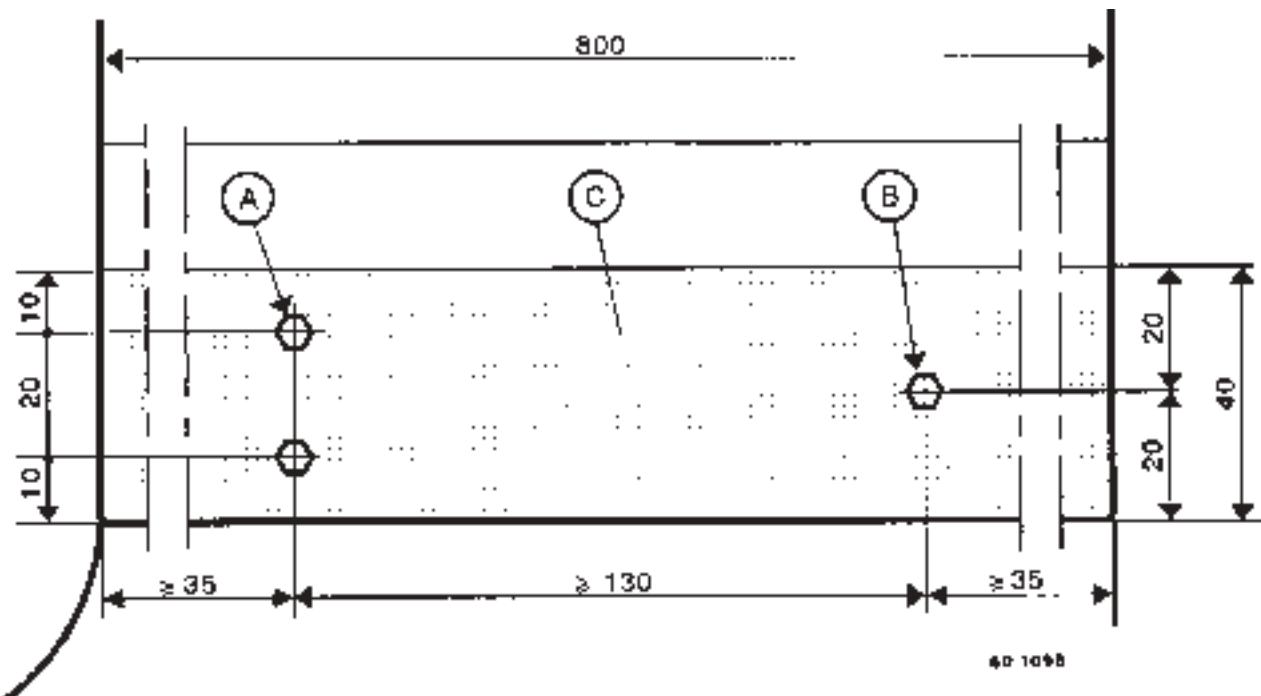

7.3 Assembly of accessories on roof

IMPORTANT

The roof is different according to the cab original fitment equipment:

- Welded fixing nuts (1) for the deflector are used only with roof stiffeners on cabs equipped with deflector as standard.
- Sunshade, frontview mirror and gantry are components requiring the presence of a stiffener (2) welded as standard to the cab for their installation. This stiffener, located in an inaccessible zone, cannot be assembled as aftermarket fitment. On account of this, installation of sunshade, gantry and frontview mirror can only be carried out if certain conditions are met. Installation possibilities are detailed in chapter C-7.3.5, 7.3.6, 7.3.7.

Equipment capable of being assembled, whatever the roof:

- Revolving beacons
- CB radio antenna
- Telephone antenna
- Air horns.

On the roof, impressions locate the position of accessory fastenings

7.3.1 Installation of antennae

CB radio antenna:

- Wiring harness passage: at point (3), drill a hole diameter 4.5 mm.
- Antenna fastening: at point (4), drill a hole diameter 8.5 mm.

Telephone antenna

- At point (1), drill a hole diameter 14.5 mm.

Fire antenna

- Locate drilling point (2) using the template supplied in the installation kit.
- Drill a hole diameter 24.5 mm.

The wiring harness passages must be hermetically sealed. Use a wire grommet and sealing compound, if necessary

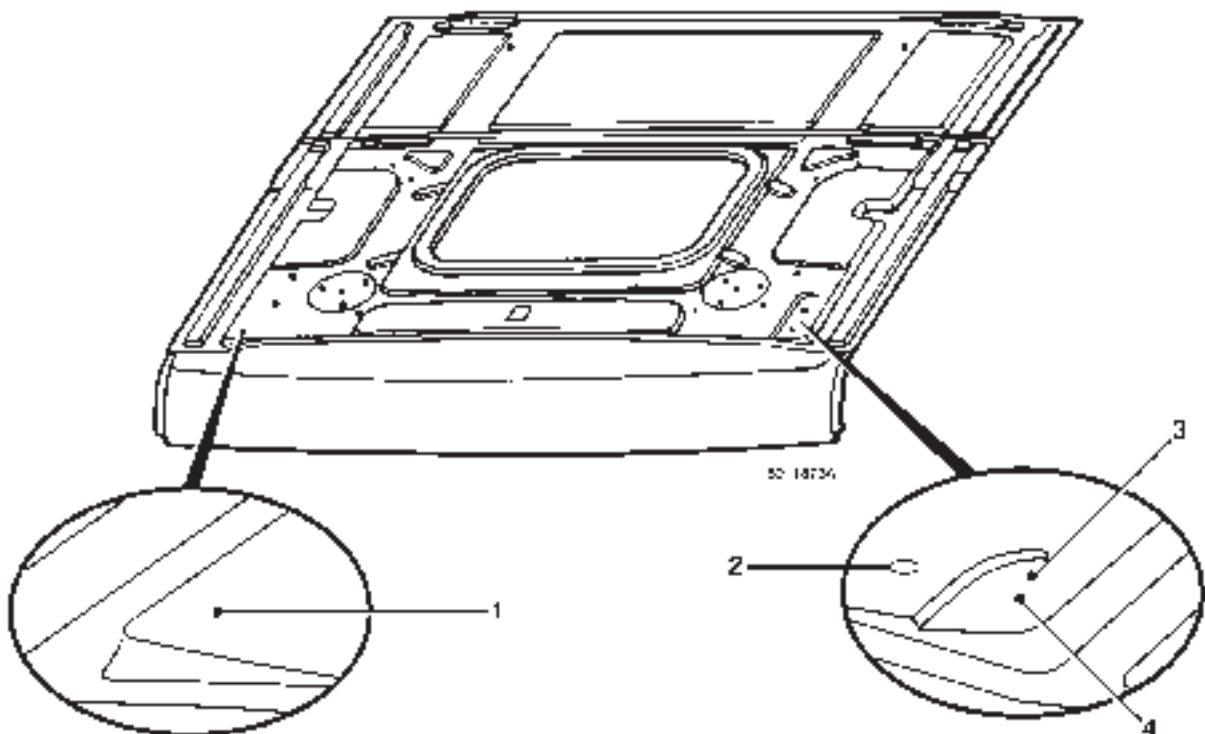

7.3.2 Installation of revolving beacons

- Wiring harness passage: at point (5), drill a hole diameter 35 mm.
- Revolving beacon fastening: at points (6), drill a hole diameter 7 mm.

The wiring harness passages must be hermetically sealed. Use a wire grommet and sealing compound, if necessary.

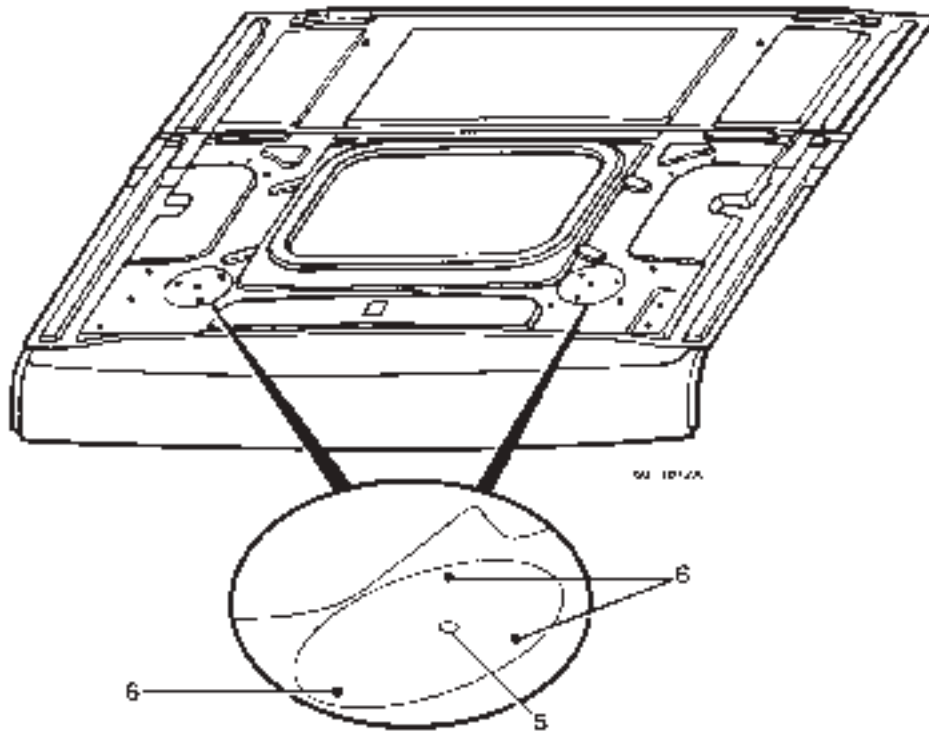

7.3.3 Installation of air horns

- Horns fastening: at points (7), drill a hole diameter 7 mm.
- Compressed air pipes passage: at point (8), drill a hole diameter 16.5 mm.

The compressed air pipes passage must be hermetically sealed. Use a wire grommet and sealing compound, if necessary.

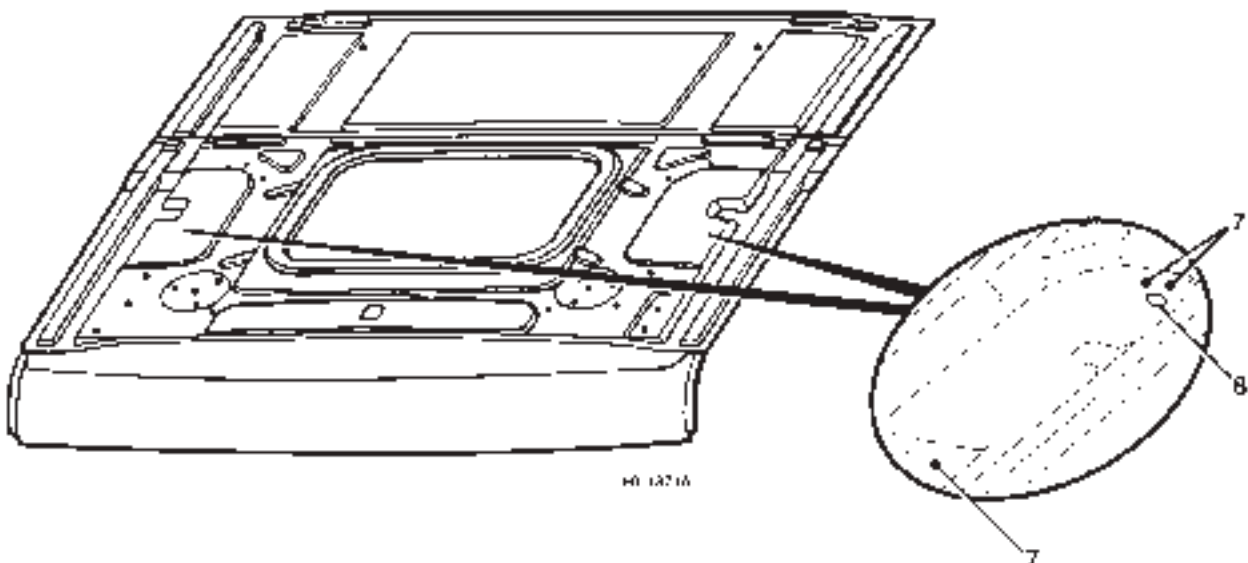

7.3.4 Installation of roof deflector

Impressions (9-10-11-12) locate the deflector fastenings. Nuts are welded to the roof stiffener if the vehicle is provided with a gantry as standard. If it is not, it is essential to use the clamping segments supplied with the deflector assembly kit. Drill holes diameter 12.5 mm at points (9-10) or (11-12).

Note

Assembly of the roof deflector is incompatible with the presence of a gantry.



Upon reception of vehicles fitted with a deflector as standard, do not forget to remove the wooden board to be found inside the deflector. This is used for transport purposes only.

Day cab

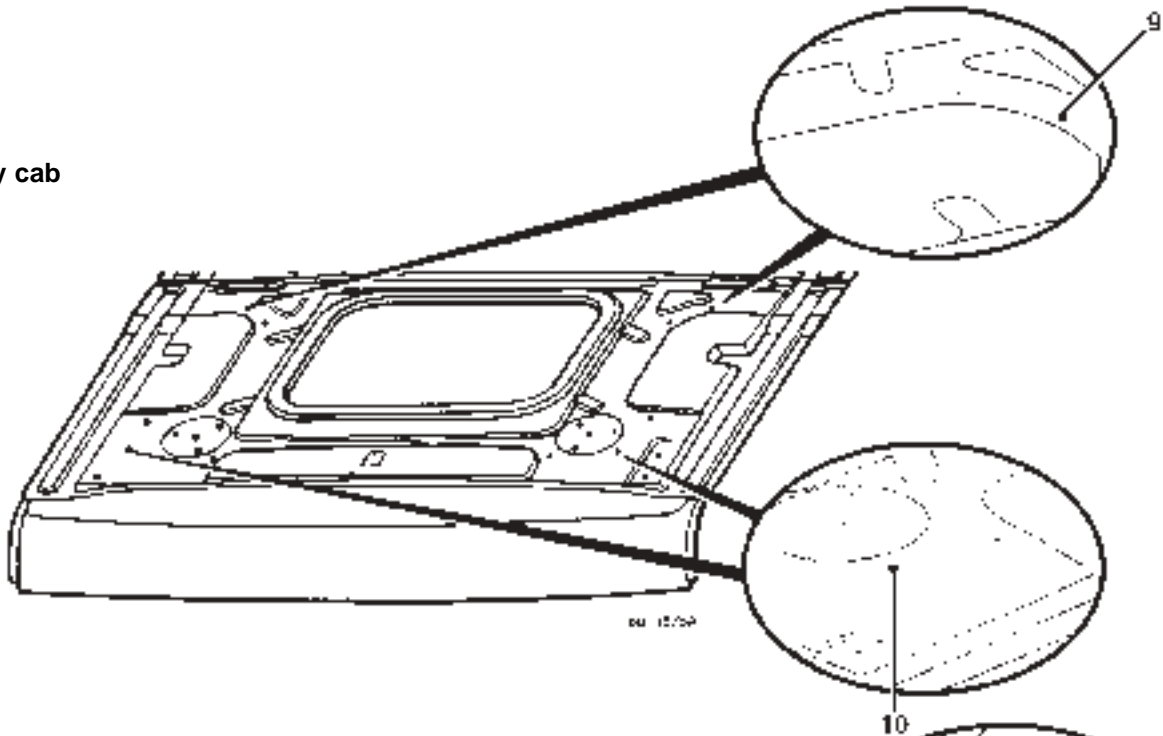

Sleeper cab

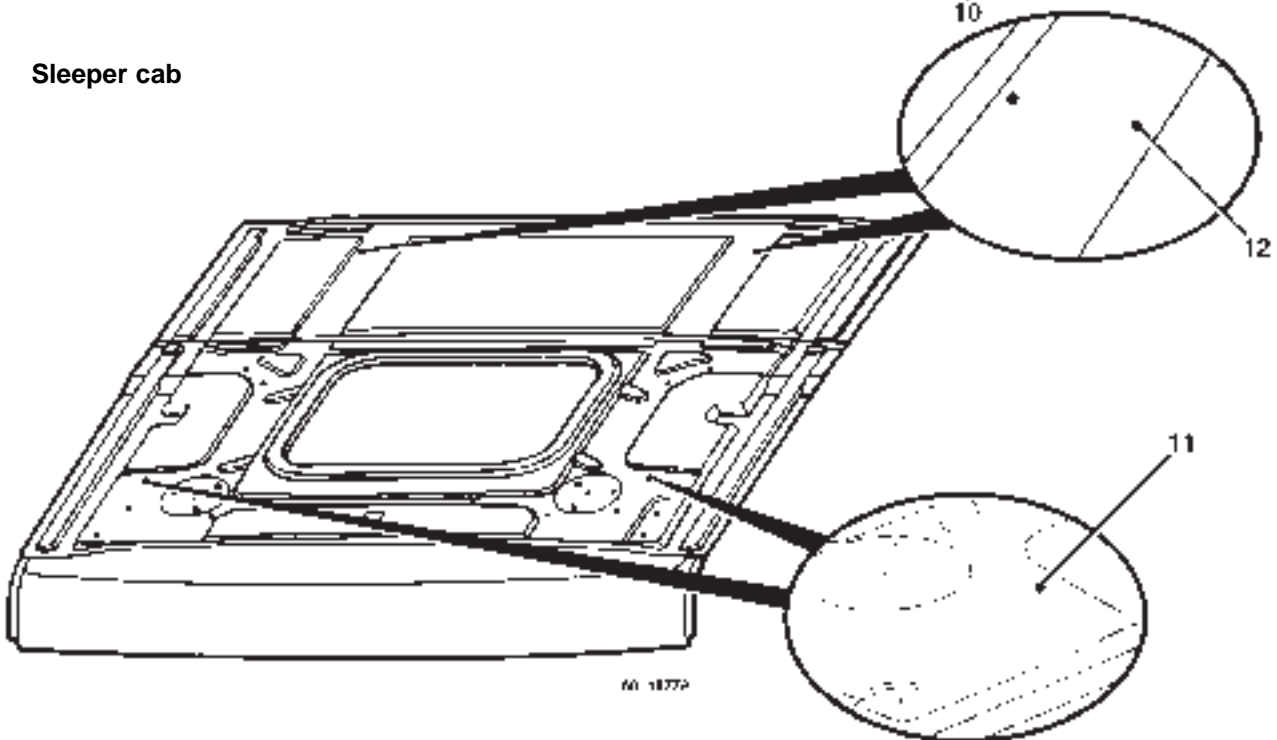

7.3.5 Installation of frontview mirror

Assembly of a frontview mirror is possible if the standard vehicle is equipped with gantry and/or sunshade. If the vehicle is equipped with gantry and/or sunshade, there already exist fastening drillings on the canopy. The frontview mirror base-plate takes the place of the gantry fixing spacer. If the vehicle is not equipped with gantry, drillings (13) must be made in the canopy. Drilling diameter: 12.5 mm.

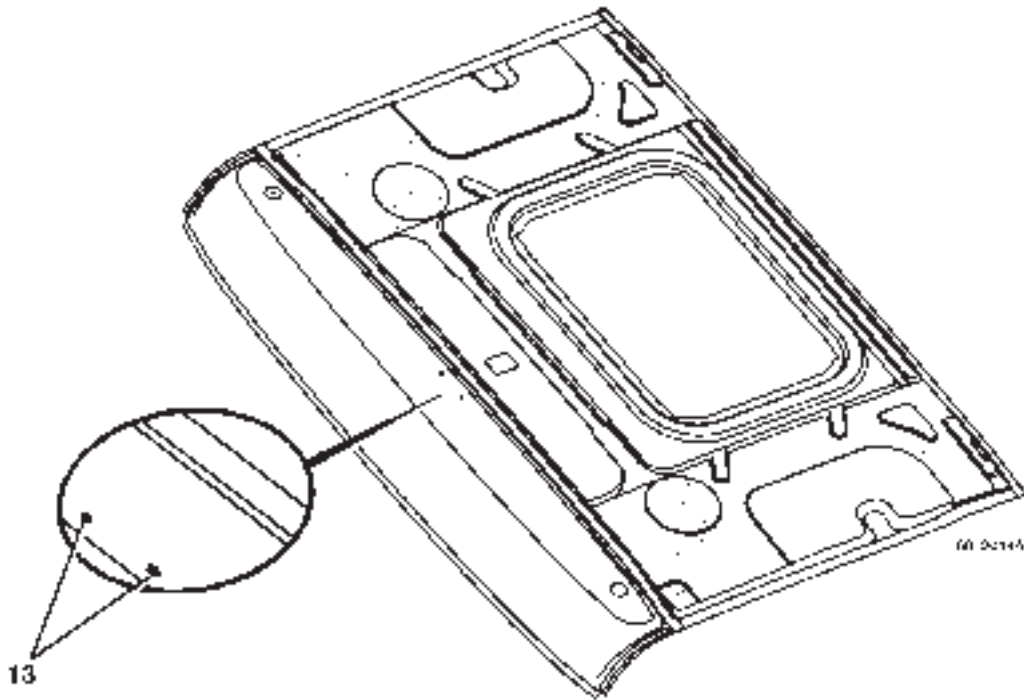

Assembly of a frontview mirror on vehicle equipped with a gantry:
The spacer (6) located on the central front fixing point (8) of the gantry is to be removed before installing the frontview mirror on the roof (9). The frontview mirror base-plate (7) plays the part of spacer.

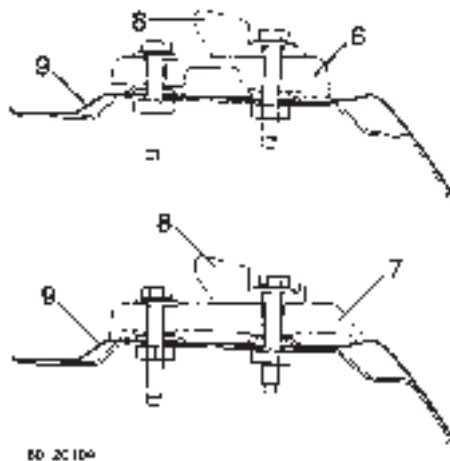

7.3.6 Installation of sunshade

Assembly of the sunshade is possible if the standard vehicle is equipped with gantry and/or frontview mirror.

Drillings to be made on the canopy:

14 - 2 drillings diameter 12.5 mm.

15 - 6 drillings for fitting sealed crimping nuts M8.

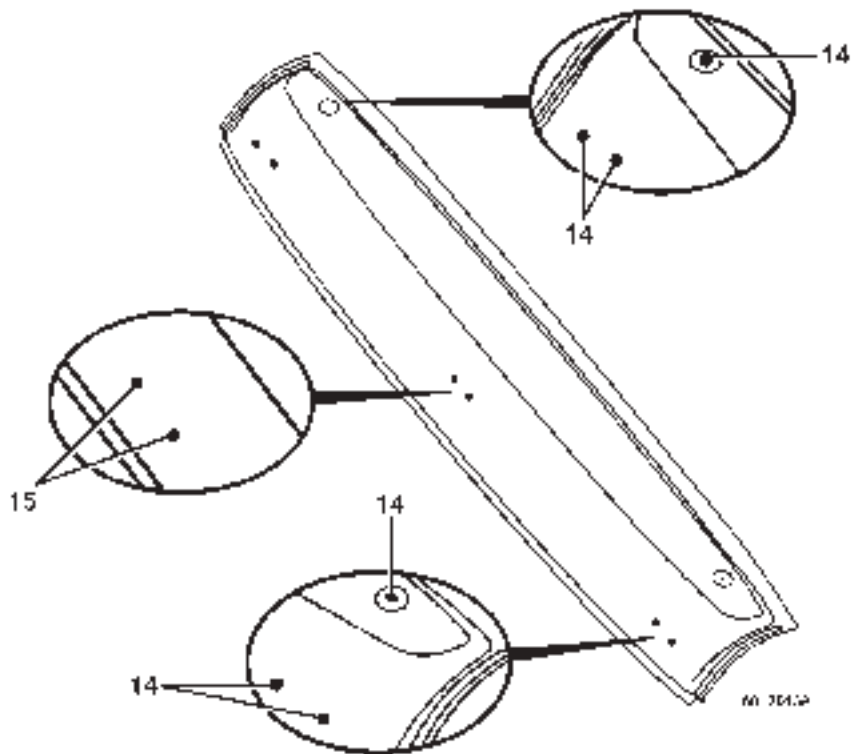

7.3.7 Installation of gantry

The gantry can only be assembled as replacement for the deflector on the following assemblies:

- deflector and sunshade,
- deflector and frontview mirror,
- deflector, sunshade and frontview mirror.

The gantry allows a maximum loading weight of 30 kg to be supported.

Fastening the gantry:

- At points (16-17), make drillings diameter 12.5 mm.

Wiring harness passage aperture:

- At point (18), make a drilling diameter 27 mm to allow passage of the wiring harness.

Passage (18) of the wiring harness must be hermetically sealed. Use a wire grommet and sealing compound, if necessary.

Note

Holes (19) already exist.

Holes (17) already exist on sleeper cabs in the case of replacement of a deflector by a gantry.

IMPORTANT

All the unused deflector fixing holes must be blanked off with M8 screws and sealing washers.

Assembly of a gantry on vehicle equipped with a frontview mirror:

Do not assemble spacer (20) as the frontview mirror base-plate (21) does the same job.

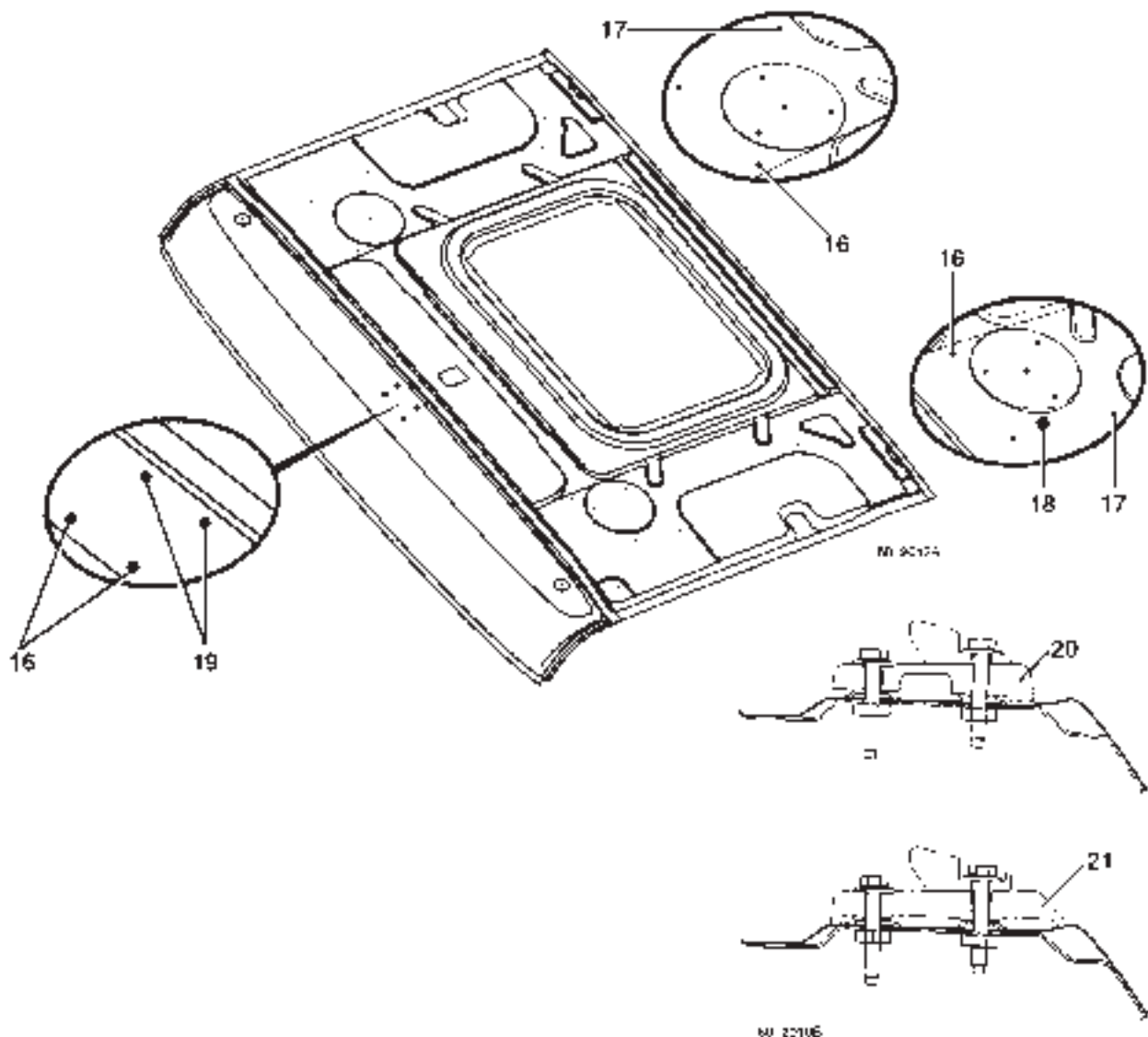

7.4 Fastening of accessories

Distribution cabs are provided with fittings on the engine tunnel for adapting various accessories.

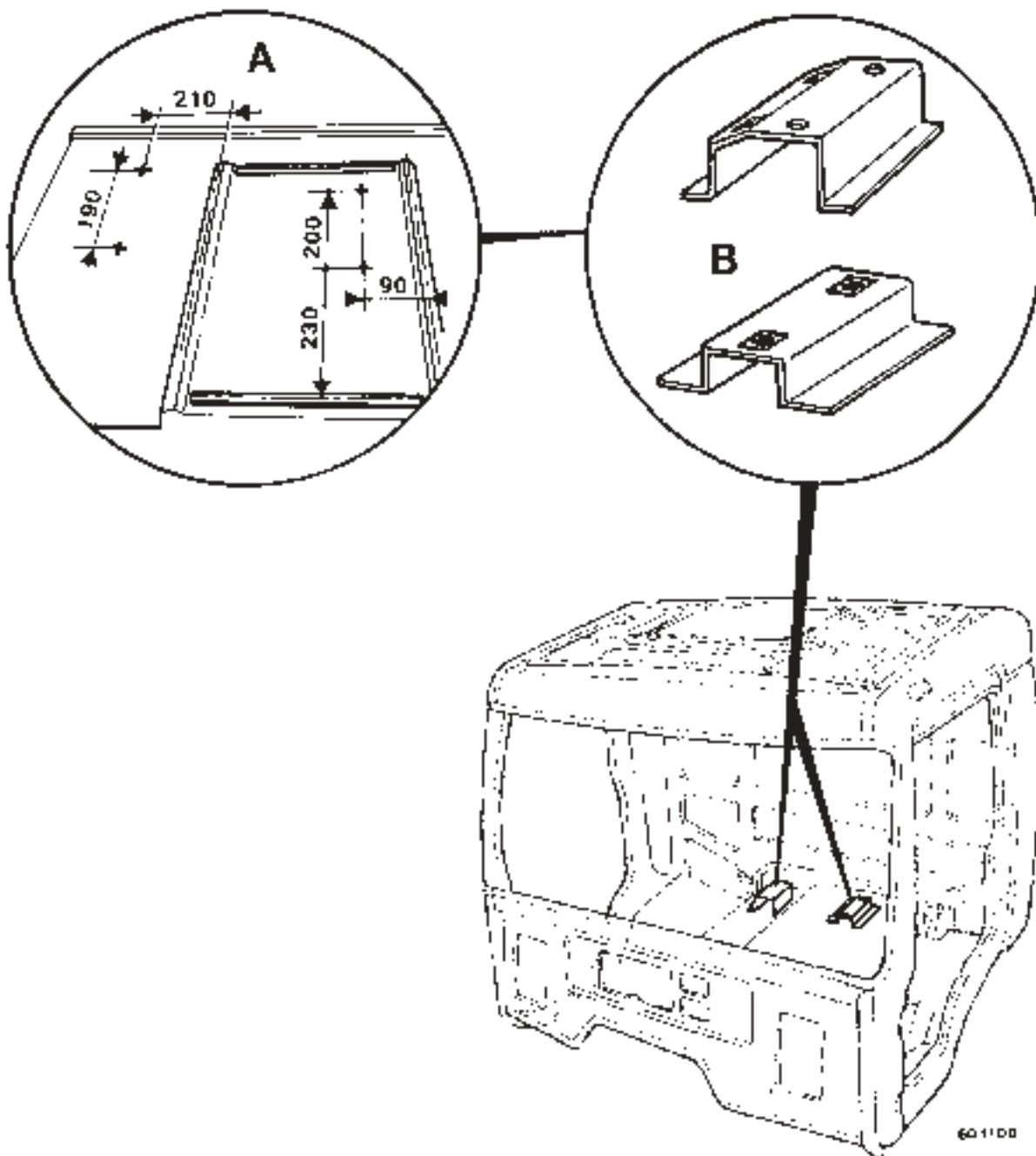

Location of fastenings

A - On the engine tunnel trim, mark and cut out the lining.

B - Fittings detail

8. AIRBAG

Depending on your vehicle's equipment

IMPORTANT

Any work on the airbag system must be carried out by qualified personnel who have undergone suitable training.

8.1 Identification of a vehicle equipped with an airbag system

A vehicle equipped with a driver's airbag can be identified by:

- the inscription "airbag" in the middle of the steering wheel.
- a sticker placed in the bottom corner of the windscreen, on the driver's side. (If the windscreen has to be replaced, affix a new sticker in the bottom corner of the new windscreen, on the driver's side).

8.2 Work on the vehicle (excluding the airbag) requiring precautions to be taken to avoid inadvertent deployment of the airbag

During repair or adaptation work, the vehicle is not to undergo any significant knocks (hammer blows...) nor is welding work to be undertaken without previously disconnecting the battery and waiting for a period of 5 minutes.

No electrical accessories should be installed, as aftermarket fitment, within the close surrounds of an airbag (loudspeaker or any other appliance generating a magnetic field might cause the airbag to release).

Before removing the steering wheel, it is essential to unplug the airbag module connector so as to avoid any damage.

In the event of any work requiring uncoupling of the steering box universal joint, the roadwheels must be in the straight ahead position and the steering wheel must be immobilized, in order to keep to the mid-point of the rotary switch.

IMPORTANT

- *If an airbag system is fitted, the seat belt must be worn.*
- *If the driver's seat designed for the airbag system has to be changed, it must be replaced by a seat identical to the one originally fitted.*
- *Adjust the seat cushion and squab correctly so that the airbag offers optimum protection.
The driver, with his back against the squab, should hold the steering wheel with his arms slightly bent.*
- *The protective cover (1) must be free from any article (ledge, clock, adhesive, various accessories...).*
- *There should be no objects within the airbag deployment area (Ø 80 cm).*
- *To avoid any inadvertent deployment of the airbag capable of causing bodily injury, it is forbidden to remove the steering wheel or work on the airbag system. Only the RENAULT V.I. network is qualified to work on the airbag system.*
- *Get the airbag system checked out in the case of accident or if there has been attempted theft of or from the vehicle.*
- *For safety reasons, replace the airbag and the pretensioner every 15 years.*
- *If water is splashed onto or gets into the electronic box located under the driver's seat, replace the box.*
- *Any significant modification to the front end of the vehicle or any overloading of the vehicle may lead to inadvertent release of the airbag system.*
- *When lending or reselling the vehicle, inform the borrower or purchaser of all these conditions. Get him to read the driving and servicing handbook.*

