

LIEBHERR
TELESCOPIC BOOM MOBILE CRANE

LTM 1030/1

single seat cabin

as of series 080

Operating instructions

BAL -No. **08100-02-02**

pages : 1 up to 373

Crane number	
Date	

The operating instructions are part of the crane!

Always keep on hand!

Comply with road travel and crane operating regulations!

LIEBHERR-WERK EHINGEN GmbH, Postfach 1361, D-89582 Ehingen / Donau
Tel. (07391) 502-0, Telex 71763-0 le d, Telefax (07391) 502-399

These operating instructions should enable you to operate the crane safely and utilize its capabilities to the fullest extent possible. They also provide notes on how important sub-assemblies and systems function.

Certain terms are used in these operating instructions, and in order to avoid misunderstandings while operating, these terms should be used consistently.

**D A N G E R : Only qualified and especially trained personnel may work on this crane!
If this is not assured, the change of causing a serious accident is greatly increased!**

All regulations and guidelines applicable to the job site, such as accident prevention regulations and all guidelines and regulations stated in the Operation Manual must be strictly adhered to.

All accident prevention and operating guidelines and regulations, etc. assume that the crane is strictly used for lifting and transporting of loads. Any other application or use does not constitute "specified and proper use". Any risks associated with unspecified or improper use are the sole responsibility of the crane's owner, operator or user.

Using these instructions

- **makes it easier** to become familiar with the crane
- **avoids** malfunctions due to improper operation

Observing these instructions

- **increases** reliability in operations
- **increases** the operating life of the crane
- **reduces** repair costs and down-time

Always keep these operating instructions handy in the driver's and crane cab - they are an integral part of the crane!

Operate this crane only with a thorough knowledge of its capabilities and limitations and in strict observance of these instructions.

If you receive further information on the crane from us, e.g. in the form of technical information letters, this must be observed and filed with the operating instructions.

If there are parts of these instructions or individual chapters that you do not understand, please do not hesitate to ask us before you begin operation - we are glad to answer any inquiries you may have.

No part of these operating instructions may be circulated, nor may they be used for the purposes of competition. All rights expressly reserved according to copyright law.

These operating instructions are to be read and the information in them is to be observed by all persons operating, maintaining, or otherwise working in any capacity on this crane.

Notes

Throughout these instructions, the terms "Note", " C A U T I O N " and " D A N G E R " occur - these refer any persons working with the crane to IMPORTANT OPERATING METHODS that must be observed.

Note: The term "Note" is used whenever the observance of certain instructions or notes is economically meaningful to the utilization of the crane.

C A U T I O N : The term " C A U T I O N " is used whenever damage to the crane can occur if the operating instruction(s) is not observed and adhered to.

D A N G E R : The term " D A N G E R " is used whenever the nonobservance of the warning given may injure or lead to the death of persons and damage to the crane.

Safety devices

The safety devices integrated into the crane system deserve your special attention. They must always be checked to see that they are functioning properly. If they do not function or function incorrectly, the crane may not be operated. Your motto should always be:

" S A F E T Y F I R S T "

CONTENTS

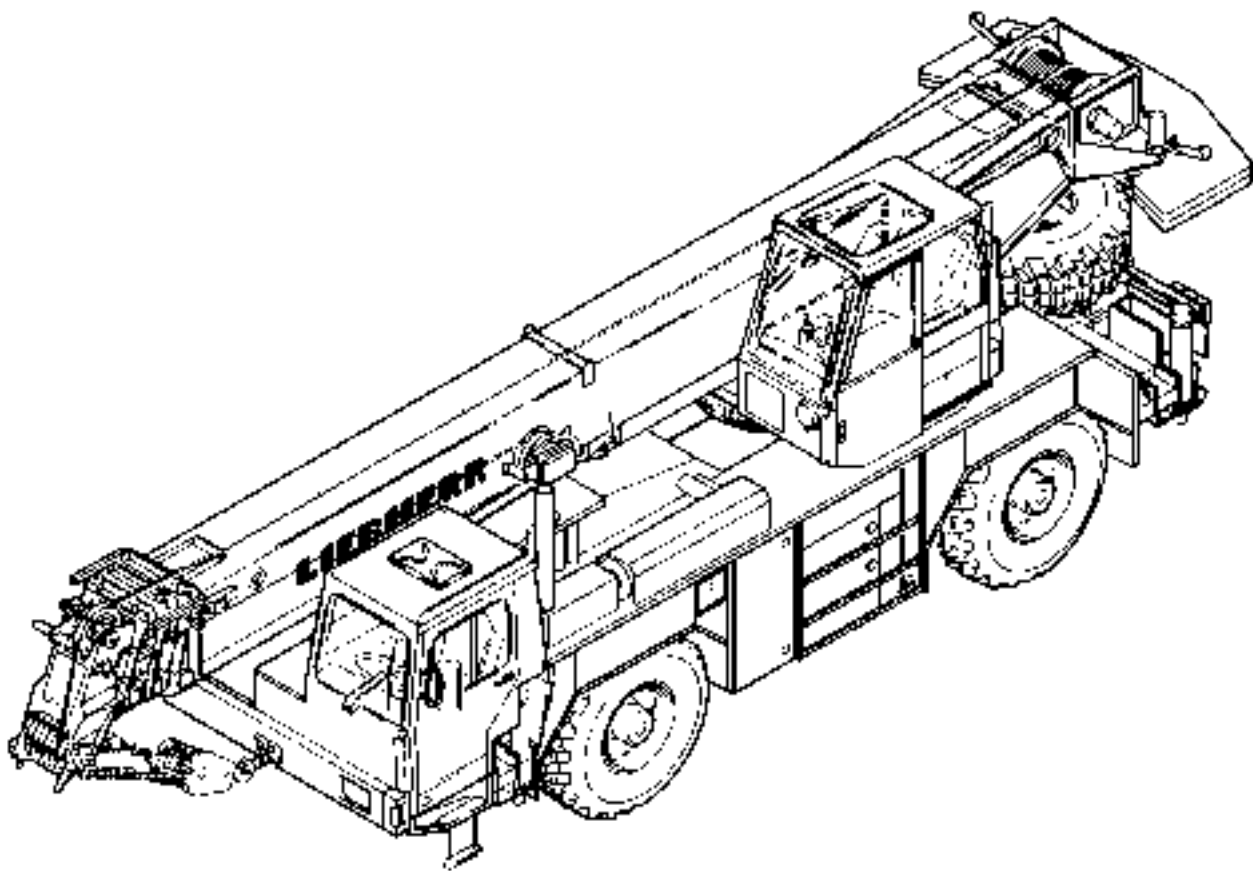

183016

CONTENTS

1.00	DESCRIPTION OF THE CRANE	8
1.01	TERMINOLOGY	10
1.02	PRODUCT DESCRIPTION	16
1.03	TECHNICAL DATA	18
2.00	SAFETY	22
2.01	ROAD TRAFFIC REGULATIONS	24
2.02	INSTRUCTIONS ON RUNNING-IN	28
2.03	OPERATIONAL PLANNING	30
2.04	SAFETY-TECHNICAL NOTES	32
3.00	OPERATION OF THE CHASSIS	50
3.01	OPERATION AND CONTROL INSTRUMENTS - VEHICLE	52
3.02	BEFORE STARTING UP THE VEHICLE	60
3.03	AXLE SUSPENSION/LOCKING SYSTEM	72
3.04	DRIVING ON PUBLIC ROADS	78
3.05	THE CRANE AT THE OPERATING SITE	106
4.00	OPERATION OF THE SUPERSTRUCTURE	124
4.01	CONTROLS AND INSTRUMENTS	126
4.02	CONTROL + INDICATOR UNIT FOR "LICCON" OVERLOAD SAFETY DEVICE	134
4.03	STARTING UP THE CRANE	140
4.04	SAFETY DEVICES	152
4.05	CRANE OPERATION	160
4.06	REEVING	178
4.07	BALLAST	188
4.08	WORKING WITH A LOAD	194
4.09	DRIVING WITH THE ATTACHMENT IN PLACE	204
4.10	DRIVING FROM THE CRANE OPERATOR`S CAB	212
4.11	CRANE OPERATION "FREE-STANDING"	228
4.12	TWO-HOOK OPERATIONS	230

CONTENTS

CONTENTS

5.00	EQUIPMENT	236
5.01	SAFETY-TECHNICAL NOTES	238
5.02	FOLDING FLY JIB - TK	242
5.13	CRANE OPERATION WITH AERIAL PLATFORM	262
6.00	ADDITIONAL EQUIPMENT	264
6.01	HEATING / ENGINE PREHEAT SYSTEM	266
6.02	EMERGENCY ACTIVATION	280
6.03	RECOVERY	290
7.00	SERVICE AND MAINTENANCE	292
7.01	SERVICING AND MAINTENANCE	294
7.02	MAINTENANCE INTERVALS FOR CRANE CHASSIS	298
7.03	MAINTENANCE INTERVALS FOR CRANE SUPERSTRUCTURE	306
7.04	MAINTENANCE INSTRUCTIONS - CHASSIS	310
7.05	MAINTENANCE INSTRUCTIONS - SUPERSTRUCTURE	322
7.06	LUBRICATION CHART, FILLING CAPACITIES	328
7.07	SCHMIERSTOFFTABELLE	330
8.00	CRANE INSPECTIONS	334
8.01	REPEAT CRANE INSPECTIONS	336
8.04	INSPECTION OF CRANE CABLES	350
8.07	INSPECTION OF PNEUMATIC BRAKE SYSTEM	360
9.00	GENERAL NOTES	364
9.01	CODE OF PRACTICE FOR OVERLOAD SAFETY DEVICES OF BOOM CRANES	366
9.02	GUIDELINES TO PREVENT FIRES IN THE ENGINE AREA AND IMPORTANT SERVICE WORK TO BE PERFORMED	368

Chapter 1

Description of the Crane

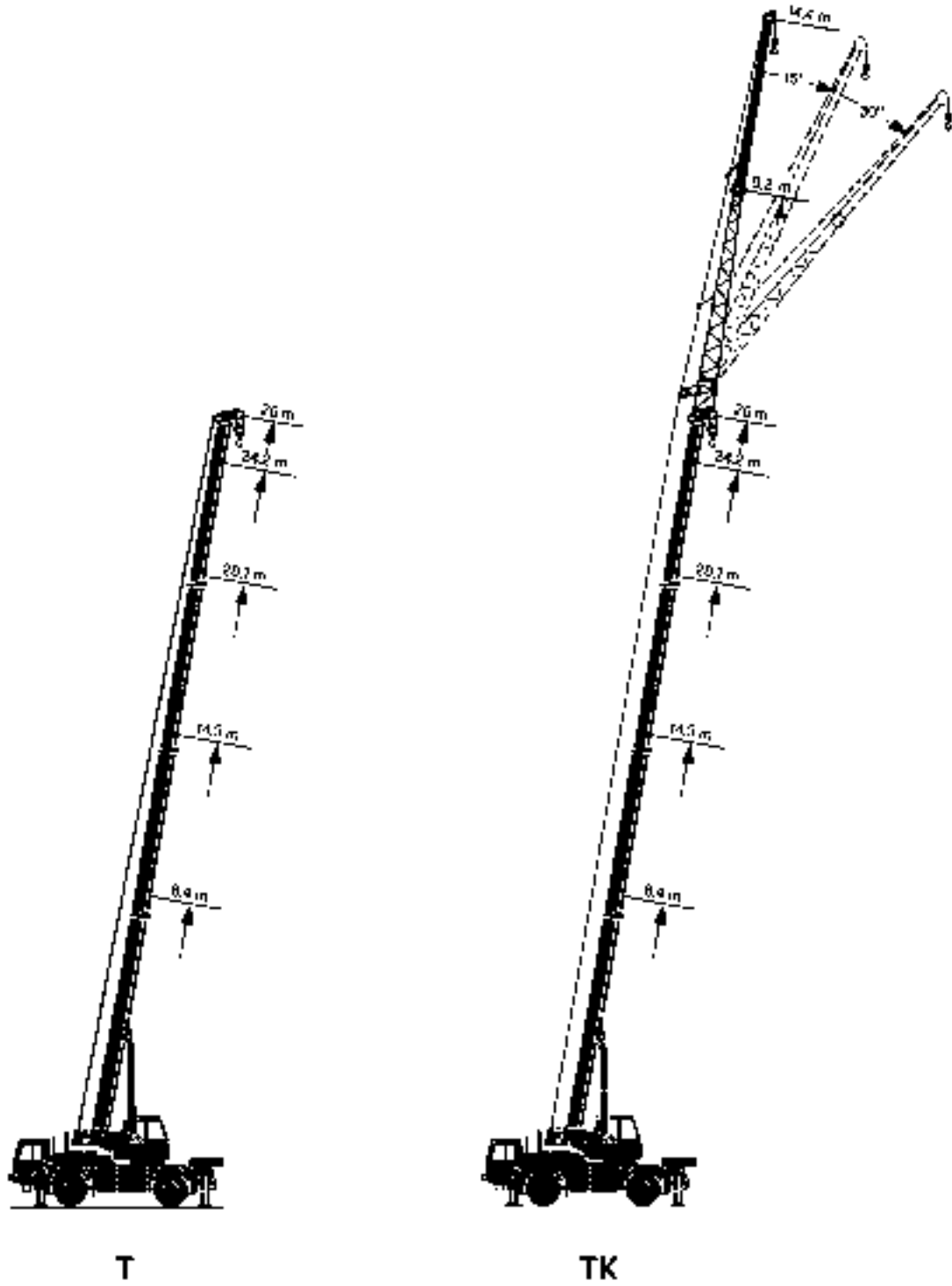

Abbreviations for the boom system

T = telescopic boom

TK = telescopic boom with folding fly jib 0°/ 15°/ 30°

Boom combination:

T - boom combination T = 8.4 m to 26 m

TK - boom combination T = 24.2 m + K 8,2 m
T = 24.2 m + K 14,4 m
T = 26,0 m + K 8,2 m
T = 26,0 m + K 14,4 m

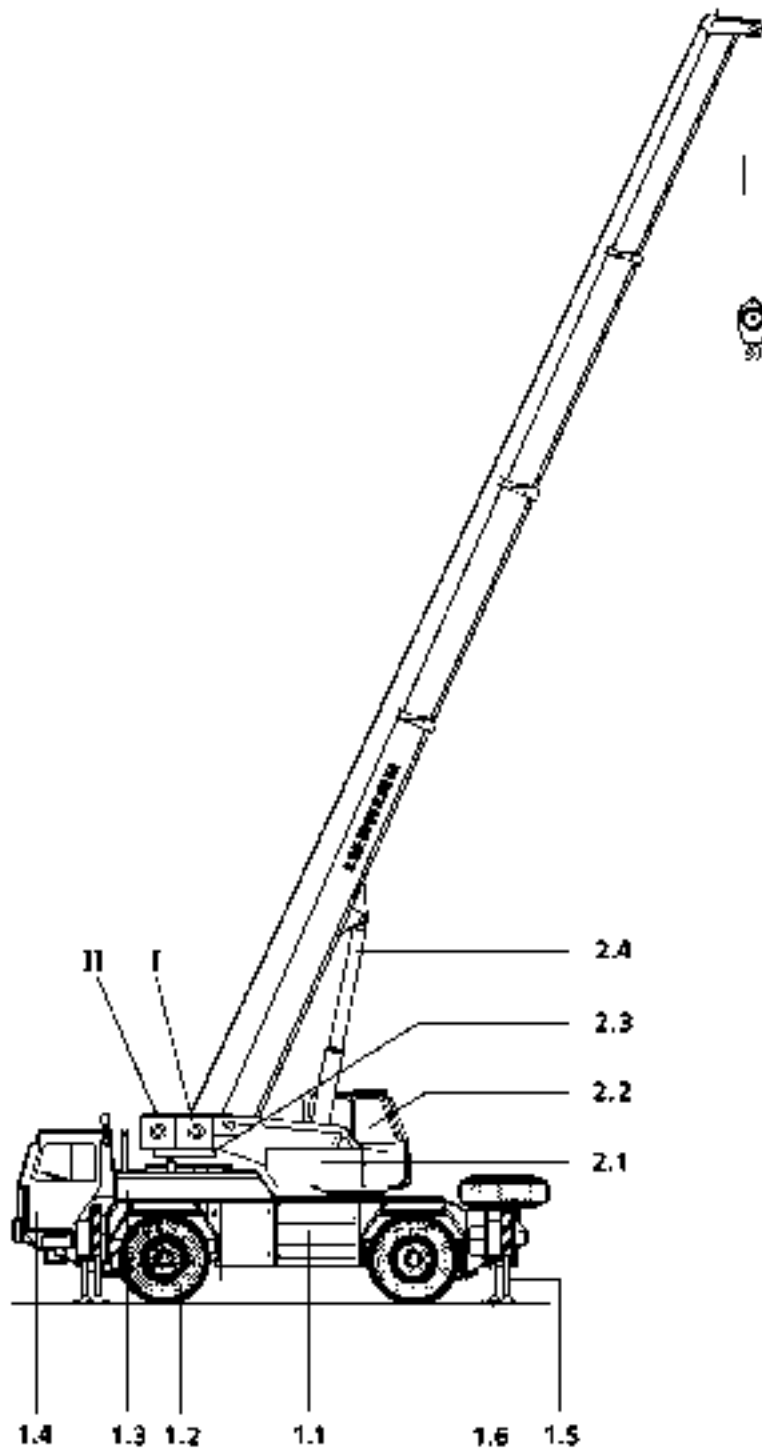

1 Crane chassis

- 1.1 2-axle chassis
- 1.2 Tires - individual tires on axles 1 and 2
- 1.3 Diesel motor with on-load shift gearbox
- 1.4 Driver's cab
- 1.5 Sliding arm with support jack
- 1.6 Support pads

2 Crane superstructure

- I Winch I Hoisting gear for T, TK operations
- II Winch II Hoisting gear for T, TK operations

- 2.1 Control block
- 2.2 Crane operator's cab
- 2.3 Ballast
- 2.4 Telescopic boom adjustment - luffing jack

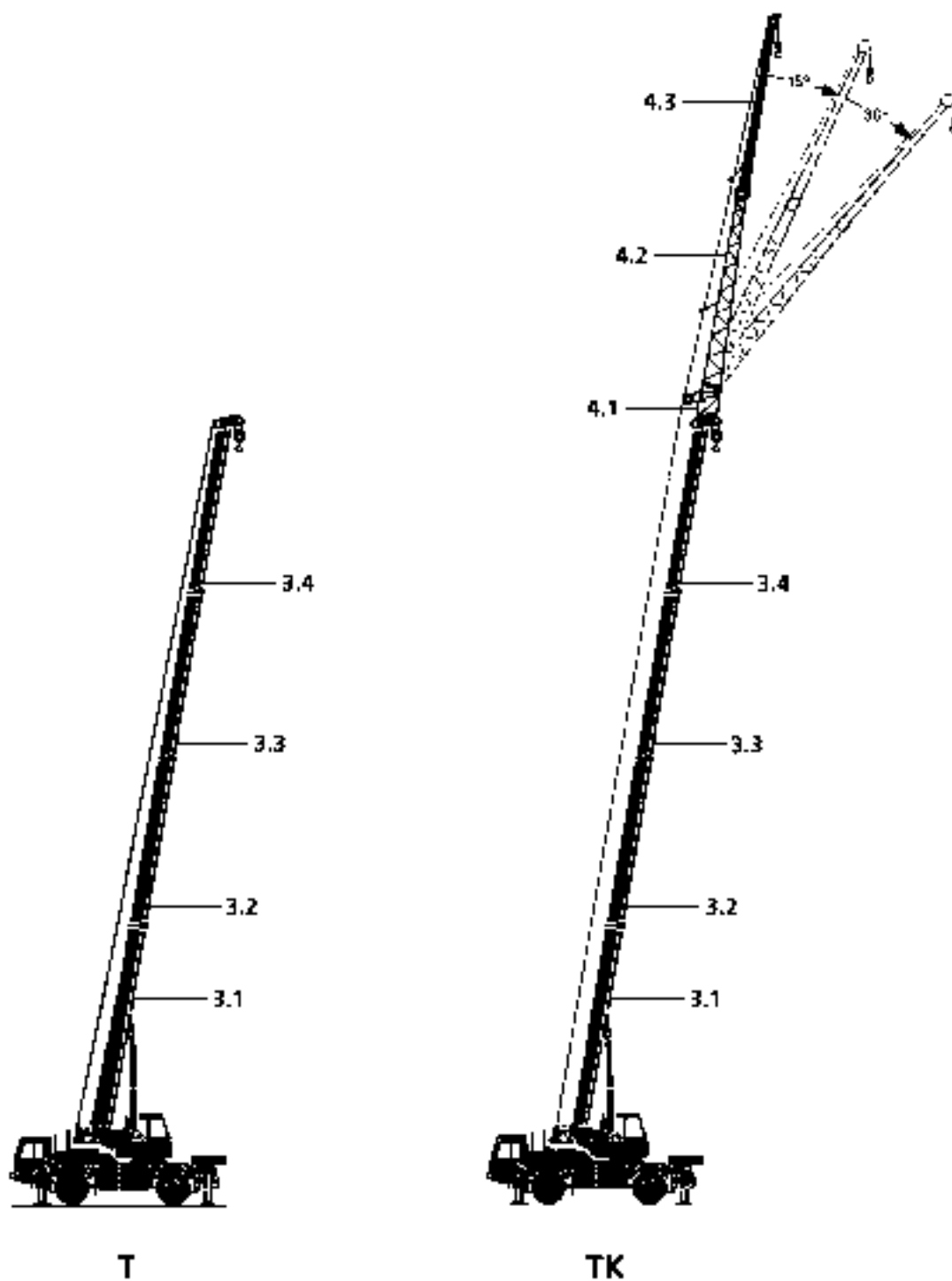

3 Telescopic boom T

3.1 Pivot section

3.2 Telescope section 1

3.3 Telescope section 2

3.4 Telescope section 3

4 Telescopic boom with folding fly jib TK

4.1 Adapter for assembling the folding fly jib below an angle of 0° / 15° and 30°

4.2 Folding fly jib 8.2 m

4.3 Double folding fly jib 8.2m and 14.4m

The crane carrier

- Frame:** Liebherr designed and manufactures, box type, torsion resistant, all-welded construction made of high -tensile structural steel.
- Outriggers:** 4 point support, all hydraulic vertical and horizontal operation.
- Engine:** Diesel, 6 cylinder, made by LIEBHERR, Type D 916 TI, water cooled, output per DIN: 180 kW (245HP) at 2100 RPM, acc. to ECE 24.03, max. torque 1020 Nm at 1300 RPM.
Fuel tank capacity: 300 l.
- Gearbox:** Powershift gear with torque converter and lock-up ,
6 forward and reverse speeds, additional activation of front wheel drive.
- Axles:** Front: Planetary axle with differential lock, steerable.
Rear: Planetary axle with differential lock, steerable, lockable for on road travel.
- Suspension:** Hydro pneumatic suspension, lockable hydraulically.
- Tires:** 4 tires, tire size : 14.00 R 25.
- Steering:** Front axle: Mechanically steered with hydraulic power assistance and stand-by steering pump.
Rear axle: Hydraulically steered.
Both axles steered hydrostatically from crane cab.
Steering acc. to EC directive 70/311/EEC
- Brakes:** Service brake: 2 circuit air booster brake acting on all wheels.
Hand brake: Spring loaded, acting on all wheels.
Brakes acc. to EC directive 71/320/EEC
- Cab:** Made of galvanized steel sheeting, located at the side of the carrier above the front axle.
With controls and instruments for driving.
- Electr. System:** 24 V DC, 2 batteries, lighting according to local regulations.

The crane superstructure

- Frame:** Liebherr made, torsion resistant, welded construction made of high tensile structural steel. Connection to truck chassis by single row ball slewing ring , designed for 360° continuous rotation.
- Hydraulic system:** 1 axial variable displacement piston pump and 1 triple gear pump in the crane carrier, driven by Diesel engine, open hydraulic circuits with "load sensing", simultaneous operation of 4 working movements.
- Crane control:** By 2 self centering manual joystick type control levers in the crane cab and by speed variation of the Diesel engine.
- Hoist gear:** Axial piston fixed displacement motor, hoist drum with integrated planetary gear and spring loaded static brake.
- Luffing gear:** 1 differential hydraulic cylinder with pilot locking valve.
- Slewing gear:** Hydraulic motor, planetary gear with spring loaded static brake. Continuous control of slewing speed.
- Crane cab:** Fully galvanized steel construction, safety glazing, control elements and instruments for crane and travel operation.
- Safety devices:** LICCON overload indicator, hoist limit switch, safety valves against pipe and hose ruptures.
- Telescopic boom:** 1 boom pivot section and 3 telescopic sections. All sections hydraulically extendible under load.
Boom length: 8.4 m to 26 m.

Additional or alternative equipment

- Folding jib:** Single folding jib 8.2 m long, installation at 0°, 15° or 30° angle to the telescopic boom.
Double folding jib 8.2 m and 14.4 m long, installation at 0°, 15° or 30° angle to the telescopic boom.
- 2nd hoist gear:** For two hook operation, or with folding jib in case main hoist rope is to remain reeved
- Tires:** 4 tires, tire size: 17.5 R 25.
- Divided cab:** Removable upper part to increase overhead clearance.

Measurements**Weights**

- Axle loads
- Lifting tackle

Working speeds

- Travel speeds
- Crane speeds

Lifting heights

- Telescopic boom
- Lattice jib

Tires

Tire size	Tire weight [kg]	Tire pressure for travel on public highways [bar]	Tire pressure for crane operation » free on tires « [bar]
14.00 - 25	245	10	according to load capacity chart » free on tires «
17,5 - 25 *	270	7	according to load capacity chart » free on tires «

Emission values at the work place

Sound levels at nominal engine RPM	Stationary sound L_{pAeq} [db(A)]	
	left ear	right ear
Driver's cab, driver's side	73	75
Crane operator's cab	78	79

* optional

Die Maße. Dimensions. Encombrement.

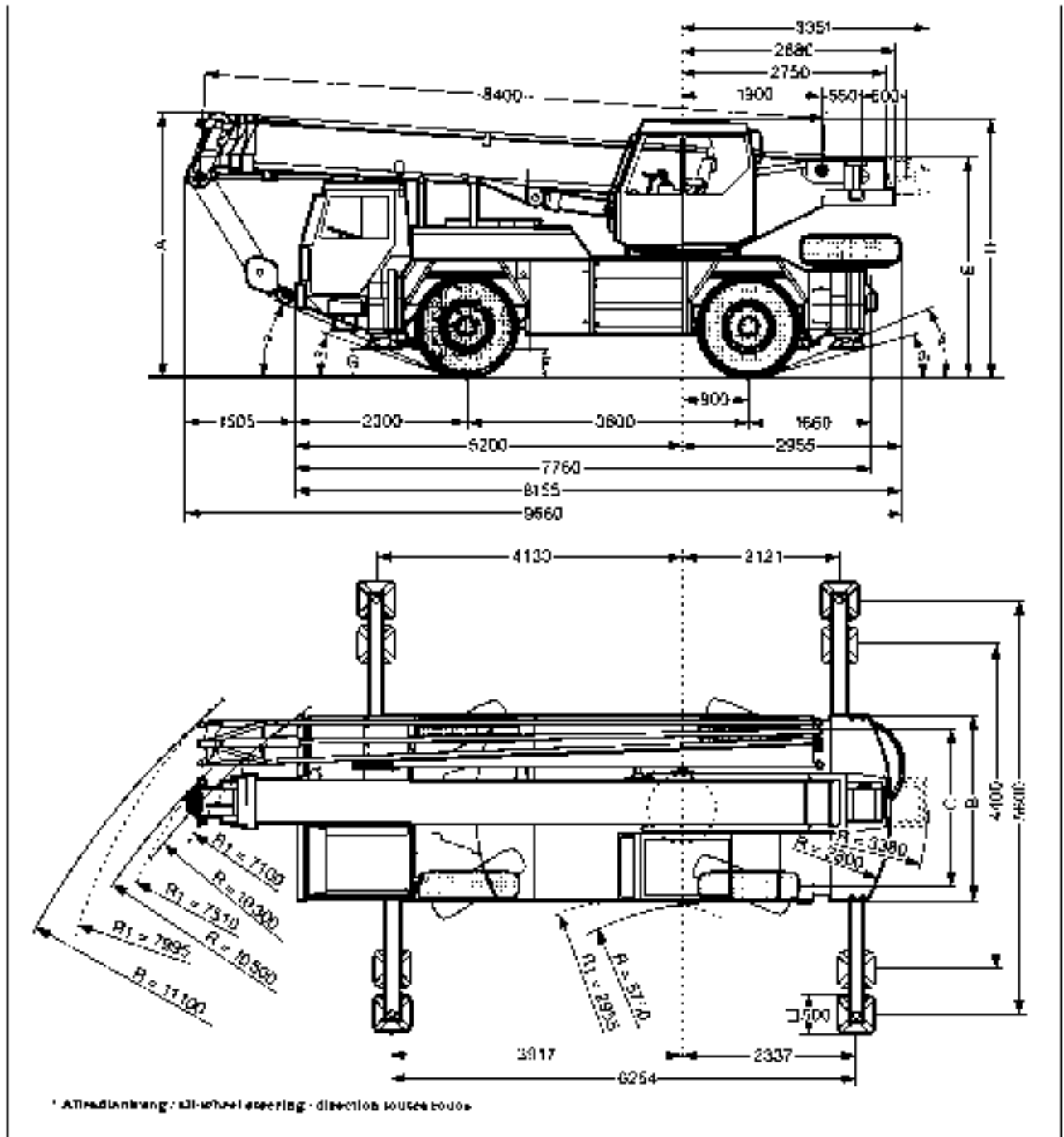

Bezeichnung Types Pneumatiques	Maße / Dimensions / Encombrement mm												
	A	A ⁺	B	C	D	E ¹⁾	F	G	α	α ₁	β	β ₁	
14.00 R 25	3540	3440	2500	2114	3440	4850	380	440	23°	15°	23°	15°	
17.5 R 25	3540	3440	2800	2164	3440	2850	380	440	23°	15°	23°	15°	

¹⁾ 100 mm abgesenkt
100 mm lowered
abaissé 100 mm

²⁾ abgesenkt und ohne Kablenabstreifer
lowered and without upper part of cab
abaissé et sans partie supérieure de cabine

**Die Gewichte.
Weights.
Poids.**



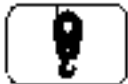

**Die Geschwindigkeiten.
Working speeds.
Vitesses.**





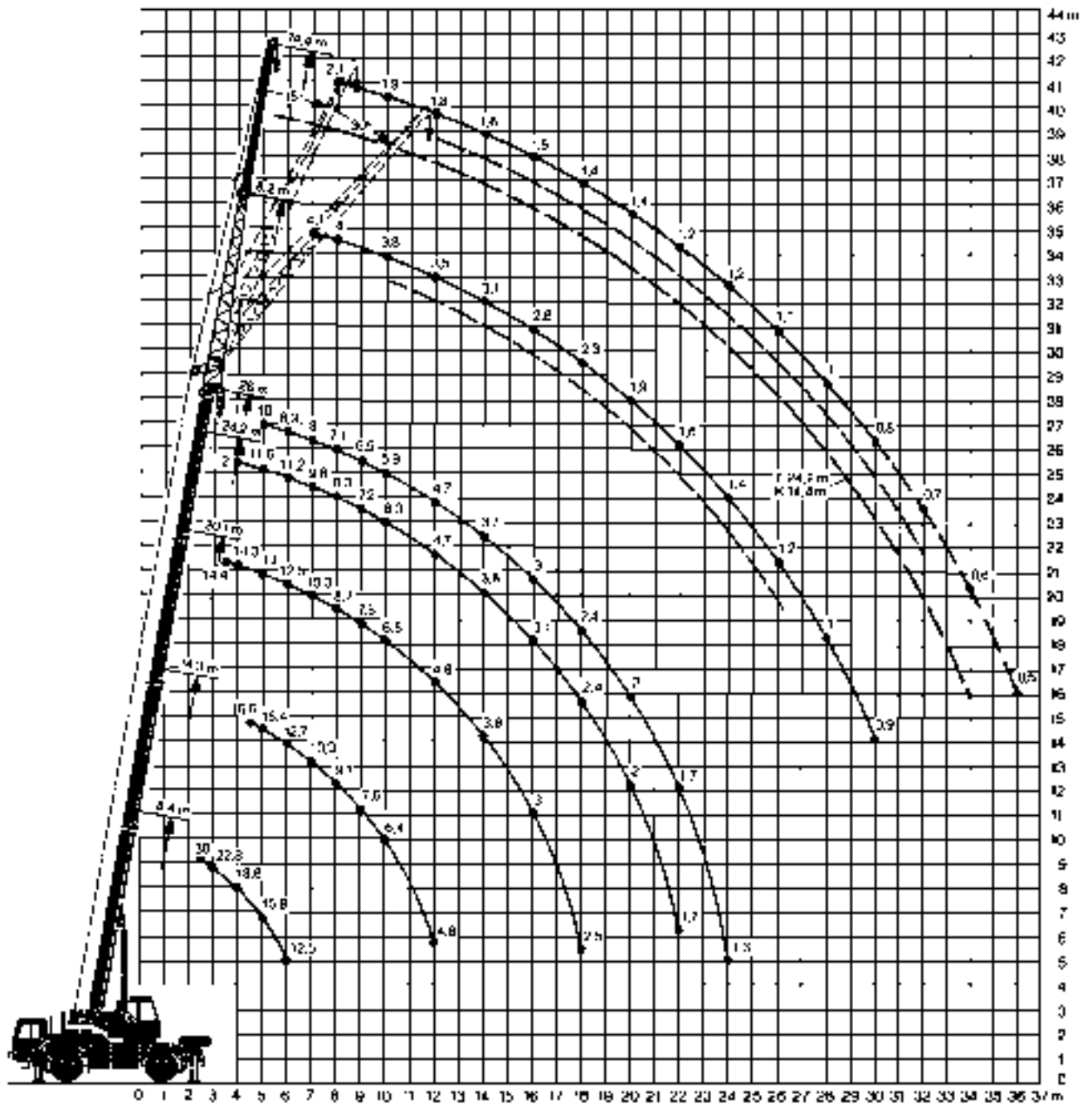

Chapter 2

Safety

Road traffic regulations

The crane is approved as a road vehicle within the context of regional traffic regulations.

It must be ensured that the weight, axle loads and dimensions given in approval certificates are observed and are not exceeded.

D A N G E R : **If axle loads and overall weight exceed the permissible limits, braking power will be reduced in proportion to the excess weight involved.**

The service brake, parking brake and retarder will then no longer conform to regulations.

Travel with the crane according to the **national road traffic regulations**.

Carrying passengers in the crane cab is **not** permitted.

Instructions on running-in

CAUTION: The crane is not yet running-in

For this reason, the following instructions must be followed:

- 1.) During the first 2000 km (1,240 miles), the mobile crane **must not** be driven at more than 3/4 of its maximum speed in each gear (engine speed = max. 1900 rpm)
 - Full throttle is permitted only briefly when driving or traffic conditions demand.
 - At the end of the running-in period, gradually increase to full power operation.
- 2.) The oil pressure and temperature gauges must be monitored constantly while driving!
 - If either gauge shows an excessive reading, stop operation immediately.
- 3.) Carry out the following service operations after the first 50 and the first 100 kilometres (30 and the first 60 miles) of operation.
 - Check that wheel nuts are tightened securely.

CAUTION: Do not overtighten wheel nuts!
(max. permitted tightening torque = 600 Nm; 445 ft-lb).

- Check coolant and oil levels in the engine.
- Check oil level in power-shift (Hi-Lo) or automatic transmission.
- Check engine, transmission and axle mountings for secure seating and for leaks (visual check).
- Check drive shafts for secure connection.
- Check all other chassis components for secure mounting.
- Check air pressure and conditions of the tyres (visual check).

Breaking in the brake pads

In order to obtain optimum braking acting, new brake pads must be activated or broken in. Brake in the new pads by applying the brakes in intervals in low to medium speed range, do not brake forcefully! The braking in route - preferably at least 500 km (310 miles) depends on the vehicle. In this phase, the maximum brake drum or brake disk temperature of 200 °C (392 °F) may not be exceeded. The increase in temperature resulting from each individual braking action may not exceed 15% of the maximum value.

CAUTION: DO NOT break in new brake pads through one or more continuous braking actions over a longer period of time or by applying the brakes forcefully while driving at high speed.

DANGER: If this point is not strictly observed, you could cause a serious accident!

Operational planning

As well as a fully functioning crane and well-qualified personnel, **operational planning** is an important precondition for safe and reliable crane operation.

The crane operator must be in possession of or procure all the necessary information before starting the crane operation, especially:

- Nature of work
- Site location (journey distance)
- Route to be driven
- Height and side clearances
- Electrical overhead wires (complete with voltage data)
- Space requirements at the operating sites
- Movement restrictions due to surrounding structures
- Weight and dimensions of load(s) to be lifted
- Required lifting height and radius
- Load-bearing capacity of soil or surface to be operated upon

The crane operator can then use this information to decide on the correct crane operating equipment:

- Hook blocks/load blocks
- Auxiliary telescopic boom
- Lifting / slinging tackle
- Counterweight
- Underlay material for support pads

DANGER: If the crane operator does not possess all necessary and required information, it may prove impossible to carry out the intended work, or he may be tempted to improvise - and accidents may be the result!

Requirements of the crane operator

The most important requirement of the crane operator is to control, operate and adjust the crane so that there is no danger to the crane crew and/or third parties.

In order to fulfil this requirement, we would like to give you in the following a few important safety notes.

65% of all accidents involving vehicle cranes is due to improper crane operation.

Improper operating procedures most often carried out are:

Not paying careful attention while working in the case of, for example:

- slewing too quickly,
- quick braking of the load,
- cross pulling,
- loose cable formations

Overloading

Driving too fast with a load, or setting up and loading on an uneven surface.

Improperly slinging a load.

Operating in unsuitable conditions, especially pulling at an angle or fixed loads coming loose.

Wind on suspended load.

Improperly driving on public roads without a load, for example, engine or transmission overloaded.

Collision with bridges, ceilings, high-voltage wires.

Insufficient support; support base beneath the supports not sufficient in capacity.

Improper assembly/disassembly of telescopic booms.

20% of all accidents involving cranes are due to improper maintenance:

- Lack of oil, grease or antifreeze
- Accumulation of too much dirt
- Broken cables, defective tires, worn parts
- Emergency limit switch or load torque limiter not operational
- Brake and/or transmission failure
- Defects in the hydraulic systems; for example, tears in hoses
- Loose screws

DANGER: In your interest and in the interest of others, please learn to command your crane thoroughly and familiarize yourself with all the dangers associated with the work to be carried out.

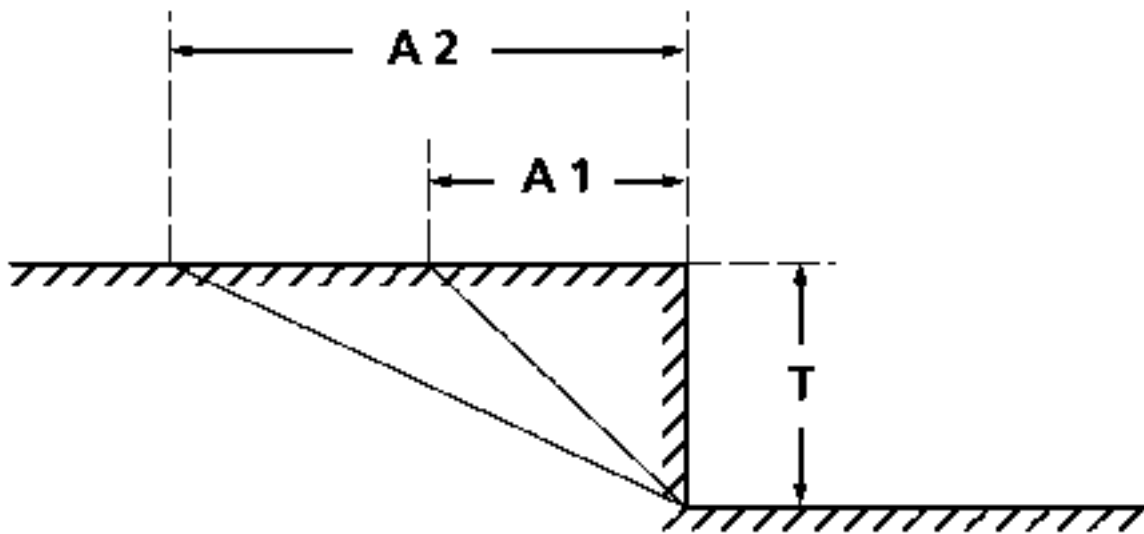

Selecting an operating site

To avoid accidents from the outset, the correct selection of an **operating site** is extremely important.

The operating site should be selected so that:

- the supports can be extended to the points prescribed in the load capacity tables.
- crane operations can be carried out within the smallest possible **radius**.
- no obstacles hinder necessary movements.
- the ground at the operating site is able to support expected loads.

DANGER: **The most important requirement for safe crane operation is working on firm ground with the capacity to support your loads.**

Slopes and trenches

The crane must not be set up too close to slopes or trenches and depending on the type of soil, a safe distance must always be kept from them.

Note: Safe distance is measured from the foot of the trench and is:

- soft or backfilled soil = 2 × depth of trench (A2 = 2 × T)
- hard or grown soil = 1 × depth of trench (A1 = 1 × T)

DANGER: **If a safe distance can not be kept, the slope or trench must be firmly filled. Otherwise, there is a danger that the edge of the slope or trench will give way.**

Permissible ground-bearing load

When the crane is supported, the supports exert considerable pressure onto the ground. In certain cases, individual supports must take up the weight of the crane as well as the weight of the load and this is transferred to the ground.

The ground must always be able to stand up to the pressure exerted upon it. If the surface area of the support pads are not sufficient, these must be fixed with a foundation corresponding to the load-bearing capacity of the ground. The necessary supporting surface can be calculated from the load-bearing capacity of the ground and the supporting pressure of the crane.

$$\text{Required supporting surface} = \frac{\text{Support pressure}}{\text{Load-bearing capacity of the ground}}$$

Permissible ground-bearing load

Type of Soil	[daN / cm ²] [kg/cm ²]
A) lled soil, not artificially sompacted	0 - 1
B) Natural soil, apparently undisturbed	
1. sludge, peat, marshy earth	0
2. noncohesive, sufficiently firm soil: fine to medium sand course sand to gravel	1,5 2,0
3. cohesive soils: loamy soft stiff semi solid hard	0 0,4 1,0 2,0 4,0
4. rock with a minimum of fissures, in healthy, unweathered condition and favorably situated: in densely packed strata solid or column formation	15 30
C) Artificially compacted ground	
1. asphalt	5 - 15
2. concrete concrete groupe B I concrete groupe B II	50 - 250 350 - 550

If there is any doubt as to the load-bearing capacity of the ground at the operating site, the ground must be investigated; for example, with a dynamic sounding rod.

CAUTION: Only stable materials, such as wood planks of sufficient strength and size, may be used to make a foundation beneath the support pads. In order to achieve an even distribution of pressure above the foundation surface, the supports must be positioned in the middle of the foundation.

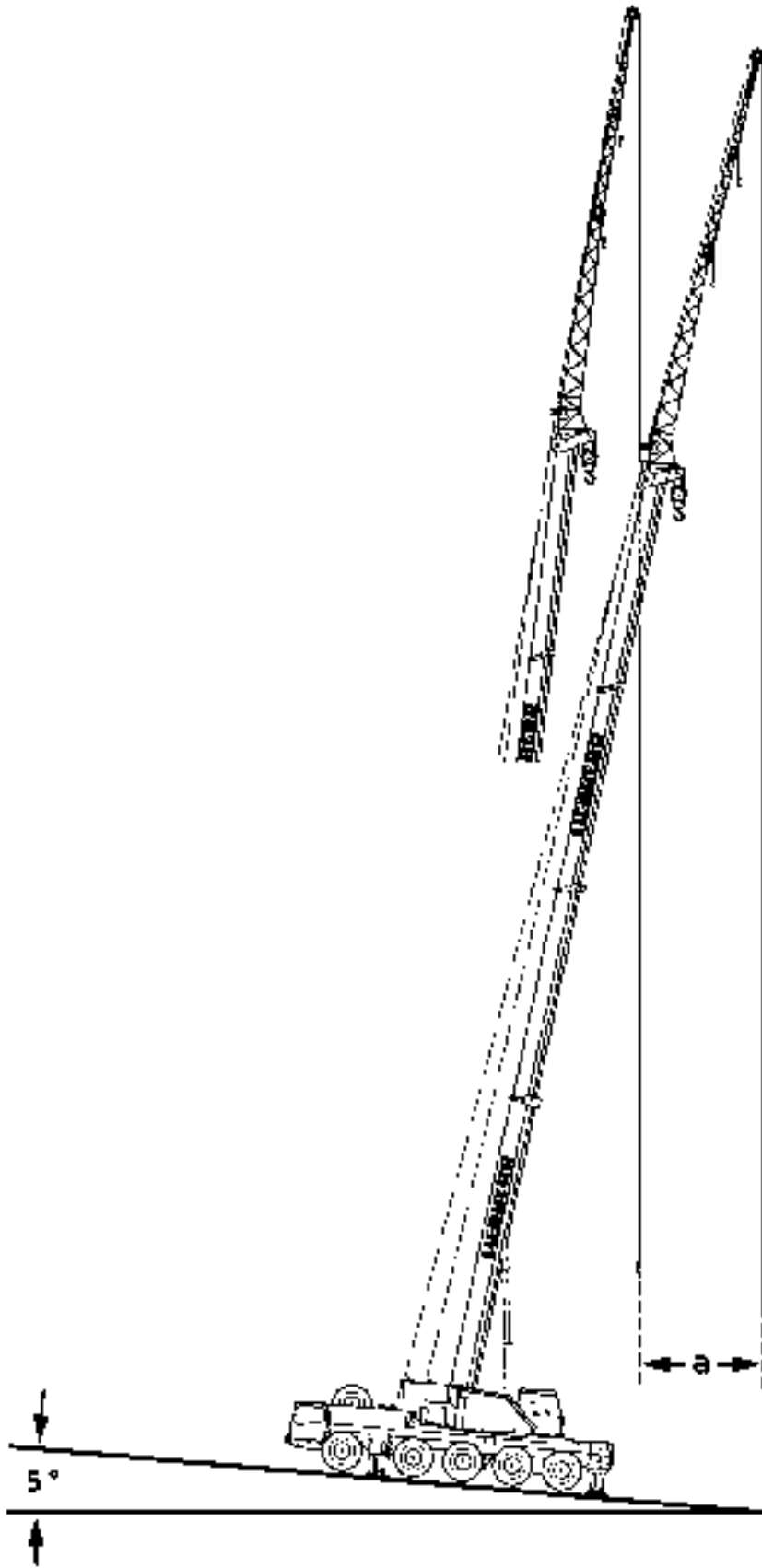

Support pads

Strict adherence to the support base in reference to load-capacities as given in the load-capacity table is absolutely essential to the safety of crane operations.

Equal distribution of pressure on the support pads of the sliding arms must be established so that the transmission of transverse force between the sliding arms is guaranteed.

The outriggers may only be used when the sliding arms are extended in these positions!

DANGER: Intermediate adjustments between the prescribed support widths may not be made as the transmission of transverse force is only possible above lateral support bases and, because of the absence of a support base in intermediate positions, an incorrect initiation of force is applied to the upper boom.
The sliding arms must be pinned securely to prevent any movement of the support jacks, which could cause a serious accident!
The pins must be fully inserted and the handle must point downward, otherwise it could cause a serious accident, causing the crane to topple over.

Always extend all 4 sliding arms and support jacks, including those on the side opposite the load. If only the sliding arms and support jacks on the load side are extended, the results could be dangerous as:

DANGER:

1. **The load hanging on the hook tensions the hoist cable and the telescopic boom and also the lattice fly jib if used and the guy cables) and also deforms them. If, in this situation, the load were to drop out of the lifting tackle cables, or if the lifting tackle cable or hoist cable were to break, the load on the boom would be suddenly lifted and the boom would jerk up violently. Therefore the crane may topple over.**
2. **Despite what has been assumed before commencing operations, it may prove necessary to slew the load to the opposite side. Therefore the crane may topple over.**
3. **When turning from longitudinal direction, the crane can tip over due to the momentum of the boom or counterweight.**

Aligning the crane

Besides the proper foundation beneath the supports, horizontal alignment of the crane is essential to operational safety.

DANGER: If the crane is set up unevenly and the boom is swung toward a downhill grade, the result is an extension of the boom radius, which in extreme cases can cause the crane to topple over.

Example: At a boom length of 50 m, uneven adjustment of the crane by only 5° will cause an boom radius of 10 m to be increased by a = 4 m.

Checking safety measures**Crane supported**

- Is axle suspension blocked?
- Is the load-bearing capacity of the ground sufficient?
- Are all 4 sliding arms and support jacks extended to the support base as given in the load-capacity tables?
- Are the sliding arms secured with bolts?
- Are the support pads secured?
- Is the crane horizontally aligned?
- Is there sufficiently safe distance from slopes and trenches?
- Have the axles been relieved of loads, i.e., is there no longer contact between the ground and the tires?
- Has it been established that the crane is not in the vicinity of electrical overhead wires?
- Has the operating site been selected so that the crane may operate within the smallest possible boom radius?
- Are there any obstacles in the area that will hinder necessary crane movements?

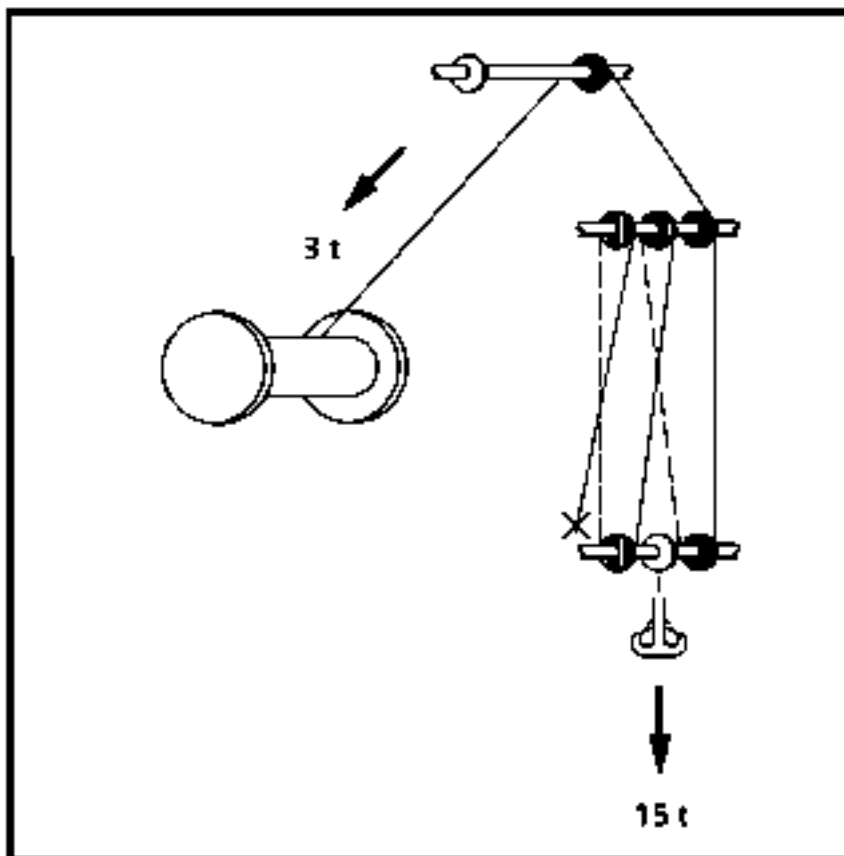
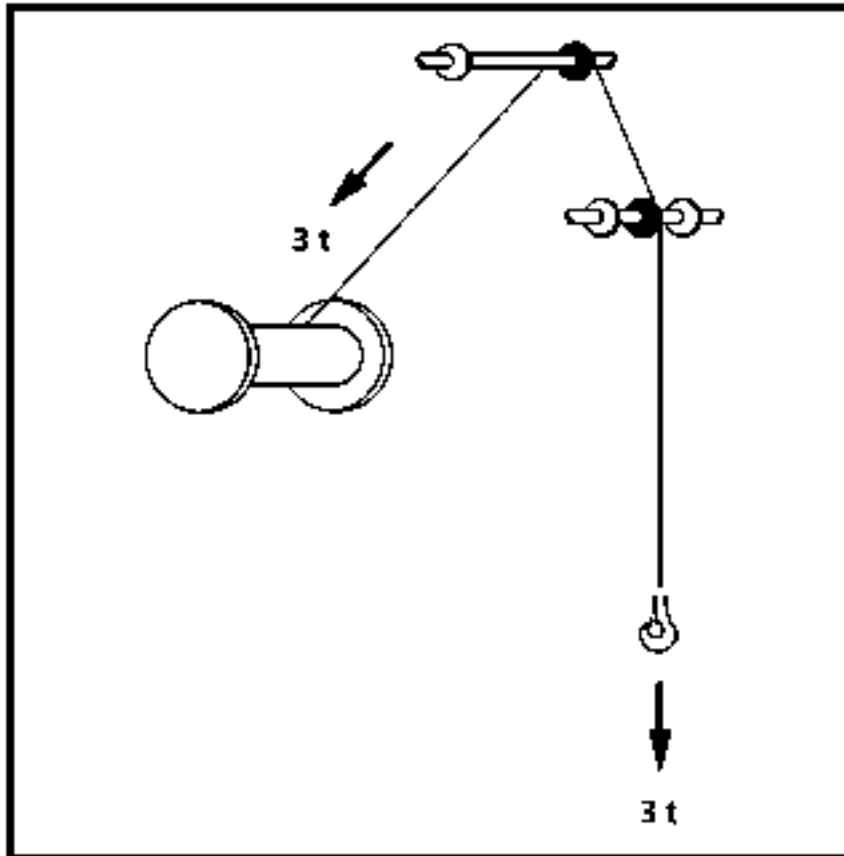

180002

Crane operation with a load

Before beginning any work, the crane operator must be convinced that the crane is in safe operating condition. The safety devices, such as load torque limiter, hoist limit switch, brakes, and so forth, must all be operational.

- The load torque limiter must be set to the current operating status of the crane.
- The load capacities as given in the load capacity tables must be adhered to. The crane must never be operated with a load exceeding the permissible load capacities.
- Before beginning any operations, the crane operator must know the weight and dimensions of the load.
- All hoisting and slinging tackle must meet the requirements of the work to be carried out.
- It must be ensured that the weights of the hoisting, slinging and staying tackle are taken from the load capacity table.

Example:

Highest permissible load capacity according to table	30.000 kg		<u>30.000 kg</u>
Weight of the hook block	370 kg	./.	370 kg
Weight of the slinging rope	40 kg	./.	40 kg
Actual useful load of the crane	Table value	=	<u>29.590 kg</u>
In this case, the load to be lifted may not exceed 29,590 kg .			

Ballast

The required ballast is dependent on the load to be lifted and necessary boom radius for operating with that load. Data in the corresponding load capacity table is decisive in selecting ballast.

D A N G E R : **If ballast is not mounted according to the load capacity table, there is danger of the crane toppling over.**

Hoisting gear, hoisting cable

The lifting capacity of the crane depends on the tensile force, or pull, of the hoisting cable and the number of possible hoist reeving cables. When working with a single cable, the crane can only lift as much as the hoisting gear pulls.

If the load to be lifted is greater than the pull of the hoisting gear, the hoisting cable must be reeved between the pulley head on the boom and the hook block as many times as necessary according to the principle of a block and pulley.

When reeving, ensure that the data given in the load capacity table book and operating instructions are observed and adhered to.

D A N G E R : **If the maximum tensile force is exceeded, there is the danger that the cable(s) may snap or that the hoisting gear and/or drive motor may be damaged.**

Crane operation

DANGER exists if:

1. The load torque limiter is not set to the actual equipment status of the crane, and as a result, cannot fulfil its function as a safety device.
2. The load torque limiter is defective or put out of operation.
3. The sliding arms of the hydraulic supports are not extended to the points specified in the load capacity table.
4. The support pads are not supported with stable base material sufficiently large for the soil conditions.
5. If the load is pulled at an angle. It is particularly dangerous when pulling to the side since the telescopic boom has a lower torque resistance to the side. **The load may not be pulled at an angle.**
6. An excessive load is attached to the hook during dismantling work, which then hangs freely on the crane when it is detached.
7. If loads which have become stuck are pulled free with the hook block. Even if the weight of the load which is stuck is no greater than the permissible lifting load, the crane may topple over backwards if the load is suddenly freed since the tension created in the boom can cause it to jerk back violently.
8. Work is carried out in strong winds. Refer to the data given in the load capacity table.
9. The crane is not aligned horizontally and the load is slewed toward the slope.
10. The hook load begins swinging because the crane operator has not properly controlled the movements.
11. The loads and radii contained in the load capacity tables are exceeded.
12. When working in the vicinity of power cables, these are not isolated by electricity engineers or if the hazardous area is not covered of fenced off. If it is not possible to take such measures, a sufficient safety clearance must be maintained:

Rated Voltage	Minimum distance	
	[m]	[ft]
up to 1 kV (1000 V)	1	3
above 1 kV up to 110 kV	3	9
above 110 kV up to 220 kV	4	13
above 220 kV up to 380 kV	5	16
if rated voltage is unknown	5	16

Note: If, despite all precautions having been taken, a flashover occurs, carry out the following procedure:

- Keep calm.
- Do not leave the crane cab.
- Warn those around the crane not to move and not to touch the crane.
- Move the crane away from the danger area.

DANGER: Not observing the above points can lead to (fatal) accidents and damage!

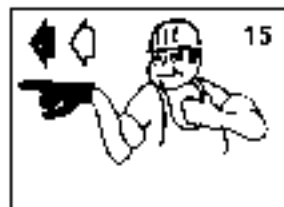
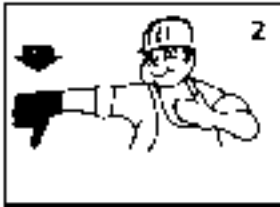

A suspended load is always a risk

When performing any movement, the crane operator must always keep his eye on the load, and when moving the crane without a load, he should observe the crane hook or the lifting tackle. If this is not possible, he must only operate the crane according to instructions given to him by a signaller. These instructions may be given in the form of hand signals or over a two-way radio. Whatever method is used, precautions must be taken to eliminate the risk of misunderstandings.

DANGER: Hand signals must first be discussed and agreed upon and then clearly given. Misunderstandings can lead to serious accidents.

The hand signals illustrated on the opposite page are given as recommendations for safe working.

When operating in foreign countries, always observe NATIONAL TRAFFIC REGULATIONS.

Explanation of hand signs

- 1 = Raise boom
- 2 = Lower boom
- 3 = Lift load slowly
- 4 = Lower load slowly
- 5 = Raise boom slowly
- 6 = Lower boom slowly
- 7 = Raise boom and hold load
- 8 = Lower boom and hold load
- 9 = Extend boom
- 10 = Retract boom
- 11 = Raise boom and lower load
- 12 = Lower boom and raise load
- 13 = Raise load
- 14 = Lower load
- 15 = Slew load this way
- 16 = Shut down all systems
- 17 = Stop!

Observing wind conditions

It is essential to adhere to the information given in the load capacity tables regarding the maximum permissible wind speed.

Crane operations must be stopped and the boom lowered as soon as the maximum wind speed is exceeded.

Wind Force		Wind Speed		Effects of Wind in the inland
Beaufort degree	Description	[m/s]	[km/h]	
0	Calm	0 - 0,2	1	No wind, smoke rises straight up
1	Slight air (draft)	0,3 - 1,5	1 - 5	Wind direction is shown only by observing the trail of smoke, not by the wind sock
2	Light breeze	1,6 - 3,3	6 - 11	Wind can be felt on the face, the leaves rustle, wind sock moves slightly
3	Gentle breeze	3,4 - 5,4	12 - 19	Leaves and thin twigs move Wind extends a small breeze flag
4	Moderate breeze	5,5 - 7,9	20 - 28	Swirls up dust and loose paper, moves twigs and thin branches
5	Fresh breeze	8 - 10,7	29 - 38	Small deciduous trees begin to sway, foam forms at sea
6	Strong wind	10,8 - 13,8	39 - 49	Thicker branches move Telephone lines begin to whistle, umbrellas are difficult to use
7	Stiff wind	13,9 - 17,1	50 - 61	Entire trees swaying; difficult to walk into wind
8	Gale force wind	17,2 - 20,7	62 - 74	Breaks twigs off trees, walking becomes difficult
9	Gale	20,8 - 24,4	75 - 88	Minor damage to property (chimney tops and roofing tile are blown off)
10	Severe gale	24,5 - 28,4	89 - 102	Trees are uprooted, significant damage to property
11	Violent storm	28,5 - 32,6	103 - 117	Extensive, widespread storm damage
12	Hurricane	32,7 - 36,9	118 - 133	Major destruction

Chapter 3

Operation of the Chassis

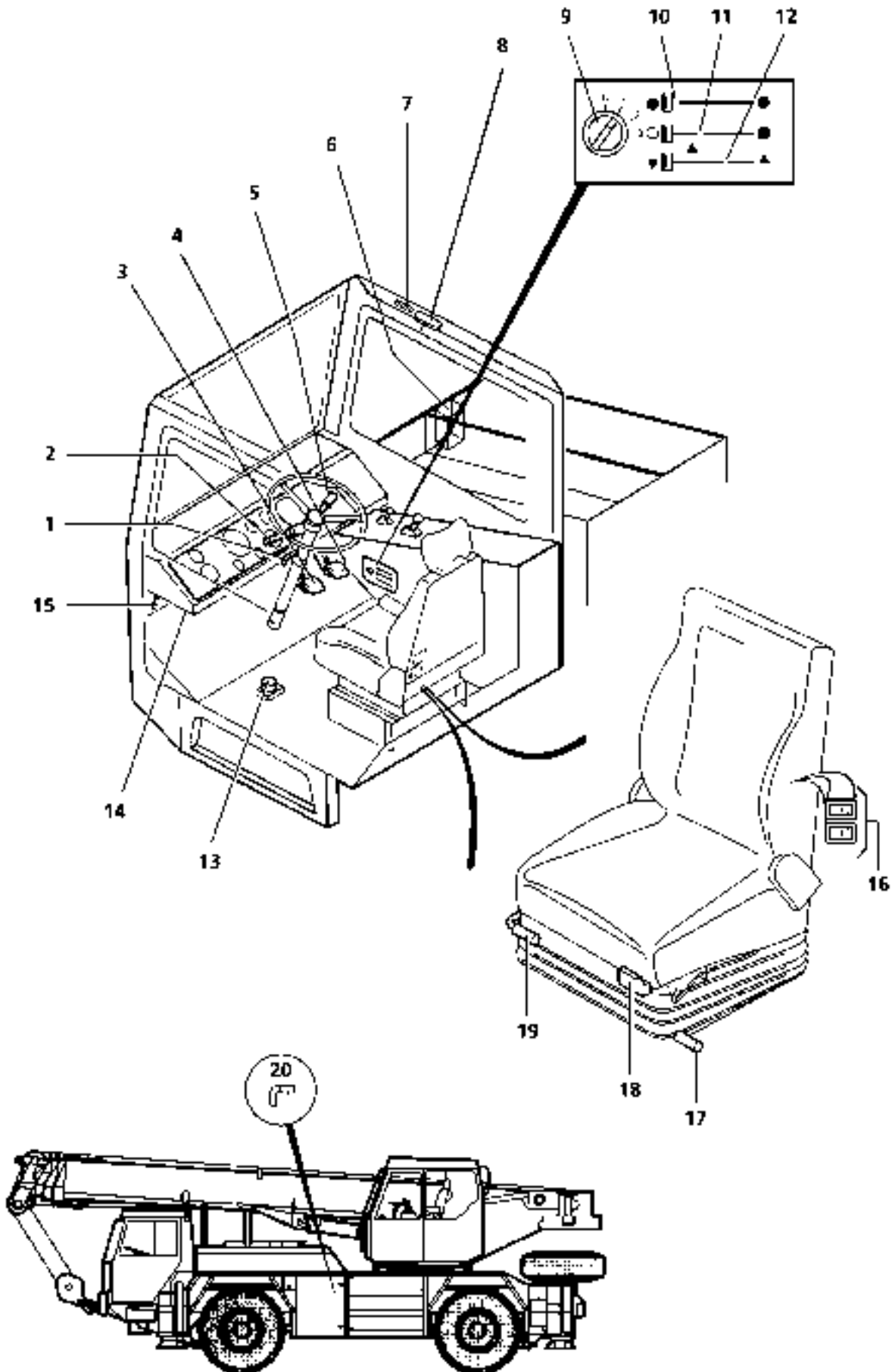

Pos.:

1	Steering wheel angle adjustment	
2	Steering column switch for	- Operating blinkers - Operating windshield wipers - Intermittent - Operating windshield washer - Low/high beam - Operating signal horn - Operating headlight flasher
3	Foot pedal	- Service brake
4	Foot pedal	- Motor regulation
5	* Steering column switch	- Eddy current brake
6	Container	- Windshield washer fluid
7	Acoustical warning	- Engine overspeeding
8	Interior light with switch	
9	Rotary switch	- ventilator, 3 level
10	Sliding control	- Temperature
11	Sliding control	- Recirculated air / fresh air operation, air quantity
12	Sliding control	- Airstream upwards / downwards
13	Foot button	- Motor brake (retarder)
14	Fuse box	
15	Switch	- Chassis / superstructure operation
16	Button	- Lower back support in upper and lower region of the seat back.
17	Lever	- Latch release for horizontal seat adjustment
18	Lever	- Seat back angle adjustment
19	Lever	- Seat angle adjustment
20	Main battery switch	

* Optional

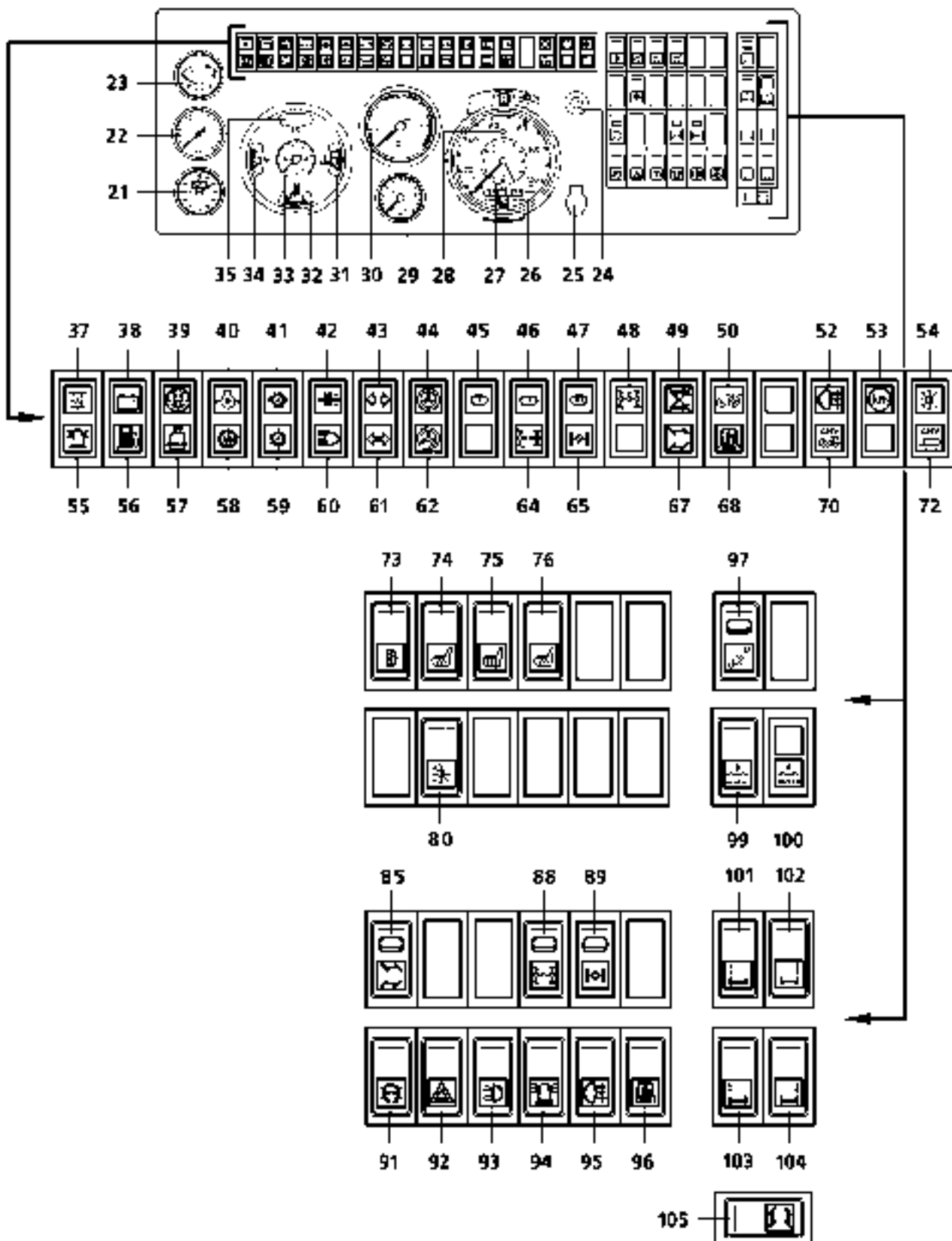

Pos.:

21	Operational hours counter	
22	Display	- Torque converter oil pressure
23	Display	- Torque converter oil temperature
24	Key switch	- Ignition, start
25	Socket	- 24 V DC
26	Tachograph with speedometer, odometer and clock	
27	* Warning light	- Trip log problem (pens do not register or diagram disk has not been inserted)
28	* Warning light	- Certain, factory adjusted max. speed is being exceeded
29	Duplex air pressure gauge for reserve and braking pressure - brake circuit II	
30	Tachometer	- Diesel engine RPM
31	Display	- Diesel engine coolant temperature
32	Display	- Fuel tank level
33	Duplex air pressure gauge for reserve and braking pressure - brake circuit I	
34	Display	- Diesel engine oil pressure
35	Indicator lamp	- Hand brake engaged
36	Reserved	
37	Indicator lamp	- Preheat Diesel engine
38	Warning light	- Alternator
39	Warning light	- Air filter contaminated
40	Warning light	- Engine oil pressure too low
41	Warning light	- lights when oil pressure in torque converter / on-load shift gearbox oil circulation too low
42	Indicator light	- lights if the by-pass coupling converter (lock-up) is open
43	Indicator light	- Travel direction - vehicle
44	Warning light	- Steering circuit I
45	Warning light	- Air pressure supply - Brake circuit I
46	Warning light	- Air pressure supply - Brake circuit II
47	Warning light	- Air pressure supply - Brake circuit III
48	Indicator light	- Hydraulic pump for crane operation switched on
49	Warning light	- Rear axle steering locking / release intermediate position
50	* Indicator light	- Eddy current brake switched on
51	Reserved	
52	* Indicator light	- Rear fog light
53	* Warning light	- Speed limiter
54	* Indicator light	- Air conditioner
55	Indicator light	- Beacon
56	Warning light	- Fuel level is too low
57	Warning light	- Coolant level - travel engine is too low
58	Warning light	- Coolant temperature is too high
59	Warning light	- lights when oil temperature in torque converter / on-load shift gearbox oil circulation too high
60	Indicator light	- Headlight - High beam / low beam
61	Indicator light	- Direction of travel display - trailer
62	Warning light	- Steering circuit II
63	Reserved	
52	Indicator light	- "All-wheel drive" (first axle drive switched on)
55	Indicator light	- Driven axles transverse differential lock on

* Optional

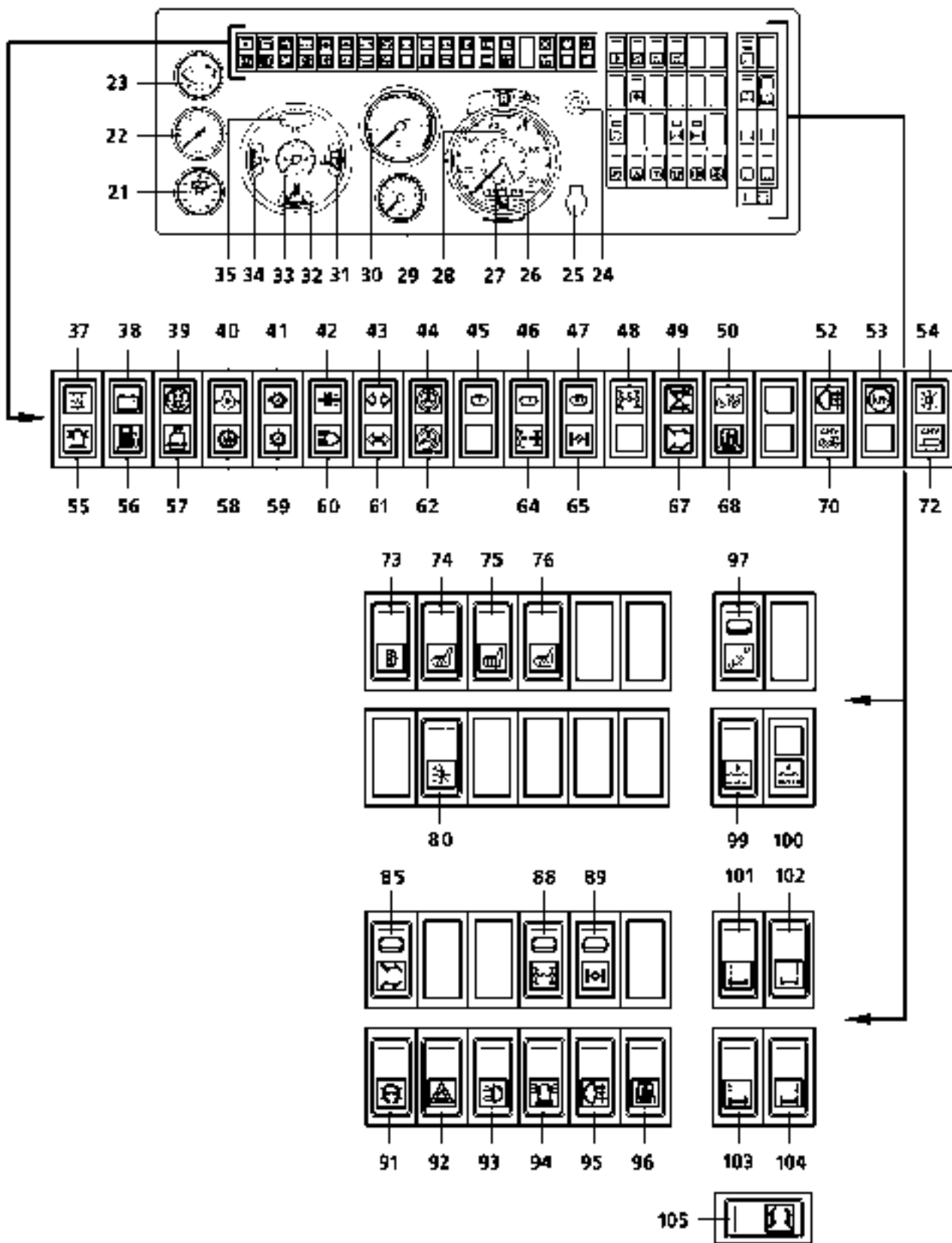

Pos.:

66		Reserved	
67		Indicator light	- Locking / release of rear axle steering
68	*	Indicator light	- Driver's cabin auxiliary heater
69		Reserved	
70		Warning light	- ABV, Automatic brake blocking prevention on the vehicle . These warning lights must turn off at a travel speed of more than 10 km/h . If they do not turn off, then there is a problem with the electronic ABV control for the vehicle.
71		Reserved	
72		Warning light	- ABV Automatic brake blocking prevention on the trailer When a trailer is attached, this warning lights must turn off at a travel speed of more than 10 km/h . If it does not turn off, then there is a problem with the electronic ABV control for the trailer .
73	*	Switch	- Outside mirror heater
74	*	Switch	- Seat heater, left
75	*	Switch	- Seat heater, center
76	*	Switch	- Seat heater, right
77		Reserved	
78		Reserved	
79		Reserved	
80	*	Switch	- Air conditioner
81		Reserved	
82		Reserved	
83		Reserved	
84		Reserved	
85		Switch	- Release / lock of rear axle steering
86		Reserved	
87		Reserved	
88		Switch	- "All wheel drive ", Engage drive for 1st axle
89		Switch	- Engage transverse differential lock for driven axles
90		Reserved	
91		Button	- Engine Stop button
92		Switch	- Hazard warning blinker with indicator light
93		Light switch	- (2stage) for parking lights, head lights and instrument lighting
94		Switch	- Beacon with indicator light
95	*	Switch	- Rear fog light
96	*	Switch	- Auxiliary heater for cab and preheat system for Diesel engine *
97		Switch	- Axle suspension blocked / suspended
98		Reserved	
99		Button	- "NIVEAU", for automatic height adjustment of axle suspension for on road travel
100		Indicator light	- "NIVEAU", lights up if axle suspension for on road travel is turned on (as long as button (99) is depressed)
101		Button	- Vehicle, left front Raise / lower
102		Button	- Vehicle, right front Raise / lower
103		Button	- Vehicle, left rear Raise / lower
104		Button	- Vehicle, right rear Raise / lower
105		Button	- Engage rear axle steering

* Optional

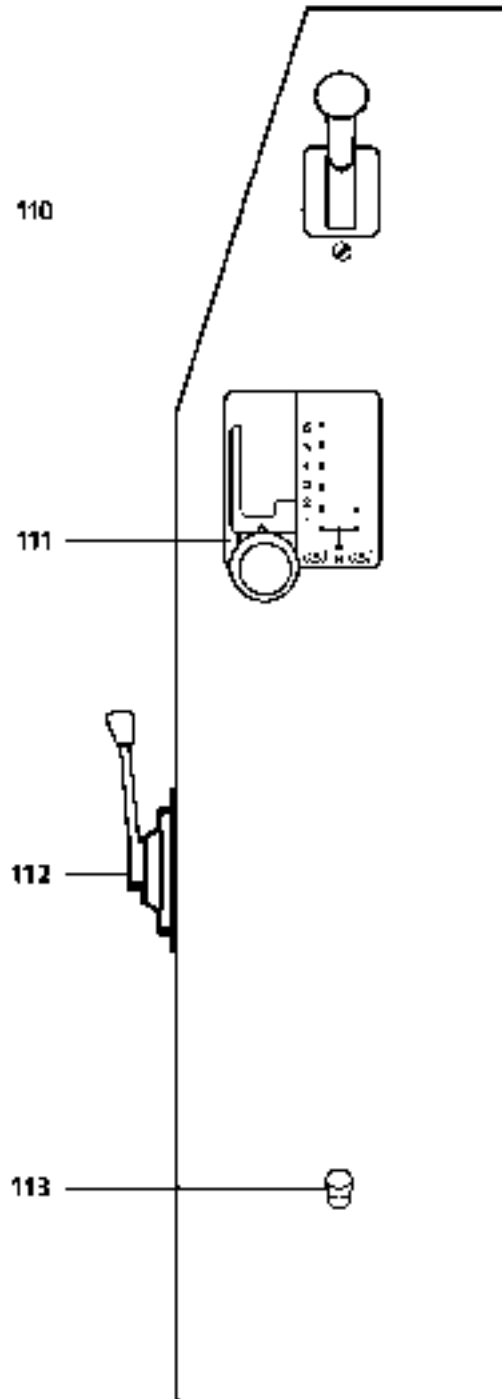

Pos.:

106	Reserved	
107	Reserved	
108	Reserved	
109	Reserved	
110	Manual lever	- Parking brake
111	Gear selector switch	
112	Manual lever	- Engine regulation (throttle control)
113	* Button	- emergency relief valve for parking brake

* Optional

Prechecks before starting up the vehicle

Before starting up the vehicle, the following prechecks must be carried out:

Note: For a more complete description of the following precheck procedures, see Chap. 7.04, **NOTES ON MAINTENANCE**.

Precheck of oil level and filter

- oil level in the driving engine
- oil level in the automatic transmission
- oil level in the hydraulic tank for steering, support and axle suspension
- filter on the hydraulic tank for steering

Precheck of fuel level

Check the fuel supply on the fuel gauge in the driver's cab.

Precheck of coolant

The coolant must be filled to the rim on the filling nozzle.

DANGER: NEVER check the coolant level if the engine is still warm. To check, the engine must be cold, otherwise there is the danger of serious skin burns!

Precheck of tires

Check the condition of the tires, including the spare.

DANGER: There is an increased danger of accidents if the tires are damaged, the profiles are not deep enough, or the air pressure in individual tires varies!

Check the ballast fixture

Inspect the locking catches of the ballast slabs and locking pots for damage.

DANGER: If locking catches are broken off, or deformation of the support frame has occurred, the secure seating of the ballast slabs is no longer ensured. As a result the ballast slabs can fall off.

If damage has occurred the locking device or ballast slab must be replaced.

If a bracket is bent, the stacker bracket must be straightened.

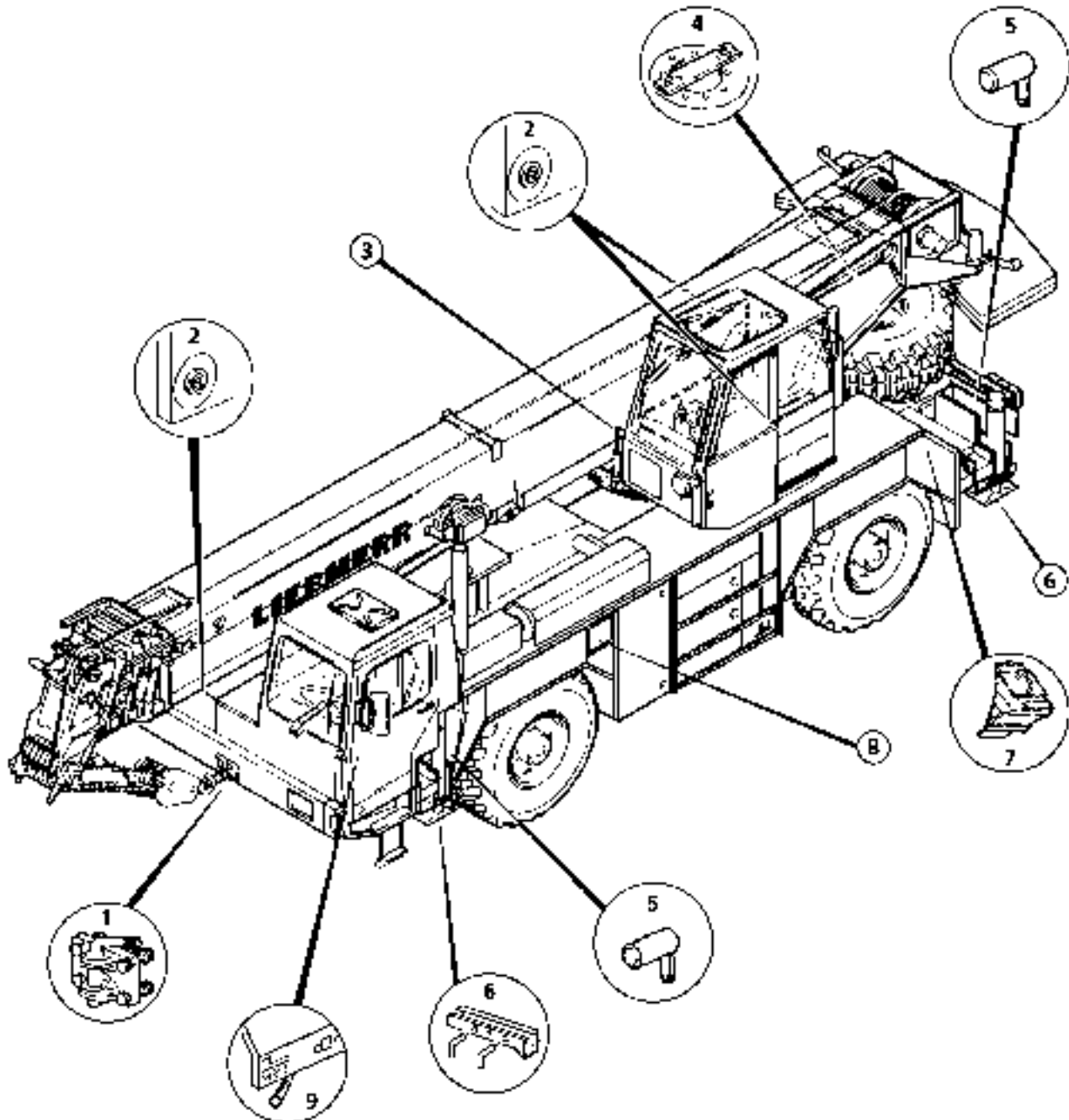

General transport condition

For travel purposes, all loose parts must be securely lashed to the crane.

- The axle suspension system must be switched to "Suspended". (See Chapter 3.03.)
- The rear axle steering must be locked into "Straight position".
- The hydraulic pump for the support and rear axle steering hydraulics must be switched off.
- The change-over lever (9) must be in the "chassis" position.
- The crane superstructure must be aligned in the direction of travel and be positively mechanically secured against turning with lynch pins (3).
- The telescopic boom must be completely retracted and lowered in the boom receiver and the slewing gear brake must be engaged. In addition, the telescopic boom must be locked to prevent it from running free. The hook block must be hung in the eye of the front tow coupling provided for this purpose and pulled tight.
- Make sure that the engine cowling and all cabinet doors on the crane superstructure (2) are closed and locked.
- The windows and doors of the crane operator's cab must be closed.
- The four sliding arms of the hydraulic supports must be individually secured with pins (5) to prevent unintentional extension. Lever position of the pins must be down.
- The four support pads must be stowed and secured in their receivers. The receivers must be pinned (6).
- The wheel chocks (7) must always be carried and secured in their holders to prevent them from falling out.
- Switching cabinet (8) must always be locked.
- Check the steps beneath the driver's cab door for damage.
- Check all pins and spring keepers to make sure they are securely attached on:
 - Spare tire (4)
 - Support pad receivers (6)
 - Support locking pins (5)
 - Pin in the hoisting cable winch coupling (1)
- Check for completeness and secure for transport all locking pins used in crane operations.
- Ensure that all ballast is secured and locked.

D A N G E R : **All spring keepers and locking pins are to be so secured that they cannot come loose by themselves during transport and in doing so cause an accident or damage. If the safety, locking, and securing measures and controls found in the chapter "General transport condition" are not adhered to, there is an increased risk of accidents!**

Note: When driving on public roads, in order to maintain the maximum axle pressure of 12 t, the total ballast, the hook block and the double folding fly jib must be transported separately as described in Chap. 3.04, **DRIVING ON PUBLIC ROADS**.

A hook block (one or three pulley) may only be transported if

- it is, at a maximum, quadruple reeved,
- it has been marked by the manufacturer on the identification plate "E" for "RENDERED SAFE",
- it is hung in the eye of the tow coupling (1) provided for this purpose and pulled tight.

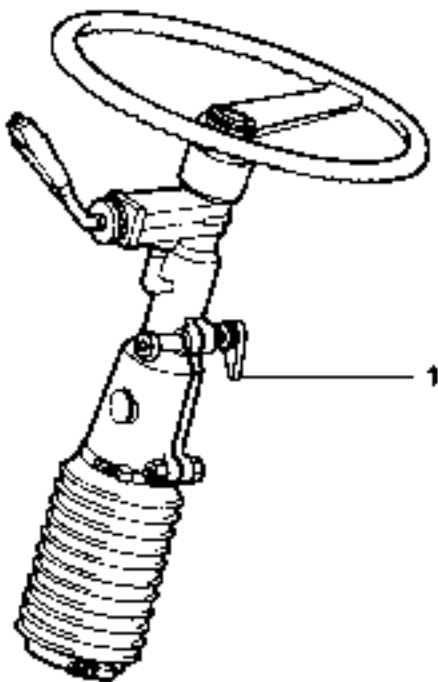
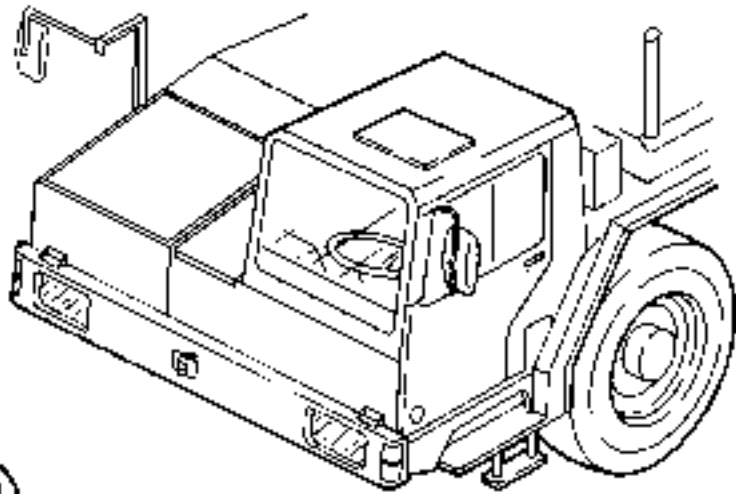
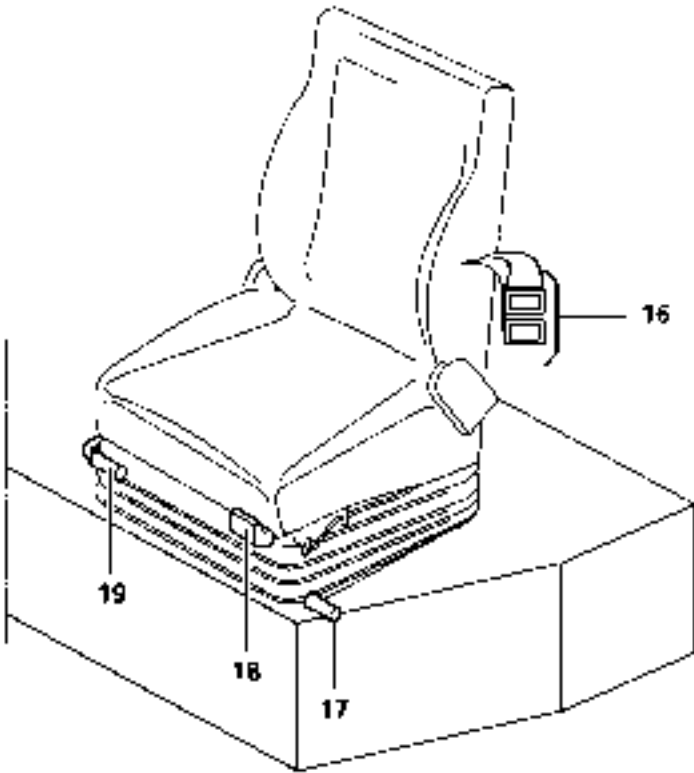

Adjusting the driver's seat

The hydraulically suspended driver's seat can be adjusted to any size required:

- Lower back support (16)
- Horizontal seat adjustment (17)
- Angle of the seat back (18)
- Angle of the seat (19)

Adjustment for suspension hardness is carried out automatically.

Adjusting the mirrors

The outside mirrors which must be cleaned and adjusted to the driver's field of vision before the journey starts.

Adjusting the steering wheel

By releasing the steering wheel adjustment lever (1), the height and angle of the steering wheel can be adapted to the requirements of the driver.

DANGER: **The steering wheel, driver's seat and the mirrors must not be adjusted while driving. Always retighten the steering wheel height adjustment lever and angle adjustment lever.**

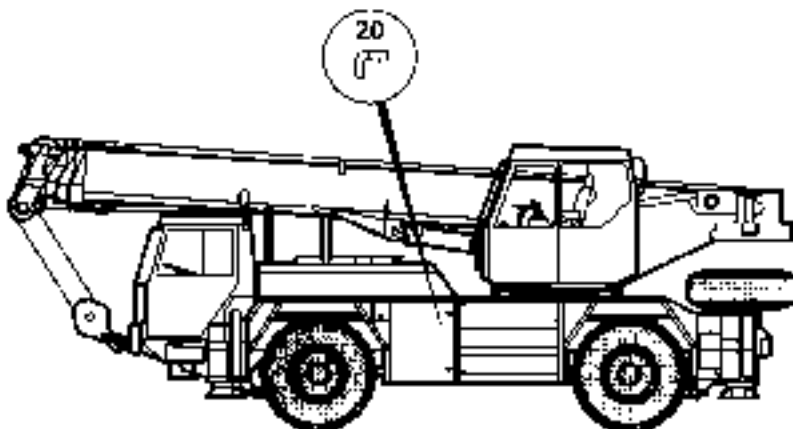
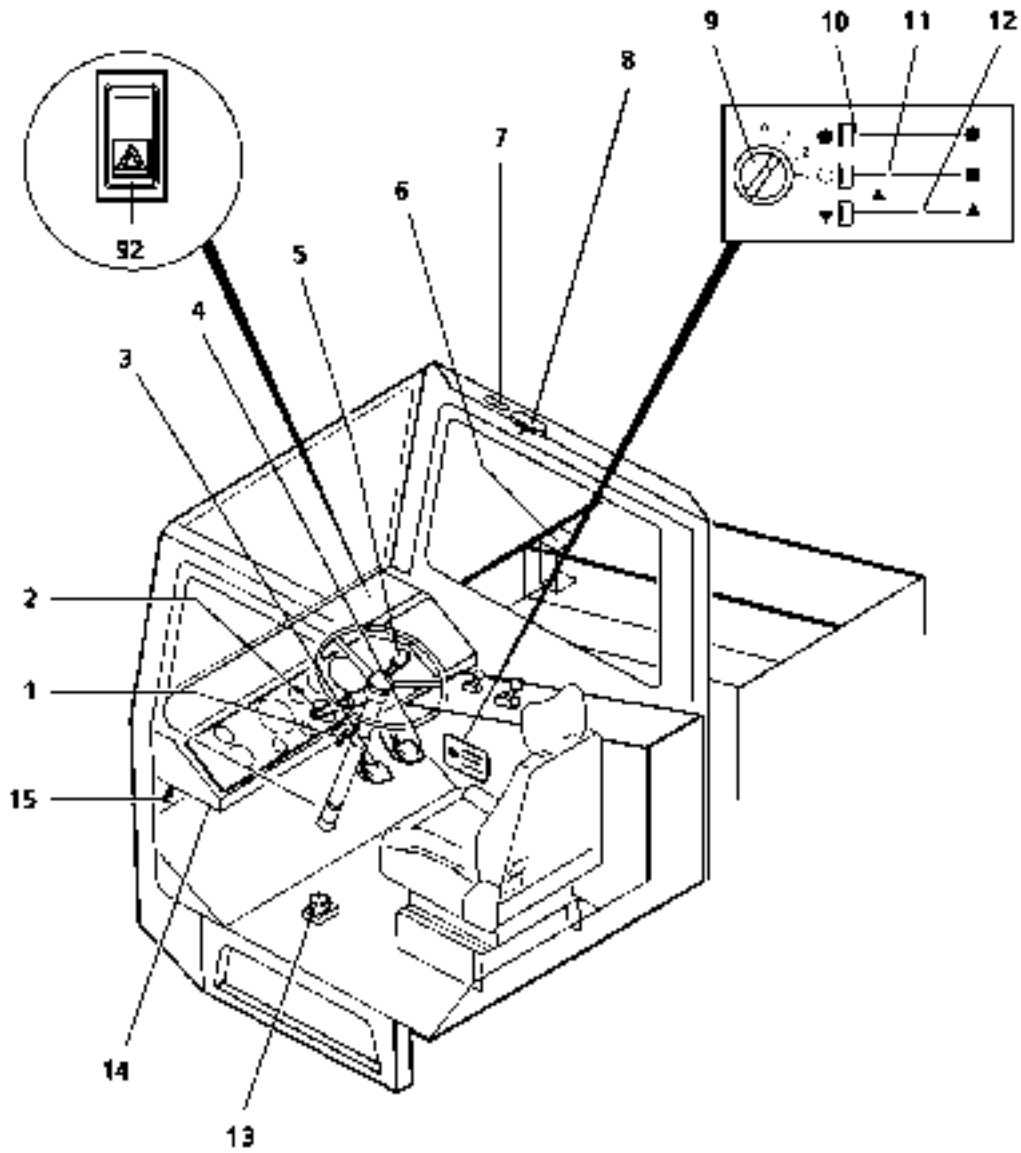

Checking the warning flashers, blower, windshield wipers, and horn

Note: This check can be carried out when the battery master switch (20) is switched on.

Before starting, check:

- a) **Before** the ignition is switched on
 - Switch-indicator lamp / warning flashers (92)
- b) **After** the ignition is switched on
(ignition key in the key-operated switch, turned to position "1")
 - Rotary switch (9) for blower-heating, ventilation (air-conditioning system)
 - Windshield wipers (2)
 - Windshield wiper system (6)
 - Horn (2)

DANGER: If the warning flashers, as well as any other functions are not operational, they must be repaired before starting up. Otherwise, there is an increased risk of accidents!

Checking the fuses

Remove the fuse box cover (14) and check the fuses. If any fuses are defective, they must be replaced.

CAUTION: Use only fuses of the same amperage. Not adhering to the same amperage can cause damage to the electrical system.

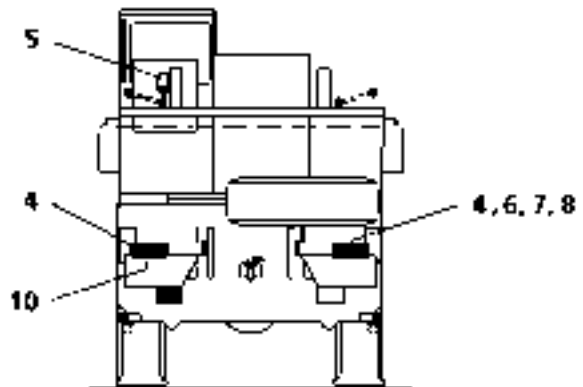
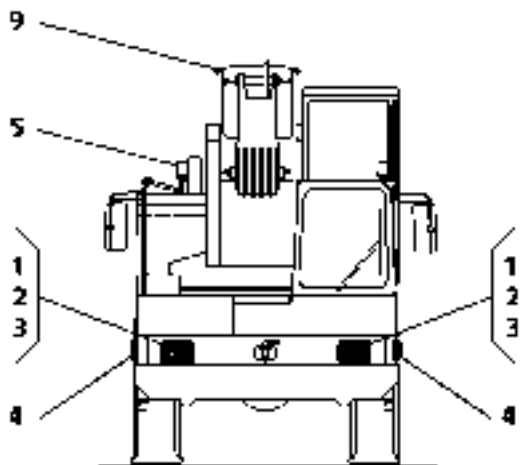
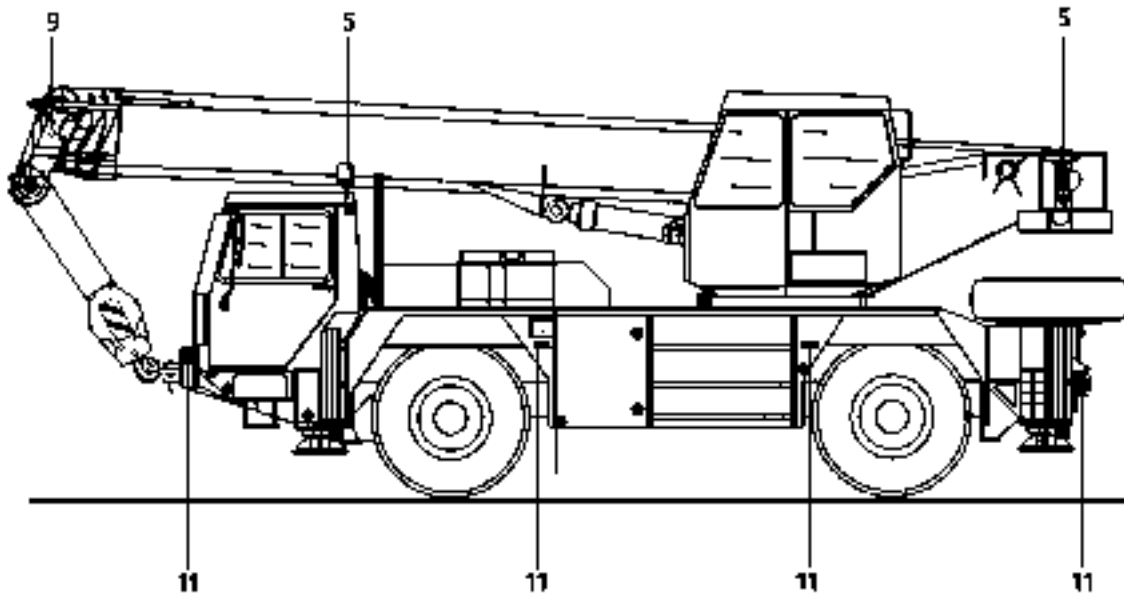

Checking the lights

Note: Controlling the lights can only be carried out if the main battery switch and the ignition are switched on.

All lights must be checked before starting up the vehicle:

- Parking lights front and rear (1)
- High beam/dim headlights (2 / 3)
- Blinkers (4)
- Rotating beacon identification lights (5)
- Brake lights (6)
- Reverse spotlight (7)
- Rear fog light (8)
- Boom head light (9)
- License plate illumination (10)
- Side marker lights
- Fog lights
- Working spotlights on the boom
- Display and control panel illumination

DANGER: Missing or defective lights increase the risk of accidents. Any defective lights must be repaired or changed before starting up the vehicle.

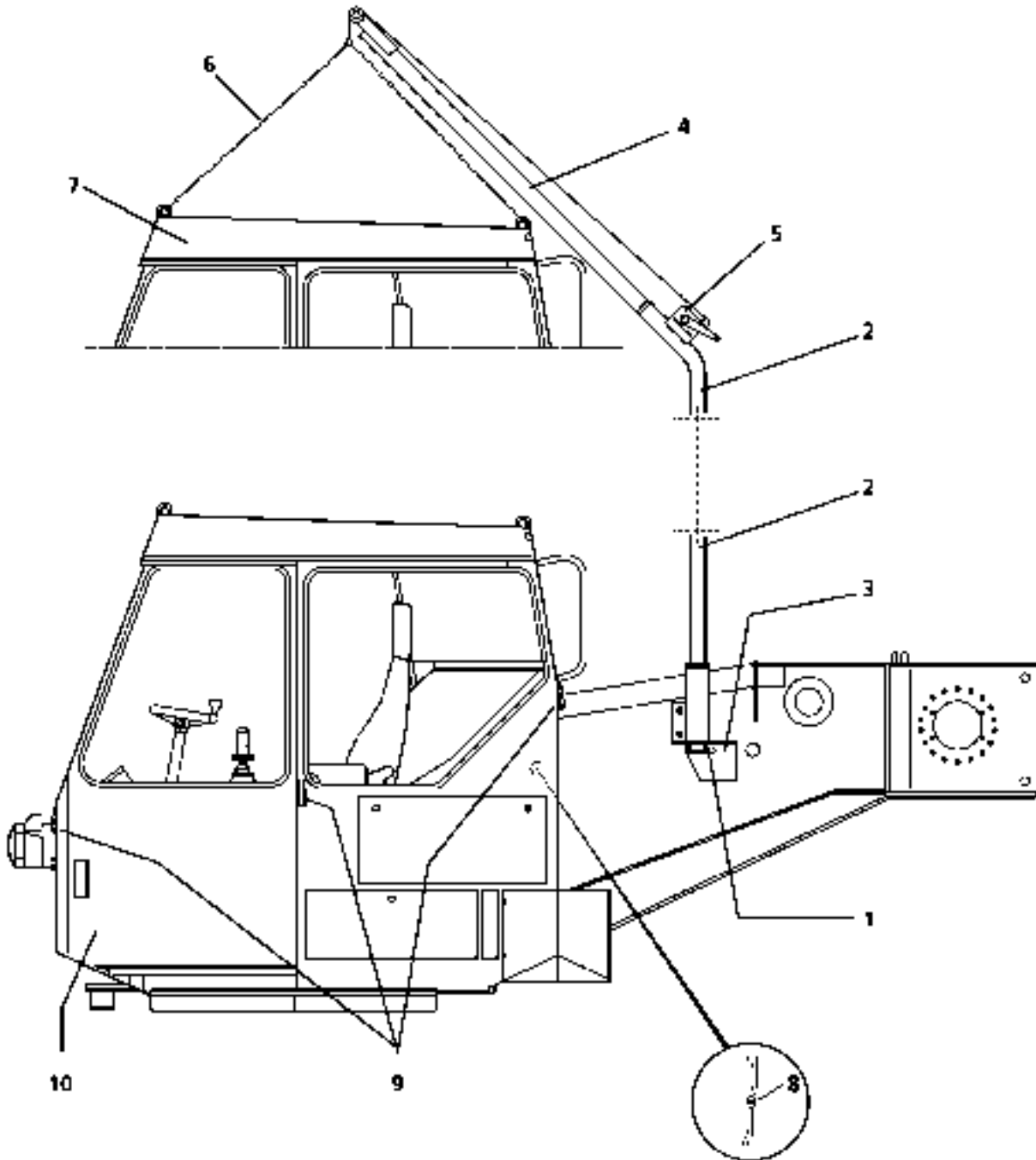

Divided cab *

To reduce the overall height for travel, the upper part of the crane operator's cab can be removed.

To remove

- Remove pin (1) from the removal device (2), move the removal device (2) from the transport position to the working position of retainer (3) and secure it in this position with pin (1).
- Remove the extension pipe (4) from its retainer (on the side of the boom) and attach it to the removal device (2).
- Route the rope from the winch (5) over the roller on the extension pipe (4), attach the hook chain (6) (quadruple) to this rope and to the 4 eyehooks on the top of the crane cab (7).
- Unplug electrical connection (8) between the upper and lower part of the crane.

Note: The cab doors must now be closed.

- Loosen all tension locks (9) and slightly lift the upper part of the cab with the winch.
- Open the door (10) about 5° towards the outside, so it can be pushed all the way towards the rear along the side wall without having to remove the lock and then removed from the guide rail.
- Remove the door (10) and set it aside.
- Lift off the upper part of the crane (7) fully and then set it aside also.

To install

- Lift the upper part of the crane cab with the winch and set it on the lower part of the crane cab.
- Insert the door in the guide rail (lean the door out about 5°) and push it forward.
- Lightly lift the upper part of the crane cab and set the door vertically.
- Bring the upper part of the crane cab to its final position, and lock down all tension locks.
- Reestablish the electrical plug connection (8) between the upper and lower part of the crane cab.
- Pull the rope from the extension pipe and roll it up on the winch.
- Remove the extension pipe from the removal device and affix it to the side on the boom.
- Remove the pin on the removal device, move the removal device from working position to transport position and secure it with the pin .

* Optional

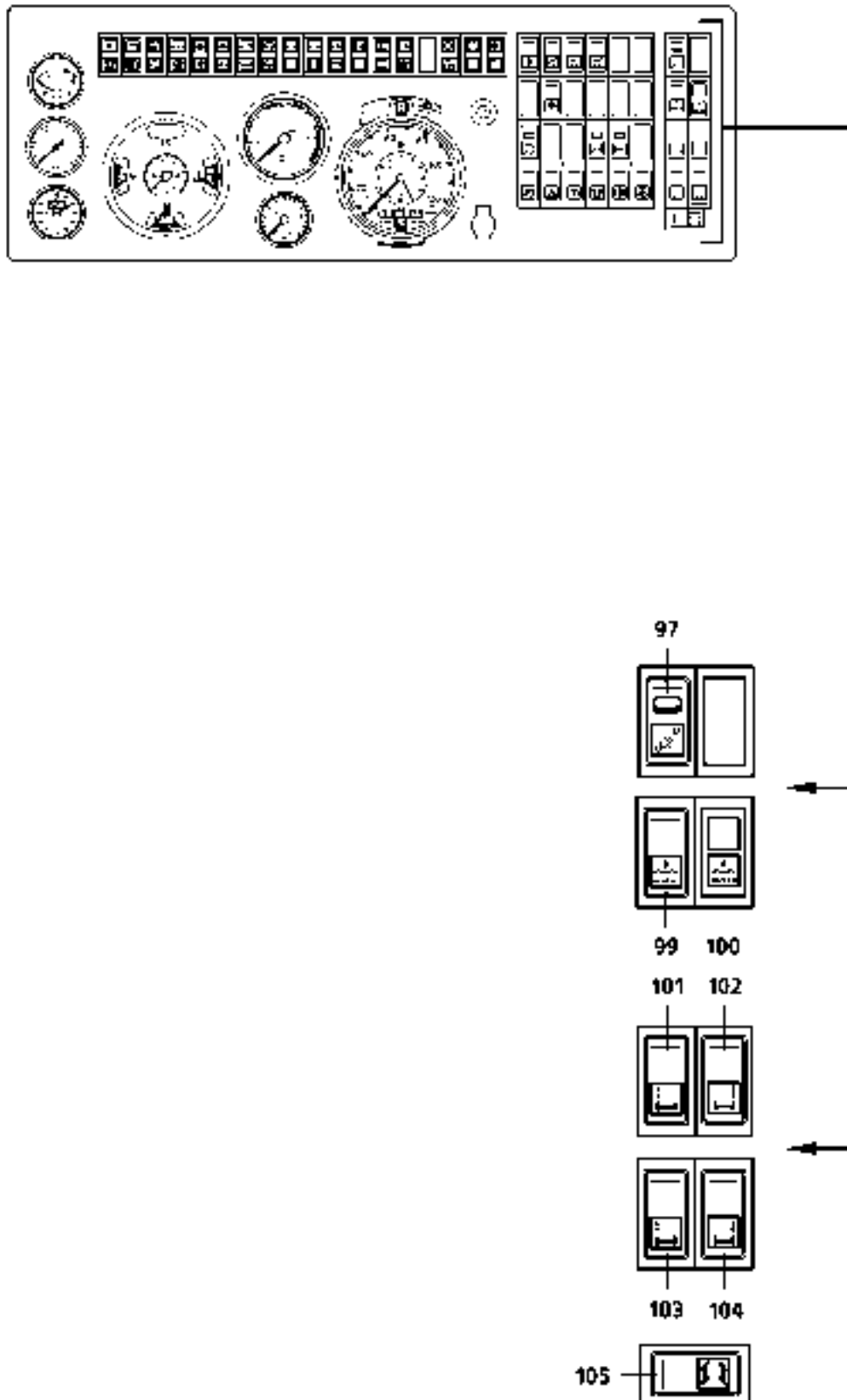

Description

All axles are hydropneumatically suspended with automatic levelling.

Each axle is connected to the frame via 2 hydraulic jacks acting as suspension and levelling units.

All suspension lacks are hung separately on reservoirs and blocking valves.

In addition, the entire vehicle can be raised or lowered via the hydropneumatic system, in order, for example, to reduce the crane's clearance height, or to improve its fording ability.

In addition, the forward left and right sides and the rear left and right sides of the vehicle can be raised or lowered separately.

Controls and instruments

in the driver's cab on the dashboard.

Item:

97	Switch	- Axle suspension blocked / suspended
99	Button	- Automatic levelling control, if this button is pressed, the crane is adjusted to the proper height for street travel via the hydraulic jacks.
100	Indicator lamp	- level adjusted; this lamp will remain on as long as button (99) is kept depressed.
101	Button	- manual axle pressure control, front axle, left
102	Button	- manual axle pressure control, front axle, right
103	Button	- manual axle pressure control, rear axle, left
104	Button	- manual axle pressure control, rear axle, right

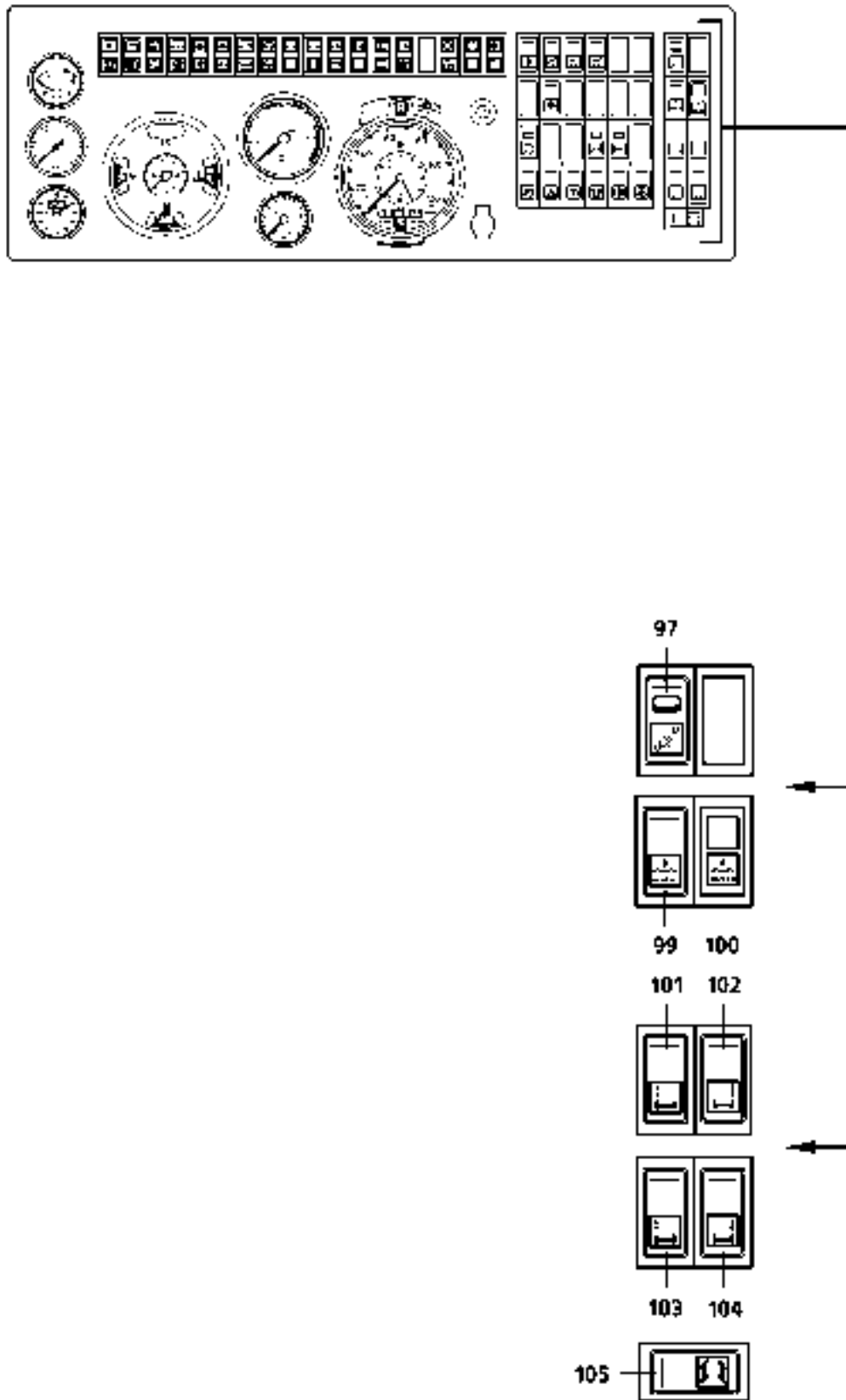

182907

Axle suspension "SUSPENDED"

Switch (97) must be switched off; in this position, all axles are suspended.

For transport journeys on public roads, highways and off-road.

In this switch position, the level of the crane can be either automatically or manually adjusted.

Automatic level control

Levelling control is carried out by pushing button (99) LEVEL until the indicator lamp (100) comes on.

The crane is automatically brought into level position by means of the levelling switch, found on the suspensions jacks.

Manual level control

By using the buttons (101, 102, 103, 104), the level can be adjusted by filling or discharging the hydropneumatic system, as follows:

- (101) - manual axle pressure control, front axle, left
- (102) - manual axle pressure control, front axle, right
- (103) - manual axle pressure control, rear axle, left
- (104) - manual axle pressure control, rear axle, right

Raise vehicle: Press button (101, 102, 103, 104) to the "rear"

Lower vehicle: Press button (101, 102, 103, 104) "forwards"

CAUTION: When driving on uneven surfaces (for example, off-road), the vehicle must never be completely raised or completely lowered.
The boom must be pointing in the crane's longitudinal axis forward and be supported and resting in the middle rest.

DANGER: Whenever operating the Axle suspension/locking system, there must be no persons within the danger area of the crane.

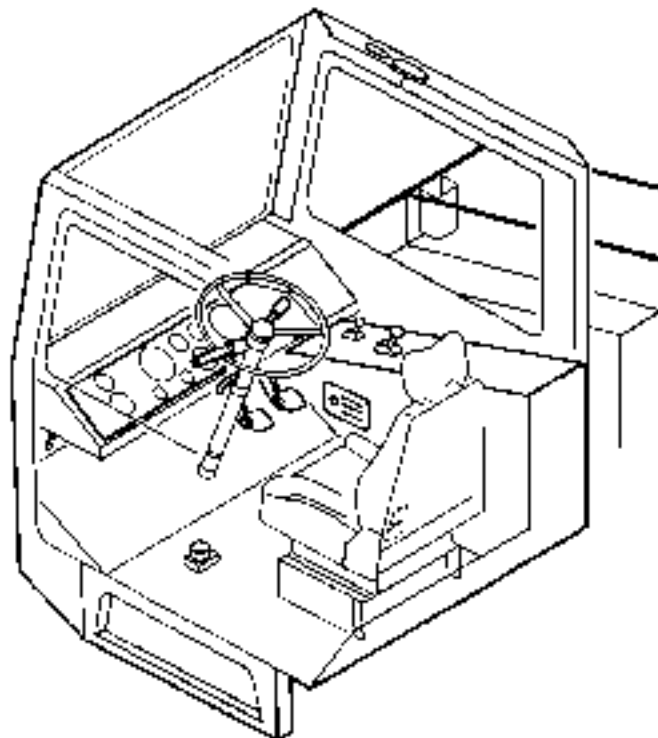
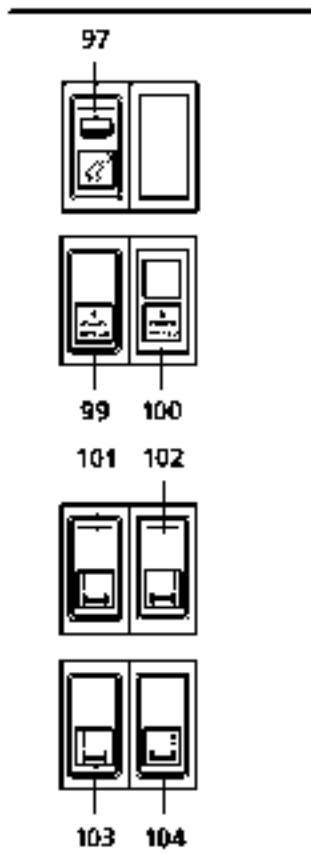
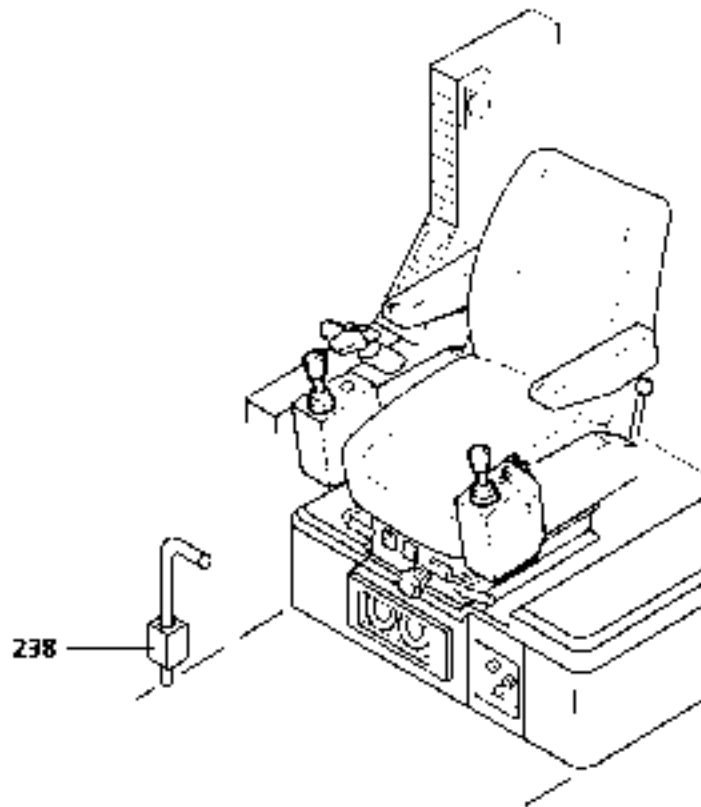
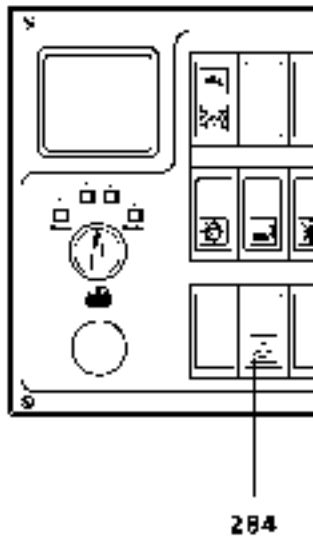

Axle suspension "LOCKED"

Unlock switch (97) and press on the symbol.

Lock switch.

Hydropneumatic suspension of all axles locked.

The axles must be locked :

1. **before supporting the crane with outriggers.**
2. **for driving the crane with a load.**

1.1 Supporting the crane

Before supporting the crane, axle suspension must be "LOCKED" by turning switch (97) on.

When extending the support jacks, the axles are raised until the wheels are no longer touching the ground

CAUTION: If this point is not observed, the axles could be damaged because the vehicle frame will bend during crane operation.

When lowering the supported crane onto the wheels, the support jacks must be retracted far enough until the wheels touch the ground again. Move switch (97) to "SUSPENDED".

CAUTION: The switch (97) for axle locking may only be switched off once the tires are in contact with the ground. If this is not done, axle suspension will be damaged due to sudden release of the axle blocking system.

2.1 For the working range "free-standing on wheels" and "driving the crane with a load"

This position is needed for working "Freestanding on tires" and "Driving the crane with a load" on a level surface of adequate load bearing capacity, as noted on the load capacity chart .

**CAUTION: Driving the crane with a load is only allowed "TO THE REAR", on a level, solid surface!
Maximum permissible deviation ± 0.15 m over a length of 10 m.
For this operation, the slewing platform must be locked to the chassis with pin (238); indicator lamp (284) must be on.**

* Optional

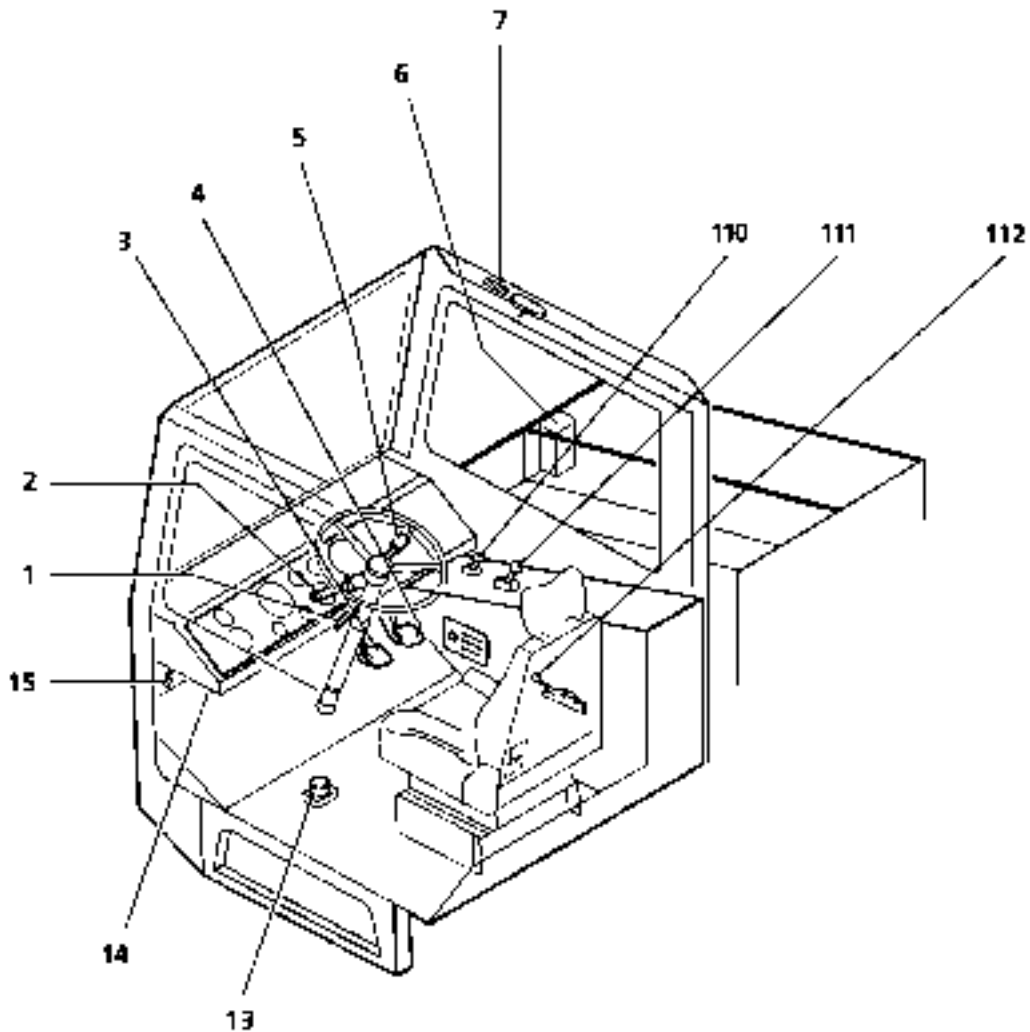
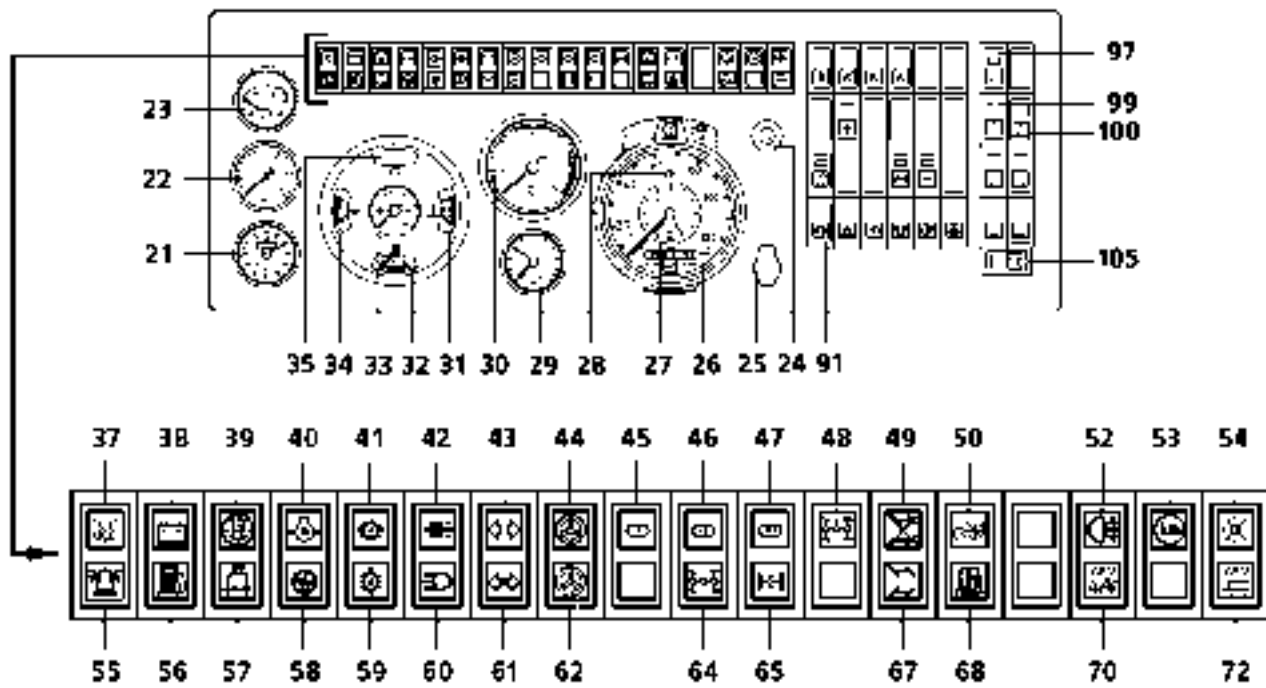

Switch on main battery switch.**Close parking brake (hand brake)**

With the brake closed, the hand lever points upwards, indicator light (35) lights.

Note: To close the parking brake, pull out the hand lever in the lengthwise direction of the lever until it engages and move it upwards.

Switching to the driving mode from the driver's cab

Switch the change-over switch (15) to the position "chassis".

CAUTION: This must only be done with the engine at a stand-still.
Before switching, the parking brake in the driver's cab as well as in the crane cab must be engaged.

When the brake is closed, the hand brake levers in the driver's cab and the crane cab point upwards.

Note: If the change-over switch (15) is activated with the engine running, the engine switches off automatically.

Switch on the ignition, Engine at standstill**Instrument check**

Switch (97) must be switched off, both axles must be suspended.

Insert the key into the ignition (24) and turn one notch clockwise.

The following indicator and warning lamps will come on:

- Preheater indicator light (37),
- Battery charge (38),
- Engine oil pressure (40),
- Oil pressure in on-load shift gearbox too low (41),
- Parking brake (35),
- Steering circuits I and II (44 and 62),
- Brake circuits I, II, III (45, 46, 47),
- Coolant level (57),
- Fuel level (56).

Note: If the air pressure in the individual brake circuits falls below approx. 5 bar, the warning lamps (45, 46, 47) come on.
Fuel and coolant must be refilled before starting the engine if the warning lamps (56 or 57) come on.

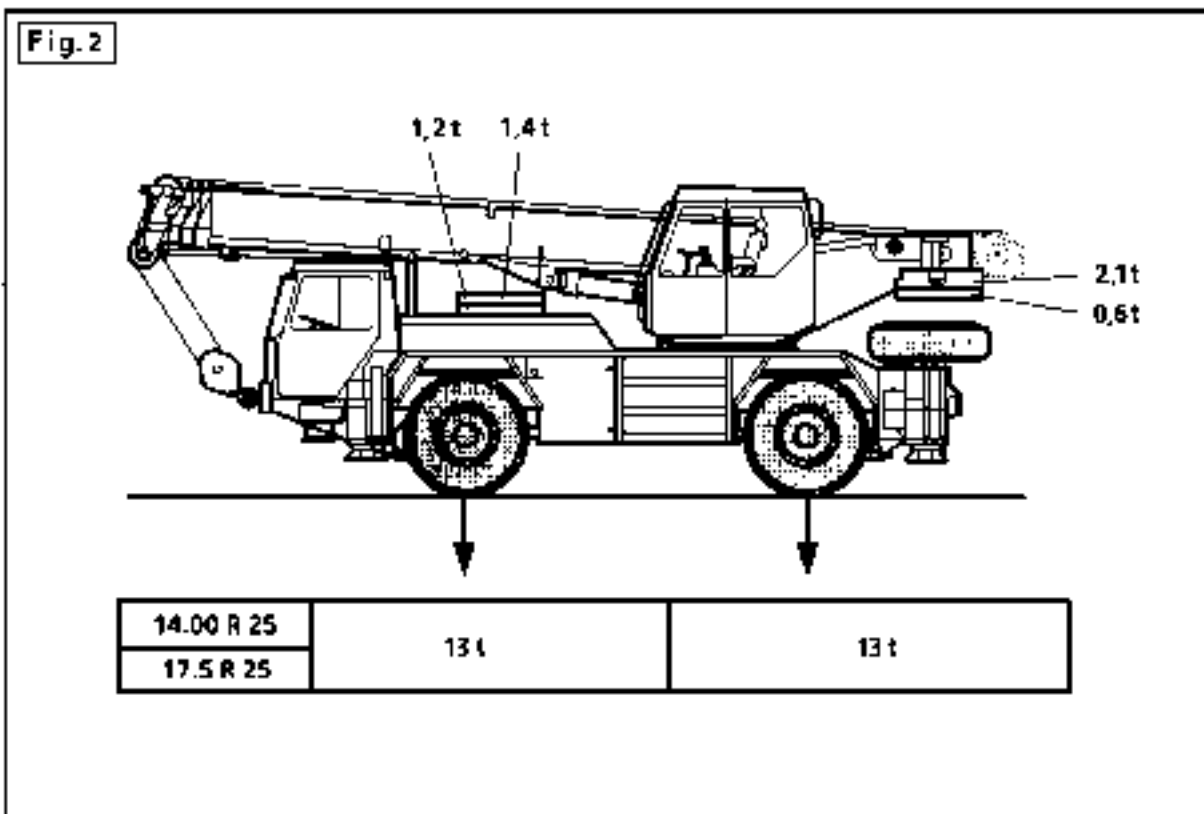
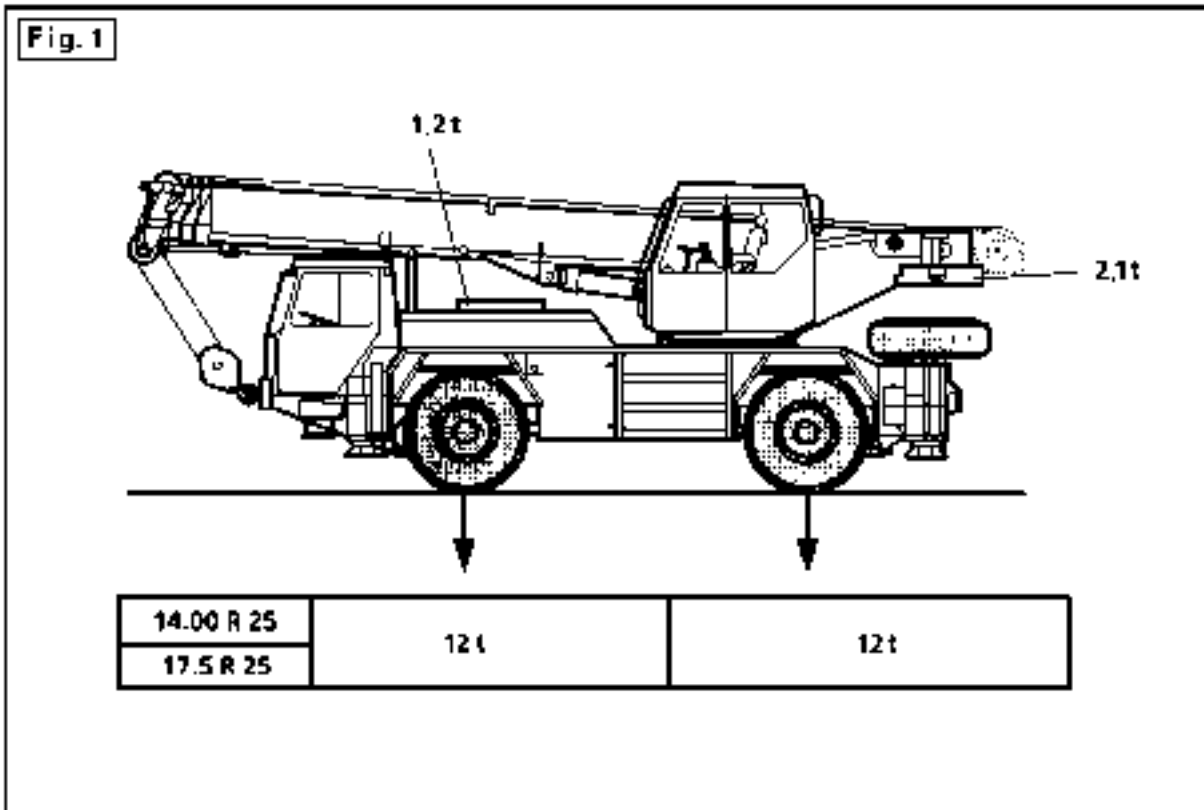

Travel condition of the crane for driving on public roads

Before driving the crane on public roads or highways, the counterweight must be distributed according to the illustration shown to conform to regulations issued by the StVZO. In foreign countries, you must check and follow all applicable state and local regulations.

Axle load 12 t / axle Fig. 1:

- The folding jib is folded in.
- The 1.2 ton counterweight is placed on the vehicle and locked.
- The 2.1 ton counterweight is attached to the slewing platform.
- The hook block is attached to the front bumper coupling.
- The spare wheel is placed on vehicle rear.
- The telescopic boom placed on the front of the crane in lengthwise direction of the vehicle, the crane superstructure is locked to the crane chassis.

Note: A hook block (single or triple pulley) may only be attached on the front if it is

- maximum 4-fold reeved,
- the letter "E" for "Entschärft" (rendered safe) has been marked on the data tag by the manufacturer and
- the oval ring intended for that purpose has been attached to the front bumper coupling and tightened.

CAUTION: If a 2nd hoist gear is installed, the rear axle load will increase by 750 kg.

DANGER: The 1.2 ton counterweight must be placed on the vehicle and must be fully locked. The 2.1 ton Counterweight must be attached to the slewing platform with four with four M 24 x 130 screws.

Axle load 13 t / axle fig. 2:

- The folding jib is folded in.
- The 1.2 ton and 1,4 ton counterweight is placed on the vehicle and locked.
- The 2.1 ton and 0,6 ton counterweight is attached to the slewing platform.
- The hook block is attached to the front bumper coupling.
- The spare wheel is placed on vehicle rear.
- The telescopic boom placed on the front of the crane in lengthwise direction of the vehicle, the crane superstructure is locked to the crane chassis.

Note: A hook block (single or triple pulley) may only be attached on the front if it is

- maximum 4-fold reeved,
- the letter "E" for "Entschärft" (rendered safe) has been marked on the data tag by the manufacturer and
- the oval ring intended for that purpose has been attached to the front bumper coupling and tightened.

CAUTION: If a 2nd hoist gear is installed, the rear axle load will increase by 750 kg.

DANGER: The 1.4 ton counterweight must be attached with one M24 x 160 screw on the 1.2 ton counterweight, because only the lower counterweight can be locked to the vehicle. The 2.1 ton counterweight must be attached to the slewing platform with four M 24 x 130 screws. The 0.6 ton counterweight must be attached to the 2.1 ton counterweight with two M 30 x 140 screws.

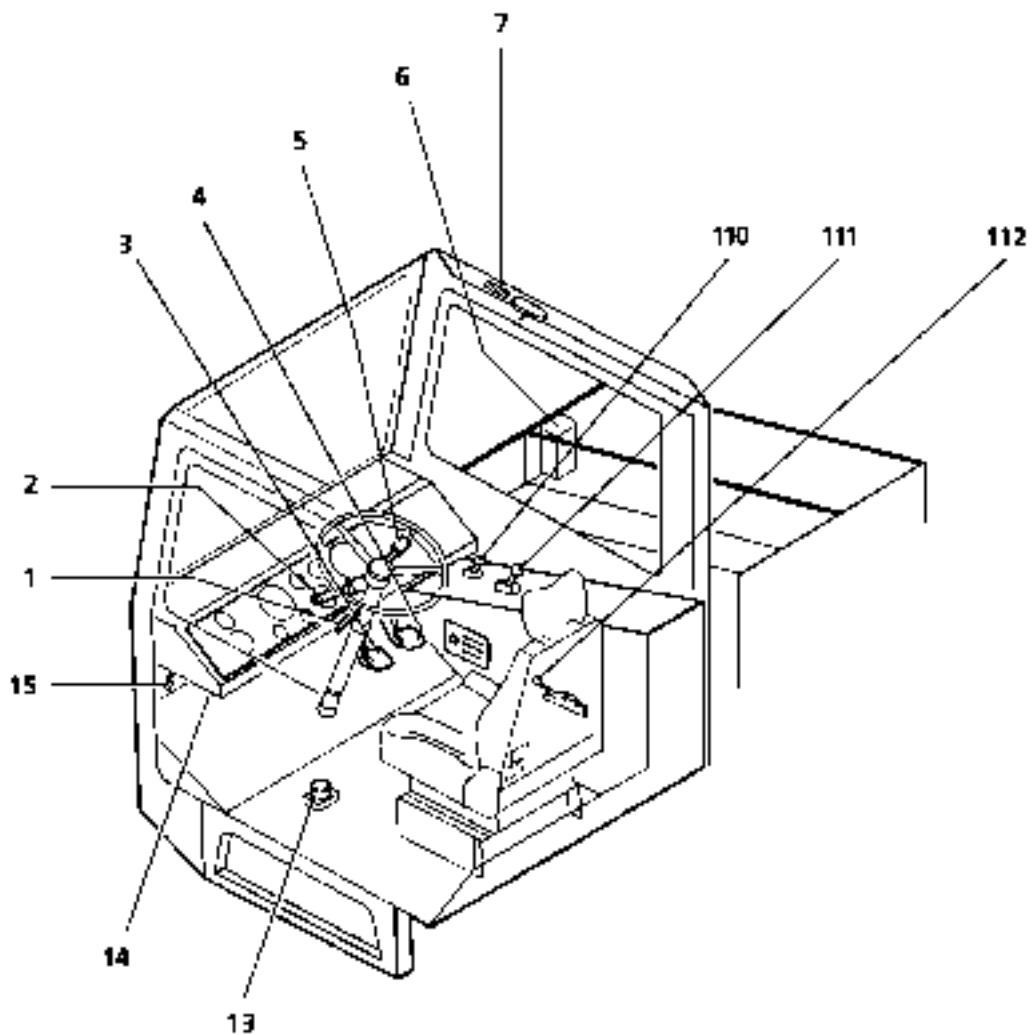
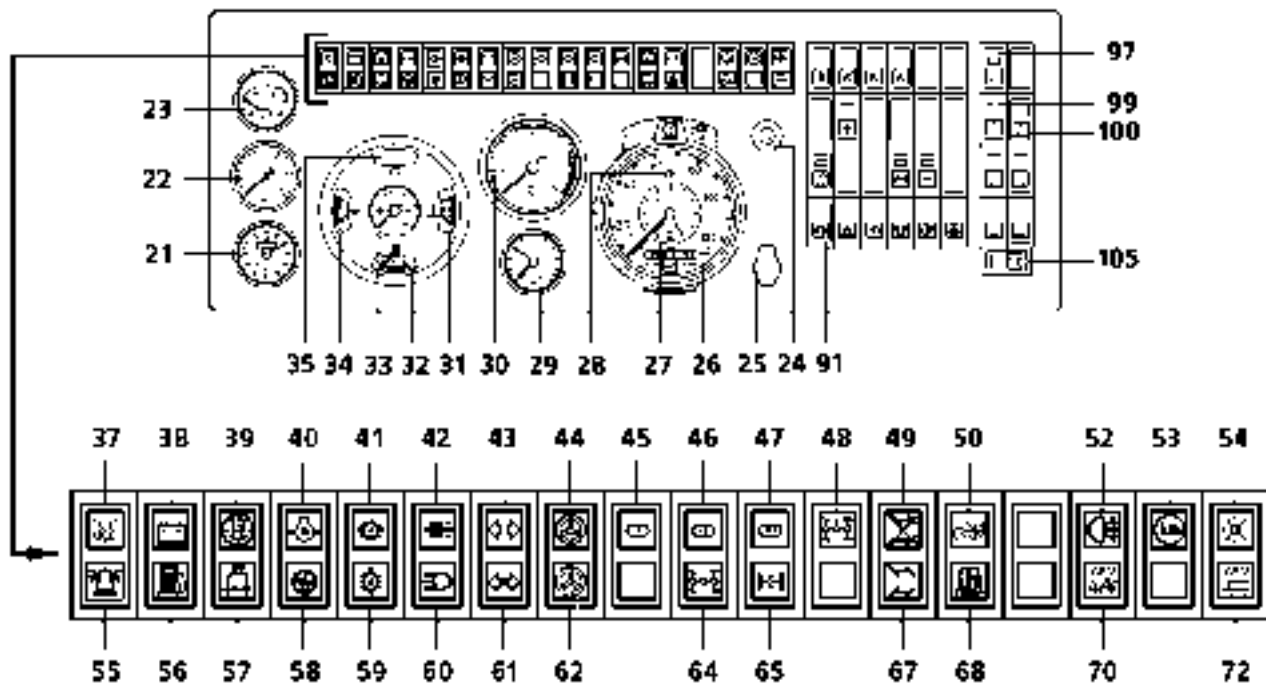

Gear selector switch

Switch gear selector switch (111) to "N" neutral position.

Note: The engine can be started in position "N" only.

Start the engine

CAUTION: The engine can only be started when the preheater indicator light (37) blinks.

Starting with the flame glow device

If the outside temperature is below zero, always start using the flame glow device, allowing a longer preheating time.

This not only lowers the starting limit temperature, but also makes starting easy at temperatures which do not quite require the use of a starting aid agent.

The option of afterignition to avoid smoke when starting is also provided, if engine is started from the very beginning using the flame glow device ("preheating").

Note:

- a) If the coolant temperature is over +20 °C, and flame glow device is switched off (automatically)!
- b) If the flame glow plug fails, the preheater indicator light (37) **does not** light.

Starting procedure at temperatures under 0 °C**1. Preheating**

When the ignition/start switch is switched to position "1" (driving), the preheating interval of ca. 40 to 50 sec. begins.

The preheating interval is displayed by indicator light (37) blinking.

If the engine is started during the preheating interval, the preheating procedure is automatically interrupted.

In this case, repeat preheating.

2. Starting the engine

After the preheating interval, indicator light (37) shuts off and the start readiness interval of ca. 30 sec. begins.

The engine is started by turning the ignition/start switch further to position "2" (start).

The charge indicator light (38) must light up.

Note: Start the motor without activating the accelerator pedal.

If the engine is **not** started during the start readiness interval, the start readiness interval is automatically over. In this case, repeat points 1 and 2).

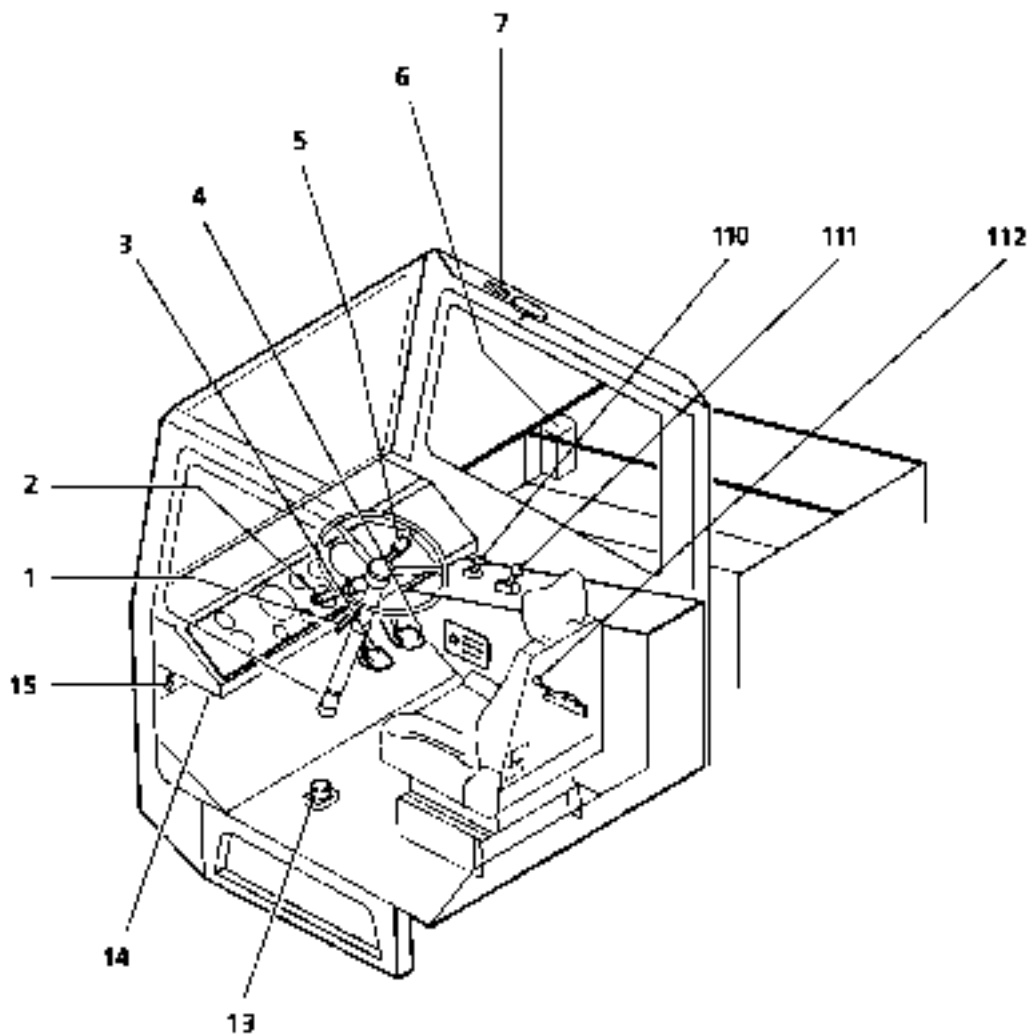
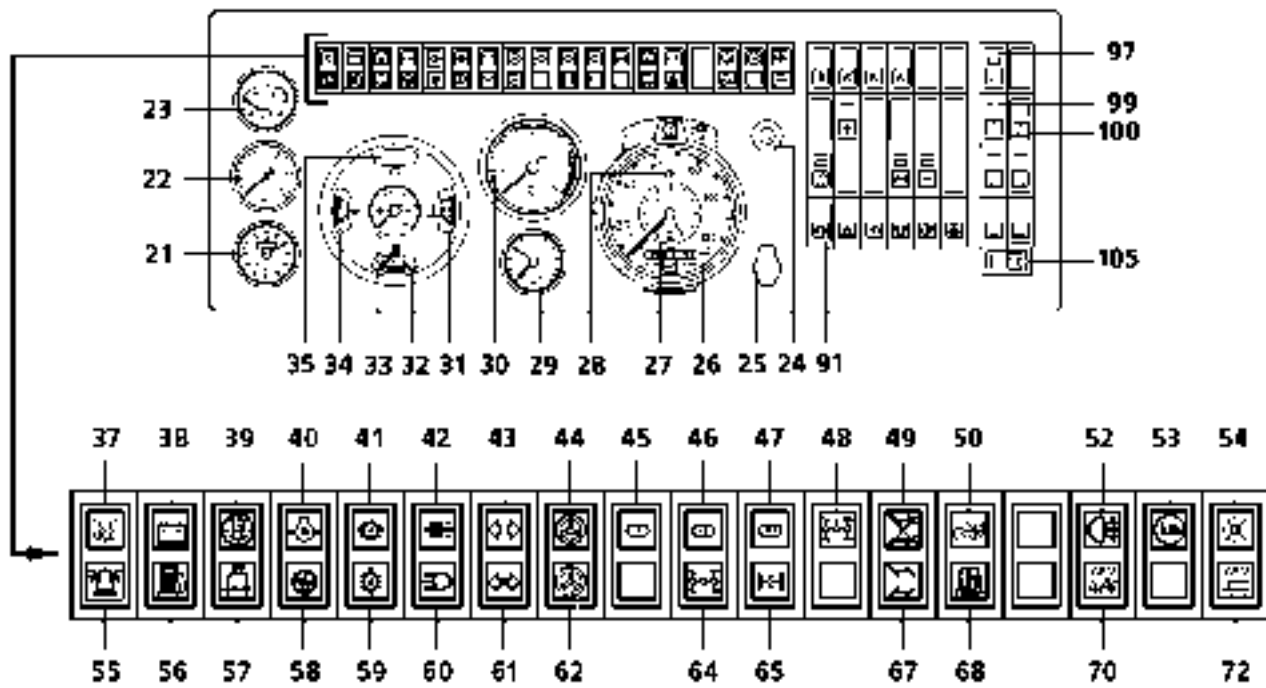

If after ca. 5 seconds the engine doesn't start, slowly depress the engine regulator accelerator pedal.

If after ca. 20 sec. the starting procedure is still unsuccessful, allow a 1 minute pause.

The starter can be activated for 3 x 20 sec. per starting procedure, with one minute pauses between attempts.

Observe the oil pressure warning light (40) immediately after starting the engine.

CAUTION: If the warning light (40) does not shut off, or if it lights up during crane operation, shut off the engine immediately.

If this is not done, the engine may sustain damage due to too low oil pressure.

The engine must be shut off immediately if:

- the oil pressure sinks or varies severely,
- the power and speed sink without the position of the control setting lever being changed,
- the exhaust is particularly smoky or the exhaust manifold temperature rises.
- the coolant water and oil temperatures rise,
- abnormal noises are suddenly emitted from the motor or the turbo-supercharger.

When starting the engine warm, do not depress the accelerator pedal; this guarantees a smokeless start.

Engine running - instrument check

Observe the oil pressure gauge (34) and the warning lamp (40) immediately after starting the engine.

CAUTION: If the oil pressure is zero or if warning lamp (40) does not come on, switch off the engine immediately - if this is not done, the engine could be damaged.

The following indicator lamps must go out while the engine is running:

- Battery charge (38)
- Engine oil pressure (40)
- Steering circuit I (44)
- Steering circuit II (62)

Note: The indicator lamp of steering circuit II (62) only goes out once driving begins.

- Brake circuit I (45), II (46), III (47)

Note: The indicator lamps of the brake circuits do not go out until a pressure of approx. 5 bar has built up in the brake system.

Shutdown pressure is approx. 8,5 bar.

The parking brake (110) can only be released once the air pressure in brake circuit III has built up to approx. 5.2 bar. The indicator lamp (35) then goes out.

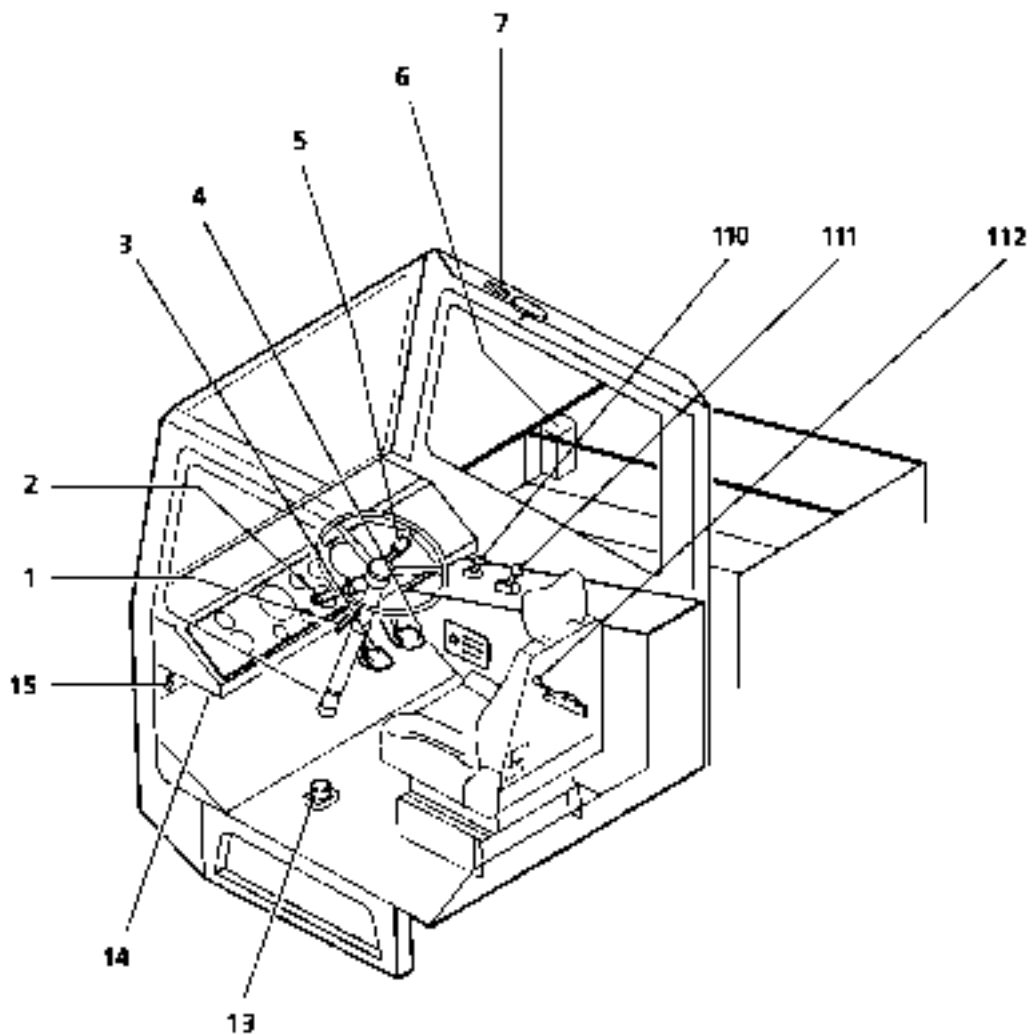
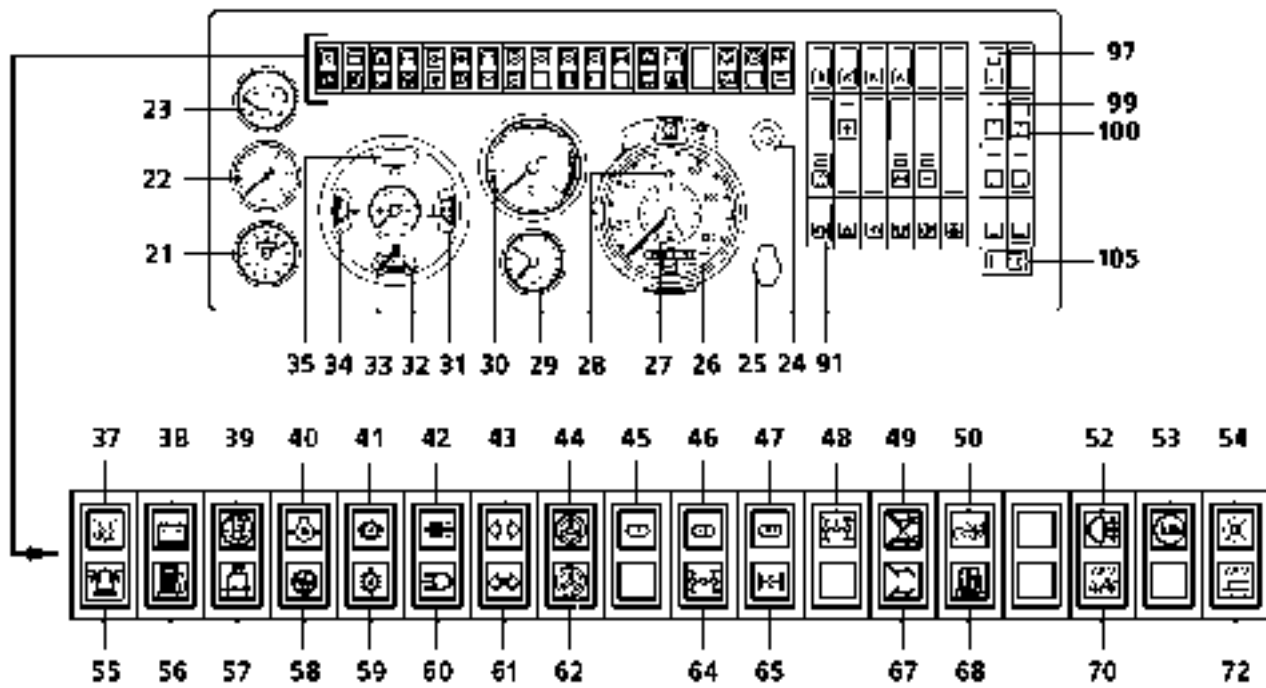

3. Shutting off the engine

Relieve load on the engine, Reduce the engine speed gradually, so as to avoid overheating the coolant, then allow the engine to run for a short time at idle speed.

This should be observed particularly for supercharged engines, while this gives the turbo supercharger, which is running at high speed, a certain amount of time to run down.

If the engine is shut off suddenly, the turbo supercharger runs for a while without oil supply.

Shut off the engine using button (91).

Checking the service brake system

To check operation of the service brake system, slowly depress brake pedal (3). The red needles in the duplex air pressure gauges (29, 33) must move in proportion to pedal movement until they show the same readings as the white needles (reservoir pressure).

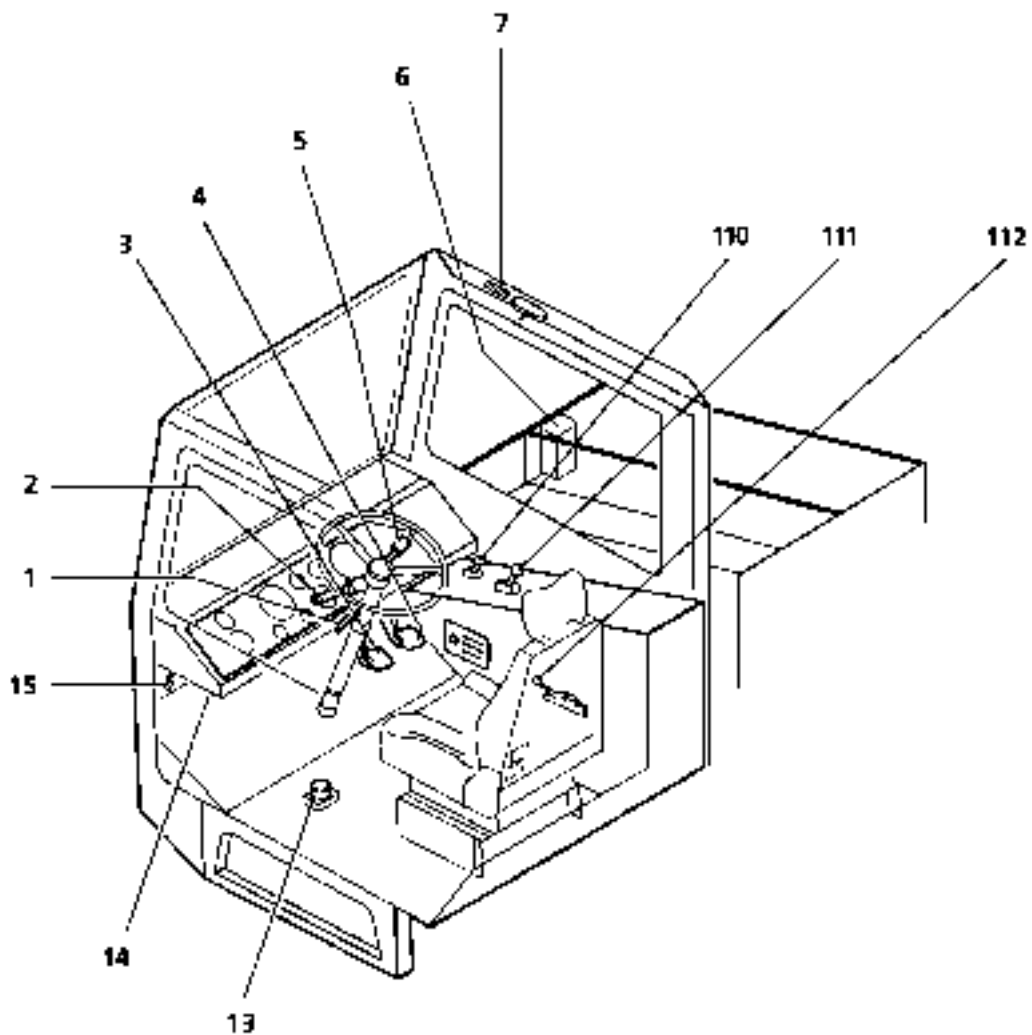
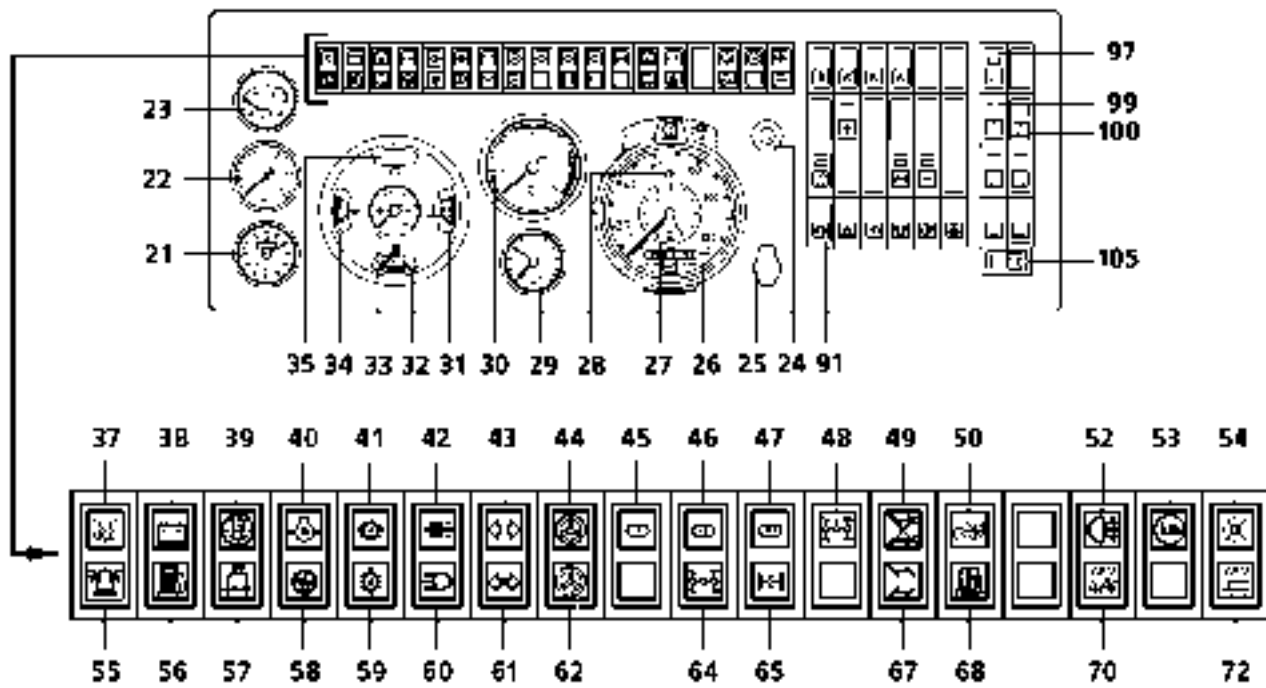

Adjusting axle suspension

Switch (97) must be switched off; indicator lamp in the switch is not on.
In this position, all axles are suspended.

Note: See Chap. 3.03 for a description of the **AXLE SUSPENSION/LOCKING SYSTEM**.

Automatic levelling control

Note: Automatic and manual levelling must always be carried out on level ground!

Push button (99) NIVEAU for automatic levelling until indicator lamp NIVEAU (100) comes on. The prescribed level (driving height) is now adjusted.

The indicator lamp NIVEAU (100) is on as long as button (99) is activated.

Manual levelling control

CAUTION: **Manual levelling on public roads is only permissible under special circumstances, such as lowering the crane in order to achieve the proper clearance to drive under a bridge.**

Preparing to move off - engine running at idle

Select the desired range on the gear selector (111).

Note: A slight drop off of engine rpm signals that the selected gear is engaged.

Release parking brake

Pull out the hand lever (110) fully outward on its longitudinal axis and push out forward. Indicator lamp (35) goes out.

Note: When the parking brake is released, the hand lever points forward.

CAUTION: **As long as the required brake release pressure (approx. 5.2 bar) in brake circuit III is not available - warning lamp (47) is on - the parking brake cannot be disengaged, even if the hand lever is pushed forward.
Bring the hand lever to the rear and let the brake circuit III recharge until indicator lamp (47) goes out.**

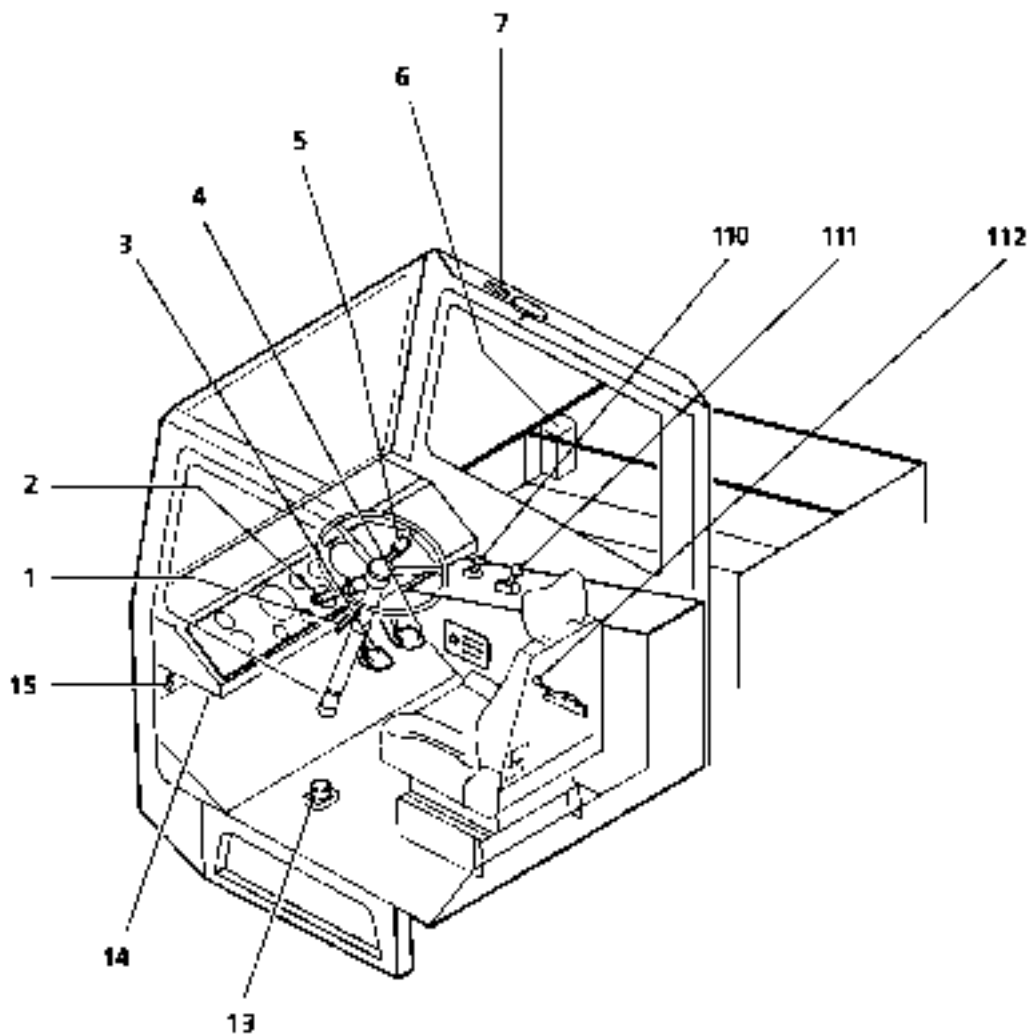
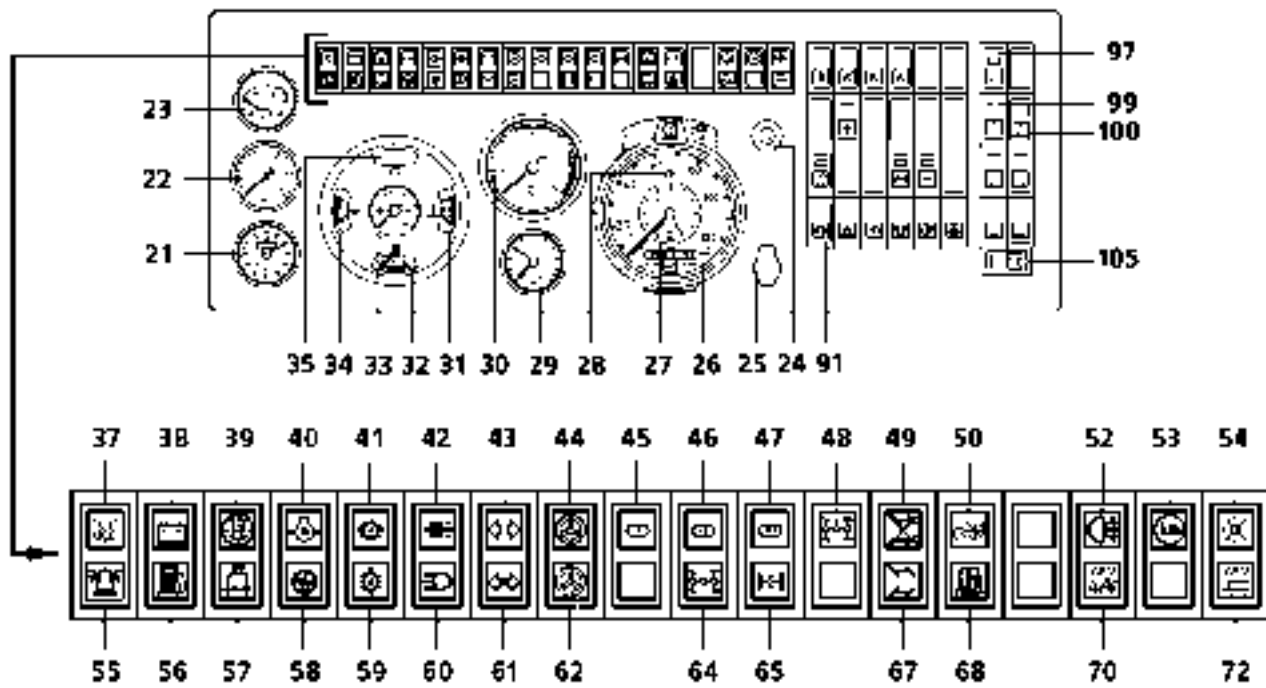

Service brake

Increase engine rpm with foot pedal (4). The crane will begin to move.

CAUTION: The brakes must be checked as soon as the journey begins.

Engine brake

With the foot button (13), the wear-free engine brake can be applied as required.

DANGER: On a downhill grade, only the engine brake may be used. If the braking power proves to be insufficient, the vehicle must be slowed down with the service brake until the transmission can down-shift.

Eddy current brake *

The 5-position steering column switch (5) can be used to activate the eddy current brake, if required. This is indicated by lamp (50).

CAUTION: The steering column switch must be returned to ZERO (forward) as soon as the vehicle is at a standstill, or when the brakes are no longer needed.

Emergency release valve for parking brake (manual brake) *

If the parking brake is blocked due to a defect in the air pressure system, then it can be vented (released) by pressing the button (113) * and the vehicle can be moved from the danger zone.

DANGER: It is not permitted to continue to drive the vehicle if the air pressure system is defective.

Driving on a downhill gradient

In order to protect the service brake, the driving speed should be held in check by using the engine brake and the eddy current brake *.

Note: A simple rule of thumb:
A downhill grade should be driven in the same gear as that used to drive the same grade uphill.

CAUTION: Driving too quickly on a downhill grade can overload the engine brake. If this happens, a constant speed can no longer be maintained and at the same time, oil temperature exceeds its upper limit of 120 °C. In this case, the vehicle must be slowed down with the service brake to the point that a further downshift is possible. (During braking, select the next lowest operating range).
If the speed is matched to the incline as described above, the retarder can brake the vehicle constantly without danger of overheating

* Optional

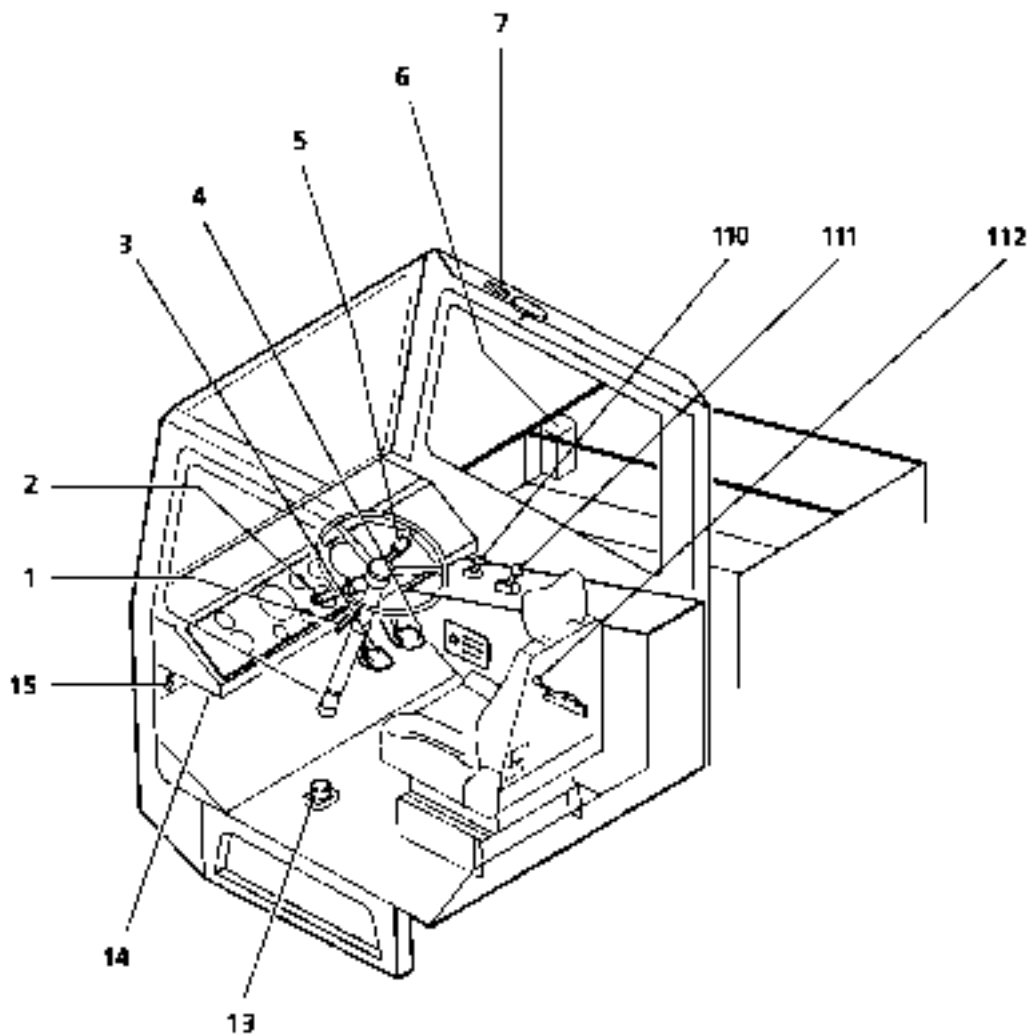
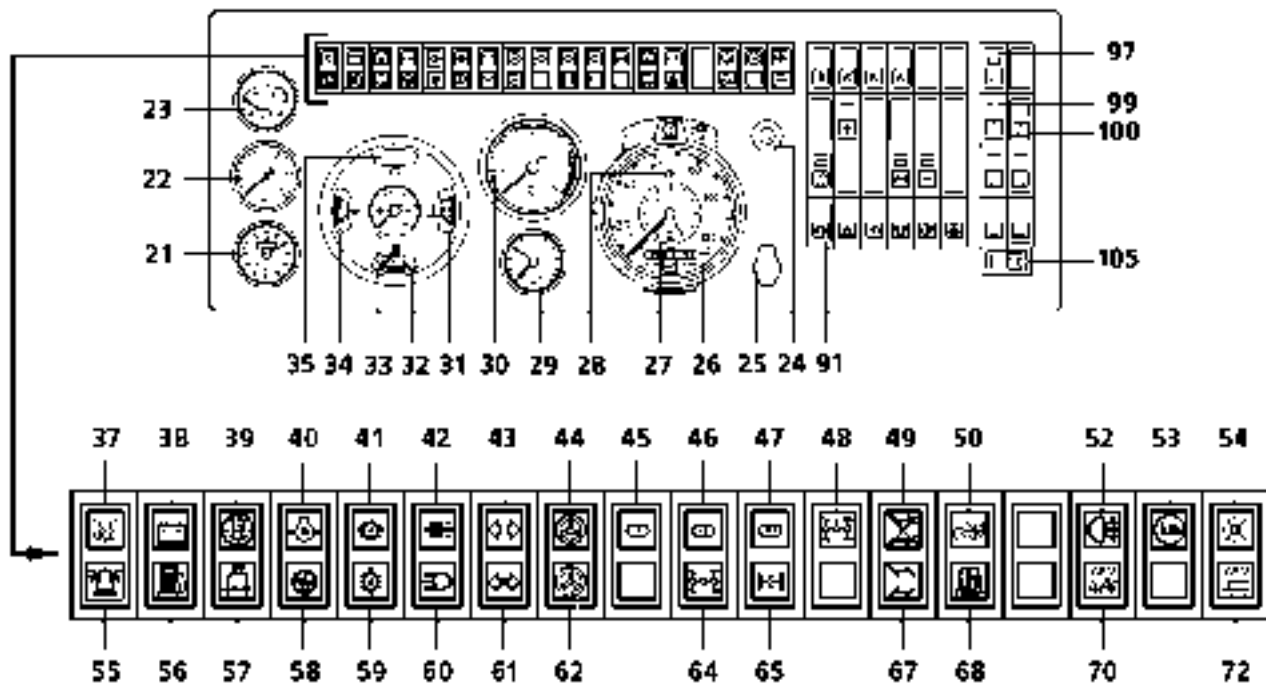

Readying the vehicle for driving

Motor is running at idle speed.

Select level 1 with the gear selector switch (111) (forwards or backwards, as required).

Release the hand brake. With the hand brake open, the hand brake lever points forwards.

To release the hand brake, pull out the switch block in the lengthwise direction of the hand lever and rotate the hand brake lever forward.

The crane will now begin to move slowly.

Shifting

There are 6 forward gears and 2 reverse gears available for driving the crane from the driver's cab.

The driving speed controlled using the accelerator pedal (4) and the on-load shift gearbox gear selector switch (111).

The various gears can be shifted into under load.

To protect the engine from overspeed, shift down only when the maximum speed of the lower gear is reached. If necessary, slow the crane to this speed with the service brake.

Braking

Test the brakes immediately after starting to drive.

Driving operation

The following instruments, which are important for driving operation, should be observed while driving:

1. Oil pressure warning light (40).

If this light comes on while underway, and doesn't shut off when engine speed is increased, the crane must be brought to a stop and the engine must be shut off.

2. Warning light coolant temperature too high (58).

If this light comes on while underway, first try to get the temperature into the proper range and thus shut off the light by reducing load on the engine and raising the engine speed.

If this does not work, bring the crane to a stop and shut off the engine.

3. Warning light torque converter/power shift gearbox oil pressure (41).

If this light comes on while underway, bring the crane to a stop and regulate the engine speed to ca. 1500 rpm. If the warning light does not shut off within a short period of time, shut off the engine. If the light comes on briefly while shifting, no action need be taken.

4. Warning light torque converter/power shift gearbox oil temperature (59).

If this light comes on while underway, bring the crane to a stop and regulate the engine speed to ca. 1500 rpm. If the warning light does not shut off within a short period of time, shut off the engine.

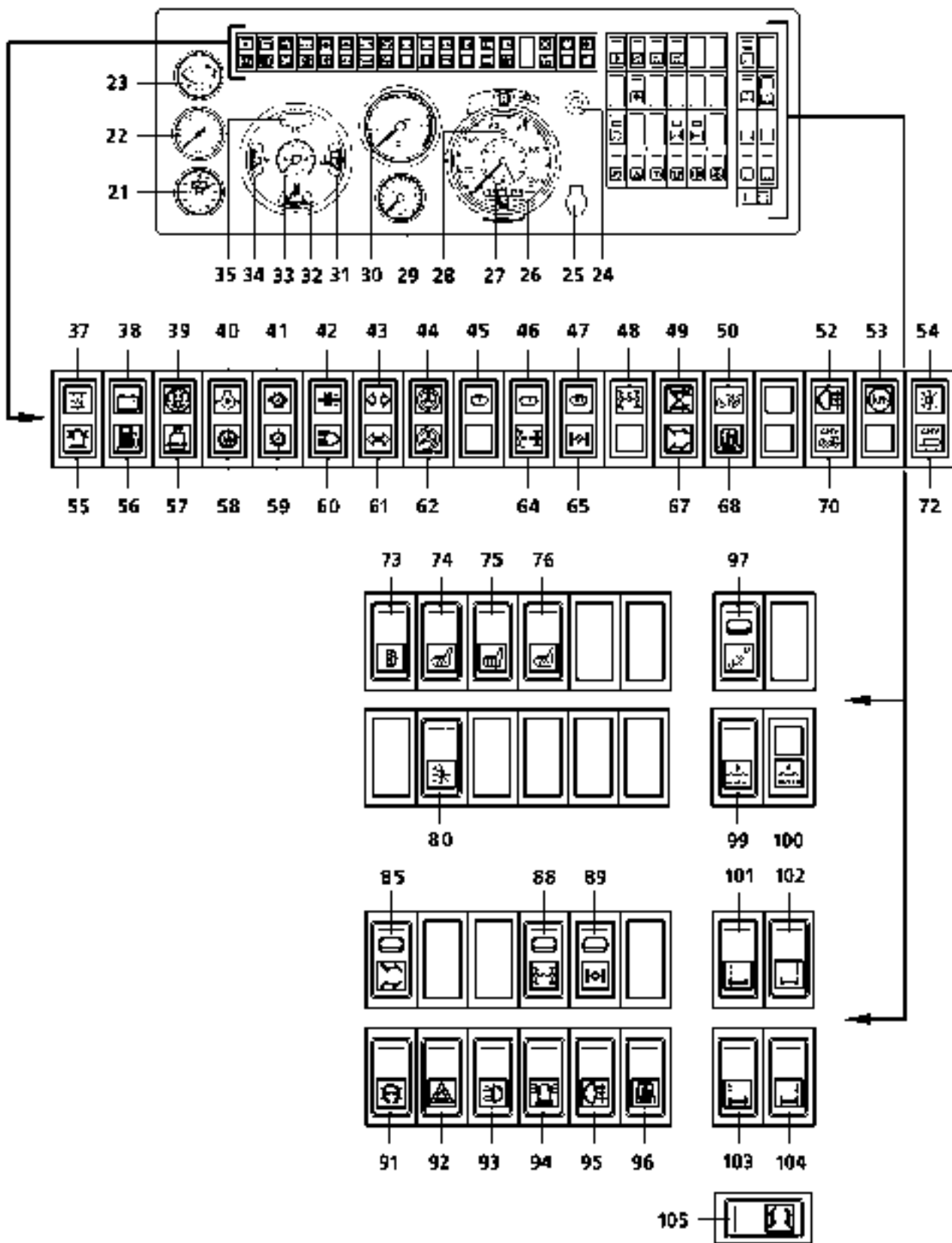

5. Warning lamp - Steering circuit II (62)

Warning lamp (62) for the hydraulic steering circuit II must go out once a speed of approx. 10 km/h is reached.

CAUTION: If this warning light does not go out, steering circuit II is not functioning properly and the crane must be brought to a standstill immediately. The cause of the defect must be rectified.

6. Diesel engine oil pressure gauge (34)

CAUTION: If the oil pressure falls while driving and fails to increase again as engine speed rises, the crane must be brought to a standstill immediately and the engine switched off.

When little or no oil pressure is indicated, there is no engine lubrication. This can lead to engine damage.

7. Warning lamp - engine oil pressure (40), warning lamp - coolant temperature (58)

CAUTION: If the warning lamps (40, 58) come on while driving, the crane must be brought to a standstill immediately. If there is too little oil pressure and/or the engine temperature is too high, there is the danger of damage to the engine.

8. Coolant temperature gauge (31)

If the temperature becomes too high while driving, try to lower it to within the permissible range between 85 °C to 90 °C by first reducing the load and increasing the engine rpm.

CAUTION: If the coolant temperature cannot be lowered to the permissible range, the crane must be brought to a standstill immediately and the engine switched off. If the engine temperature is too high, the engine may be damaged.

9. Torque converter oil temperature gauge (23)

The needle of the temperature gauge (23) must be in the permissible range (green) while driving.

When braking with the **retarder brake**, The pointer can drift briefly into the yellow range of the scale.

CAUTION: If the needle goes into the red range, the crane must be brought to a standstill. Shift into "N" and let the engine run at approx. 1500 rpm. The oil temperature must then fall back into the permissible temperature range within a short time. If this does not happen, the crane must be brought to a standstill immediately and the engine switched off. If the temperature is too high, the transmission may be damaged.

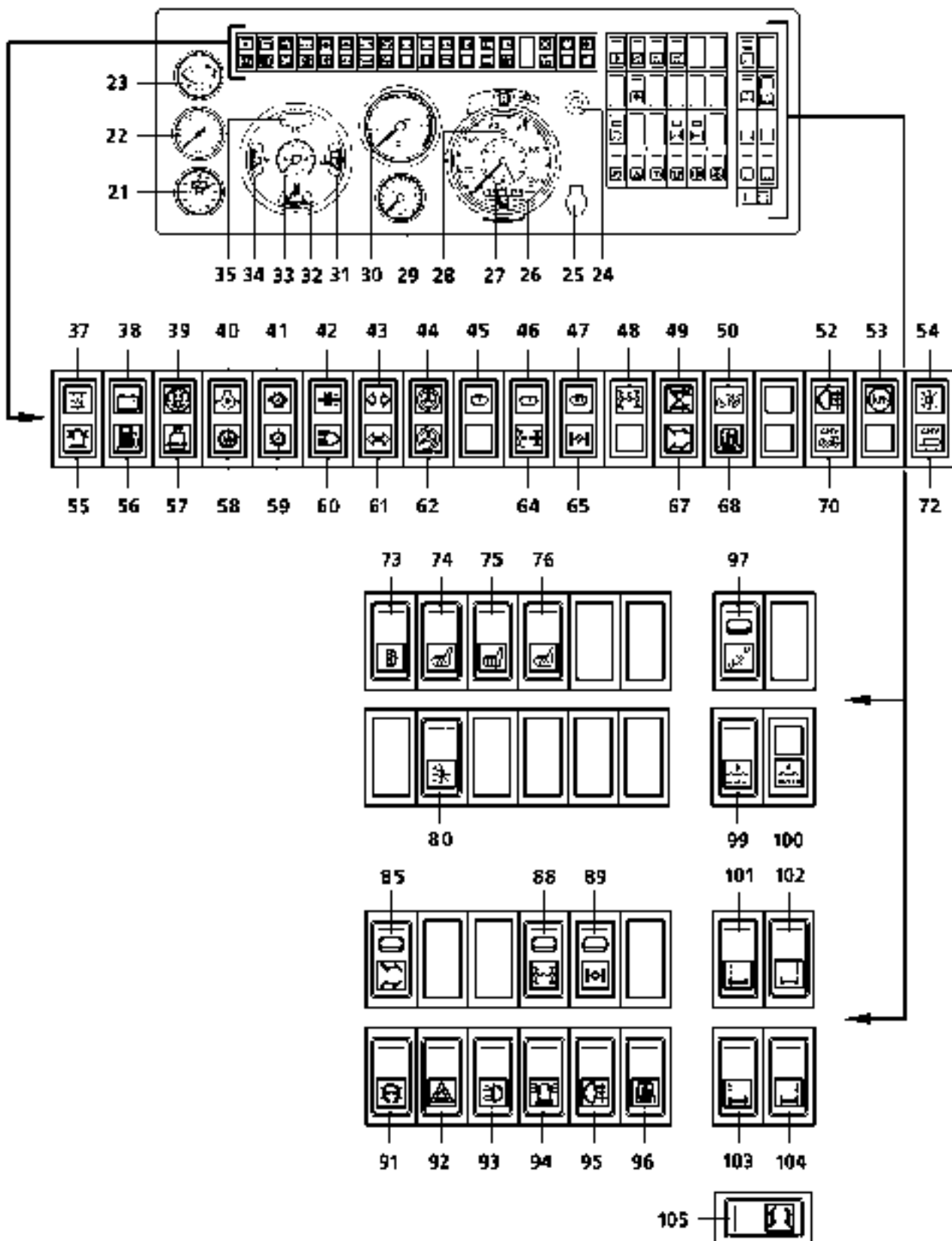

6. Torque converter oil pressure gauge (22)

While driving forward, the oil pressure is approx. 15 bar.

CAUTION: If there is a dramatic fall in the oil pressure, the diesel engine must be switched off immediately.

7. Indicator lamp - converter bypass clutch / LOCK UP (42)

When, at increasing speed, the output speed of the torque converter is almost equivalent to its input speed, as travel speed increases, i.e., when the converter can no longer achieve any increase in traction, the converter bypass clutch engages automatically and indicator lamp (42) goes out.

Note: You should always drive so that indicator lamp (42) comes on as little as possible; this guarantees economical driving.

8. Fuel gauge (32)

The amount of fuel in the tank is indicated; refill as required.

CAUTION: The crane must never be driven until the fuel tank is empty as residue and dirt can be ingested - if this happens, the fuel system must be cleaned and ventilated. Never drive to the point where the fuel level warning lamp (56) comes on; always tank when necessary.

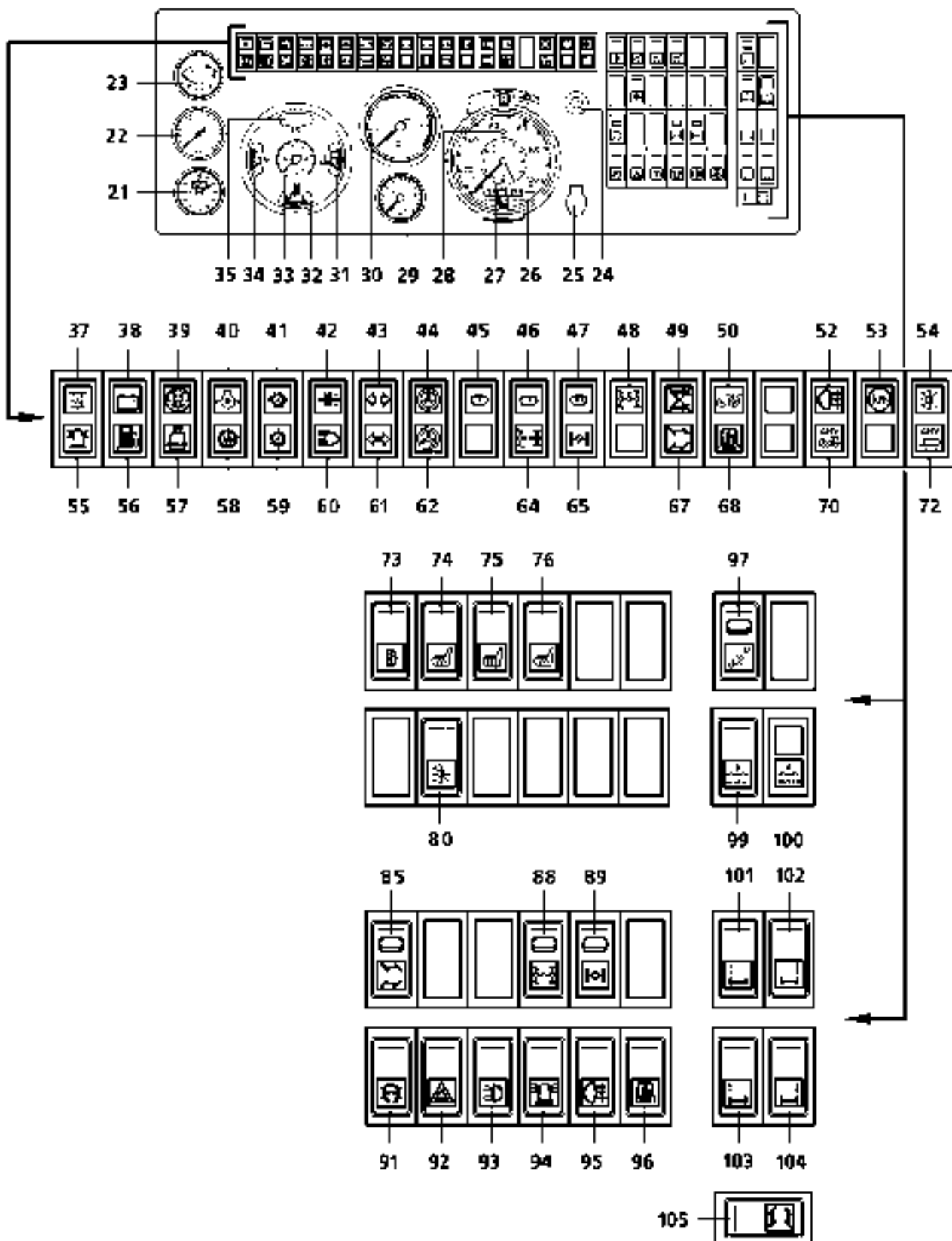

Off-road driving

For off-road driving, driving on unpaved surfaces, and during winter conditions, additional gears are provided which may only be shifted to in the following order with the crane at a standstill:

1. 1st axle drive
2. transverse differential locks

Note: The forward axle can be switched separately.
Forward axle drive is required for the axle differential blocks.

1. Switching on the forward axle drive

As soon as one or both wheels begin to slip, the forward-axle drive can be switched on using switch (88).

Note: Move off carefully.
Front axle drive is only engaged once indicator lamp (64) is on.

2. Switching on the axle differential blocks

If switching to forward axle drive proves insufficient, the transverse differential locks of the 1st and 2nd axles can be switched on with switch (89).

Switch on the 1st and 2nd axle differential blocks, switch (89).

Note: Move off carefully.
Transverse differential locks are only engaged once indicator lamp (65) is on.

CAUTION: These may only be switched on with the vehicle and a standstill and the gear selector switch in neutral position.
Move off carefully. The forward axle drive and transverse differential locks are engaged as soon as the indicator lamps (64 and 65) come on.
As soon as the front axle drive, as well as the axle differential locks are no longer absolutely required to continue driving (on firm surface providing traction), they must be switched off again immediately.
Driving on a solid surface with good traction with the front axle drive and differential locks engaged can cause considerable damage to the driven axles and the whole drive train!

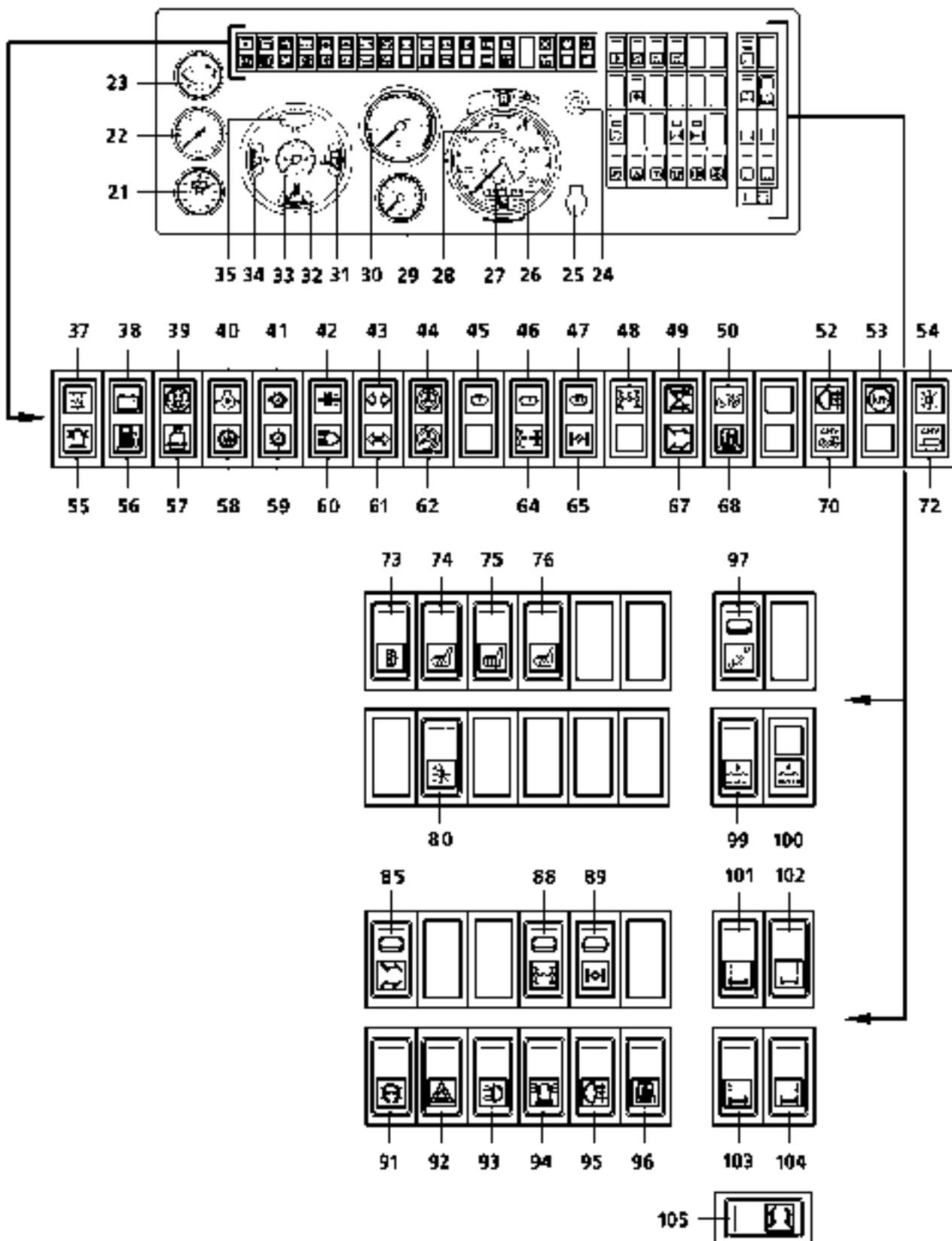

Rear-axle steering

The rear axle steering makes it possible to lock in the 1st and 2nd axle wheels in the same direction, allowing the crane to move sideways (crabbing motion) and turn in a tight radius.

CAUTION: Rear-axle steering must not be engaged or operated on public roads. The indicator lamps (49 and 67) which indicate rear-axle steering must be out when driving on public roads. The steering direction of the rear-axle must be checked by observing the rear wheels.

Putting the hydraulic rear-axle steering into operation

- Bring the vehicle to a standstill on even ground.
- Steer the wheel for straight travel.
- Engage neutral on gear selector.
- Open the rear axle steering lock via switch (85).

Note: Release is possible in neutral, in 1st and 2nd forward gears as well as in 1st reverse.

- Lightly move steering button (105) left and right until the yellow indicator lamp (67) comes on.

Note: If warning lamp (67) comes on instead of indicator lamp (49), the steering lock/release is in an intermediate position. In this case, switch (85) must be switched off and on again and the steering button (105) must be moved lightly to the left and right until the indicator lamp (67) comes on.

- Via the steering button (105), the rear axle can now be steered left or right independently of the two front axles.

Taking out of operation

CAUTION: If rear-axle steering is no longer required, it must be engaged on even ground immediately before continuing operations or the journey!

- Bring the vehicle to a standstill on even ground.
- Bring the wheels to straight travel position.
- Close steering lock of the rear axle via switch (85).
- Move rear axle steering left and right until indicator lamp (67) goes out.
- Make sure that rear-axle steering is locked; i.e., again activate rear-axle steering with steering button (105) while watching the wheels of the rear axle: steering must no longer be possible.

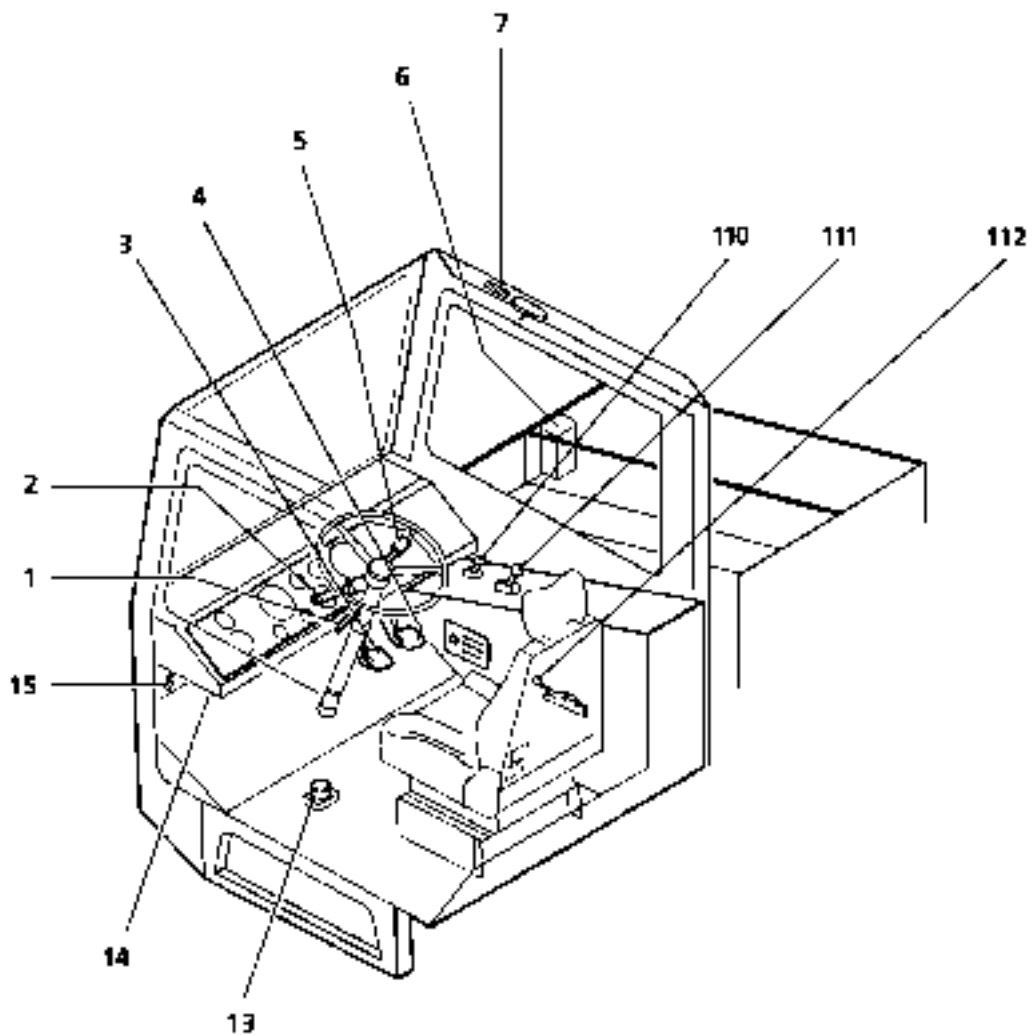
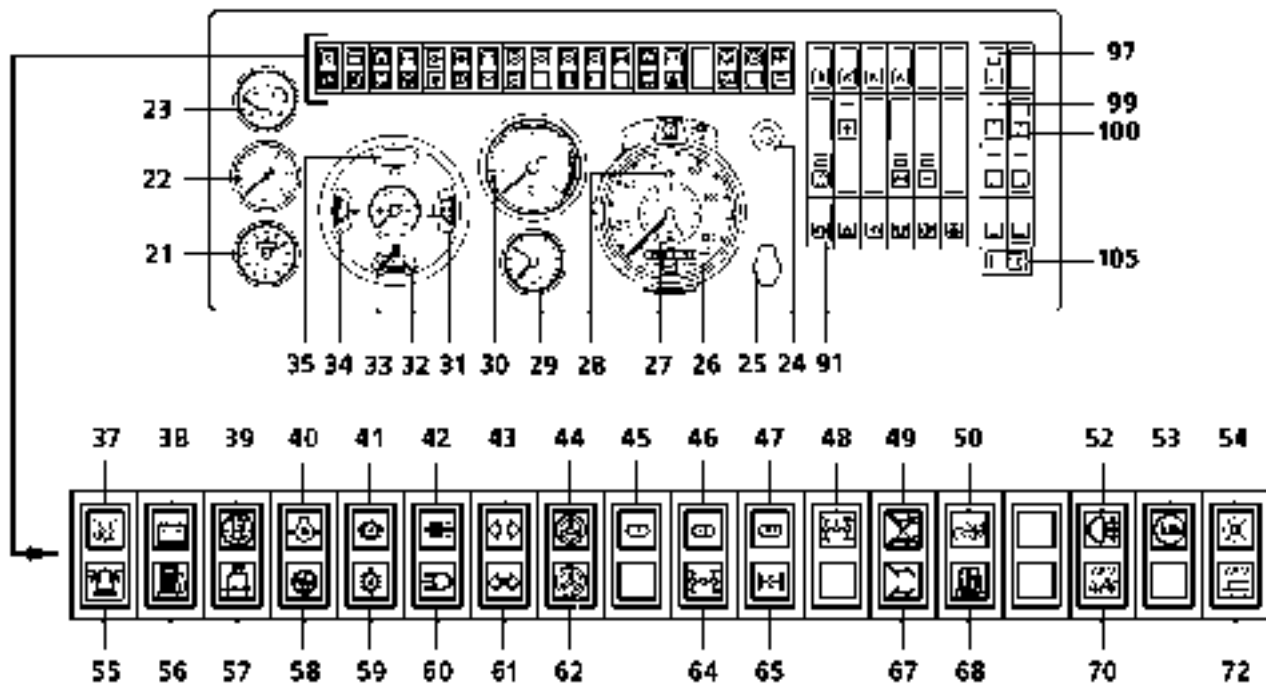

Stopping in traffic

Bring the crane to a standstill with the service brake.

The driving range on the gear selector (111) can remain engaged.

Interrupting the journey with the engine running

Bring the crane to a standstill with the service brake (3).

Before leaving the driver's seat, the gear selector (111) must be switched to the neutral position "N".

With manual lever (110), engage the parking brake - indicator lamp (35) must be on.

Ending the journey

Brake the crane to a halt.

Switch the gear selector (111) to the neutral position "N".

Engage the parking brake with the manual lever (110).

Press the Engine-cutoff foot switch (91) until the engine stops.

Switch off the ignition with the ignition key (24) - turn the key counter-clockwise to "0" and remove.

Pull the switch cam off the battery master switch.

Lock the driver's cab.

Chock the wheels to prevent the crane from rolling away.

Towing

A coupling head underneath the bumper, forward right, is provided for compressed air supply to the crane to be towed. This must be connected to the towing vehicle in order to externally supply the crane being towed.

Towing regulations

The supply pressure while towing must be at least 6 bar.

Never exceed a speed of 25 km/h when towing the crane.

The towing eye is to be secured with pins whenever the crane is towed.

Only one towing bar may be used for towing.

In the event of engine damage

1. Up to a towing distance of 10 km:
 - The towing speed may not exceed 10 km/h.
 - The air pressure system must be continually supplied with pressurized air (about 7 bar) via an external air pressure system.
2. Up to a towing distance more than 10 km:
 - Disconnect the drive shaft from the transmission to the axles and secure it.
 - The air pressure system must be continually supplied with pressurized air (about 7 bar) via an external air pressure system.

In the event of transmission damage

- Disconnect the drive shaft from the transmission to the axles and secure it.
- If the engine is also damaged, the air pressure system must be continually supplied with pressurized air (about 7 bar) via an external air pressure system.

In the event of damage to the drive axles

- Remove the drive shaft to the defective axle and secure it.
- Remove the independent axle from the defective axle.

Note: Allow only trained personnel to carry out the towing procedures if there is any damage to the drive axles.

CAUTION: During the towing procedure, the parking brake must be released otherwise the brake system will be damaged.

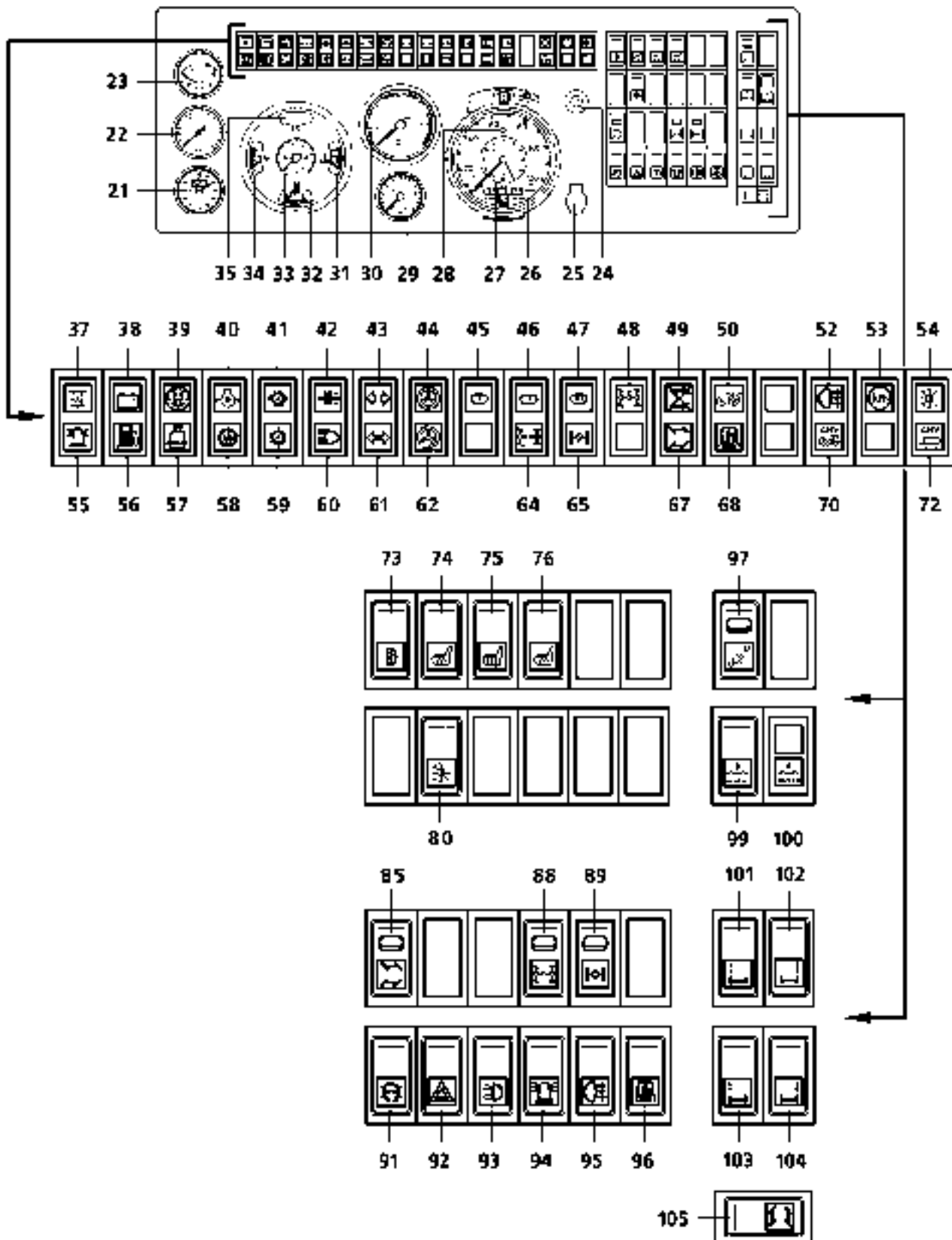

Selecting the site

Select the site so that the supports can be extended to the support base specified in the load capacity table and so that the crane can be horizontally aligned.

DANGER: The safety technical notes Chapter 2.04 must be observed and adhered to - otherwise, there is the danger of accidents.

Switching from driving to crane operation

Requirements:

- The crane is standing on an even foundation,
- the manual brake lever (110) in the driver's cab and (225) in the crane cab is engaged,
- the gear selector (111) is in position "N",
- the engine is running,
- switch (97) is off (in the position **Axles suspended**).

Locking axle suspension

- Via the manual leveling control, buttons (101, 102, 103, 104), align the crane as horizontally as possible.
- switch on "**axle suspension locking**" switch (97)
- Shut off the engine using engine shut-off button (91).

Switching over to superstructure operation

CAUTION: The motor must be at a standstill before the switch (15) is switched over; otherwise, the hydraulic pump activation coupling is damaged.

- Switch the change-over switch (15) to the position "superstructure"; indicator light (48) lights up. The axle suspension is locked automatically.

The following functions are now switched over to superstructure operation:

Steering, gear selection, hand brake, electrical system.

Note: For safety reasons, the "axle suspension locking" switch (97) should be switched on as well. If the change-over switch (15) is moved with the engine running, the engine and ignition shut off automatically.

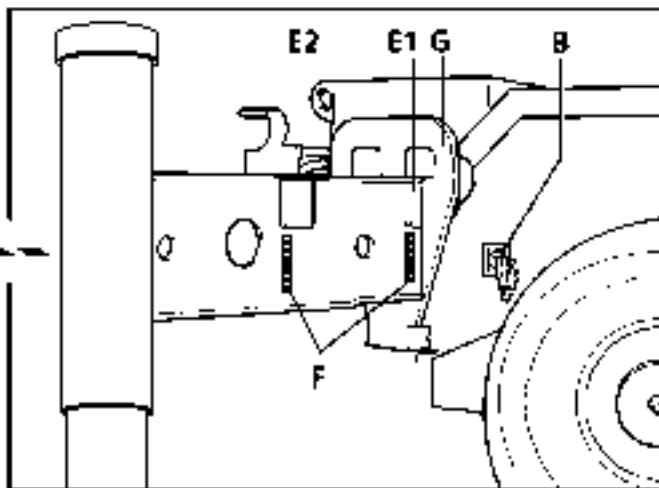
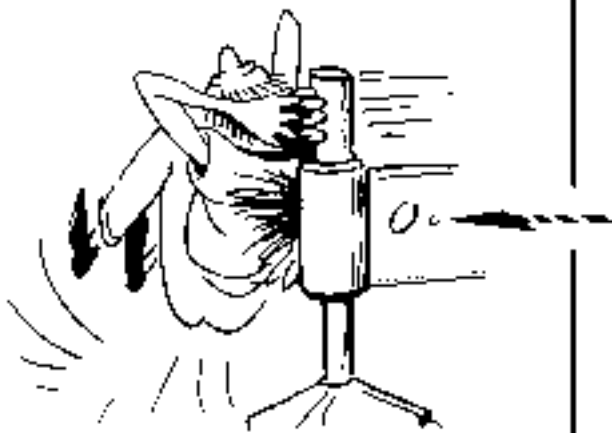
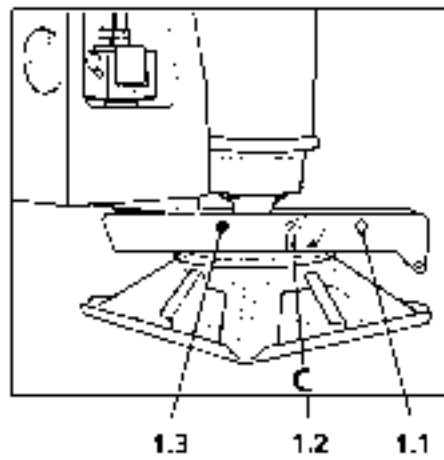
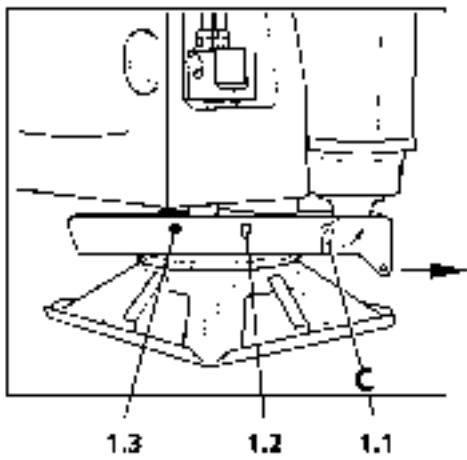
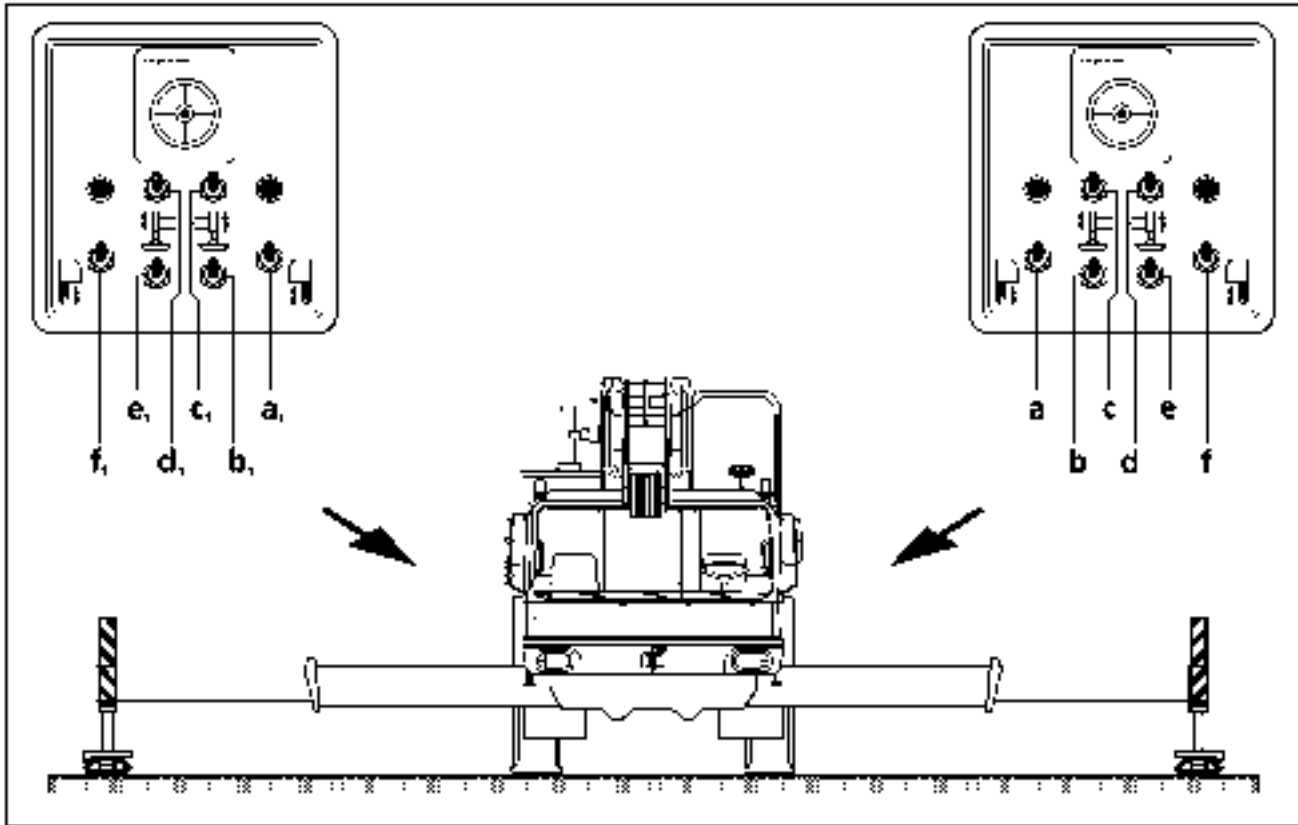

182956

Bring the outrigger pads from transporting to operating position

- Turn the pins (C) upward and pull them out.
- Pull the outrigger pads on the retainer handle to the stop (1.3) onto the ball head of the outrigger cylinder.
- Insert pin (C) into the bore hole (1.2) and turn the handle downward to secure it.

CAUTION: When the outrigger pad retainer is being pulled out, do not pull it to the end. Before reaching the end, apply manual counterpressure to prevent the outrigger pad from dropping downward!

- Loosen the mechanical lock, pin (B) on the four sliding arms and remove it.
- Open the control box for the outriggers, on the left or right side of the vehicle..

Control box functions on the left side of the vehicle

- | | | | |
|----|--------------------|-------------|------------------|
| a) | Sliding arm | left front | extend / retract |
| b) | Outrigger cylinder | left front | extend / retract |
| c) | Outrigger cylinder | right front | extend / retract |
| d) | Outrigger cylinder | right rear | extend / retract |
| e) | Outrigger cylinder | left rear | extend / retract |
| f) | Sliding arm | left rear | extend / retract |

Control box functions on the right side of the vehicle

- | | | | |
|------------------|--------------------|-------------|------------------|
| a ₁) | Sliding arm | right front | extend / retract |
| b ₁) | Outrigger cylinder | right front | extend / retract |
| c ₁) | Outrigger cylinder | left front | extend / retract |
| d ₁) | Outrigger cylinder | left rear | extend / retract |
| e ₁) | Outrigger cylinder | right rear | extend / retract |
| f ₁) | Sliding arm | right rear | extend / retract |

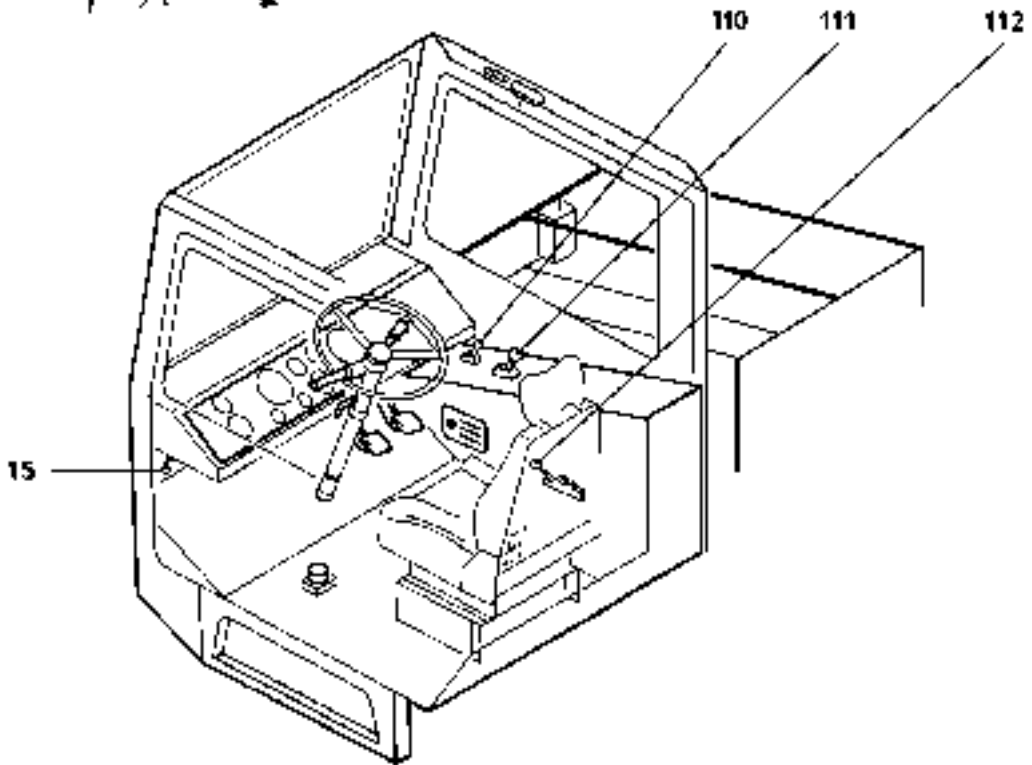
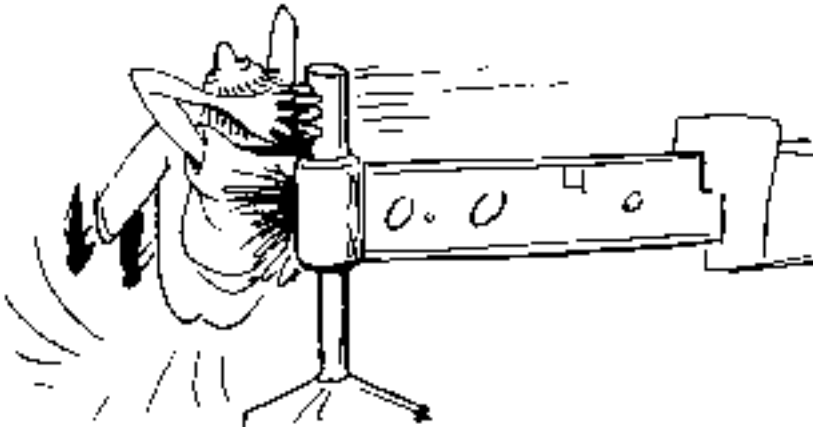
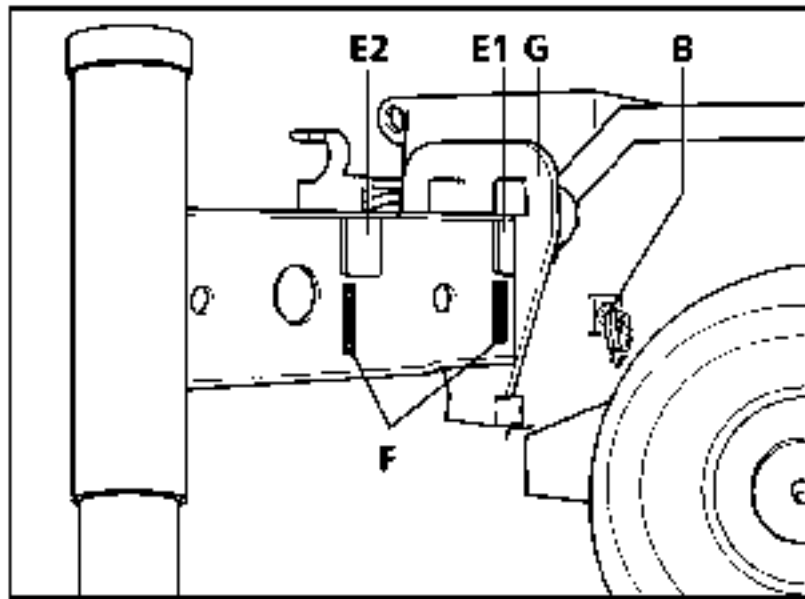

Support the crane

- Start the engine again.
- Raise the engine to ca. 1500 RPM with hand lever (112).

Extend sliding arms from the chassis

DANGER: The operator must carefully observe the sliding arms when extending and retracting.
Whenever extending or retracting the sliding arms, make sure there are no persons or objects in the danger zone.

- Extend the sliding arms to the support base specified in the load capacity table.
- Check agreement of area of ground contact (E1 or E2).

Note: E1 = wide support base
E2 = reduced support base

The markings (F), used by the crane operator to check extension/retraction, are located just before the edge of the outer part of the sliding arm (G) if it is correctly extended.

- Secure all 4 sliding arms with 1 pin each (B).

DANGER: The sliding arms must be secured with pins in order to prevent unintentional adjustment. If this is not done, there is the danger of accidents.
The pins (B) must be completely inserted with the hand grip pointing down, otherwise there is the risk of the crane toppling over!

Inspecting the supports

Note: All safety regulations and status of the extended sliding arms must be checked again. If this is not done, there is a risk of accidents.

DANGER: All 4 sliding arms must be extended, including those on the side opposite the load. If only the sliding arms on the load side are extended, this may have serious consequences because:

1. The load hanging on the hook tensions the hoist cable and the telescopic boom (and also the extension fly jib if used and guy ropes) and also deforms them.
If, in this situation, the load drops out of the lifting tackle cables, or if the lifting tackle cable or hoisting cable break, there is suddenly no load on the boom. It jerks up violently, which could cause the crane to topple over.
2. Despite what has been assumed before starting crane operation, it may prove necessary to slew the load to the opposite side. If this happens, the crane can topple over.
3. When slewing away from the vehicle's longitudinal axis, the boom and/or ballast torque may be sufficient to cause the crane to topple over.

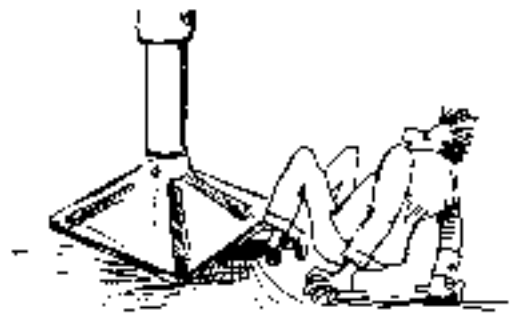
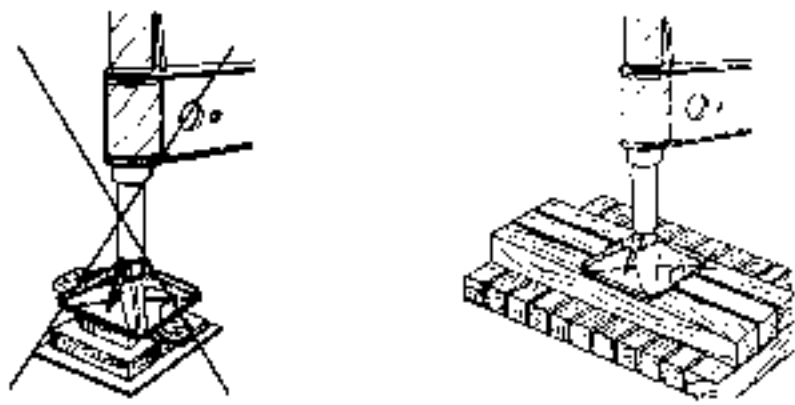
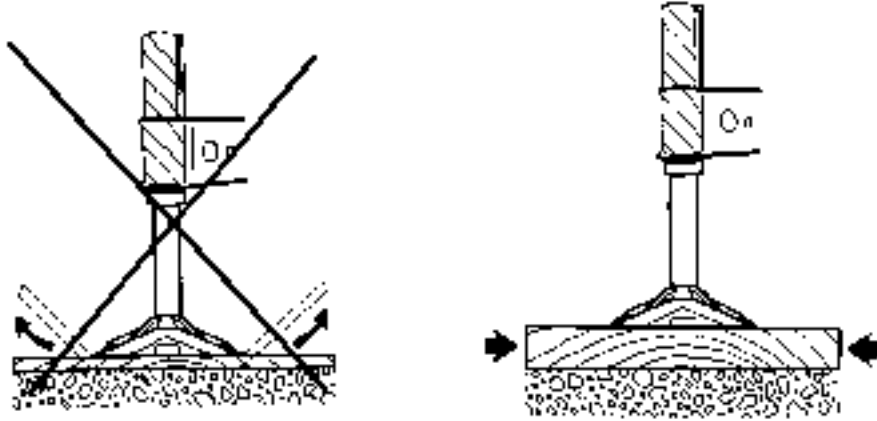

Supports

The support pads must be given a foundation, corresponding to the ground conditions, of a large surface area of stable materials, such as wood, steel or concrete slabs.

Note: Refer to the safety notes and permissible ground bearing load (Chap. 2.04).
Support pad area = 2500 cm²

DANGER: Only suitable materials may be used for making a foundation. The foundation must be placed in the middle beneath the support pads. If this is not done, there is a risk of accidents.

Extending/retracting the support jacks from the chassis

- From one of the switch boxes, extend the support jacks and raise the crane so that the wheels no longer contact the ground.

DANGER: If this not done, the axles may be damaged due to bending of the vehicle frame during crane operation.

When operating from the switch box, only those support jacks may be operated which can be directly observed by the operator.

Whenever extending or retracting the support jacks, make sure there are no persons or objects in the danger zone.

Aligning the crane horizontally

- Align the crane horizontally by extending and retracting the individual support jacks. This is achieved when the air bubbles of both mirror bubble gauges are in the innermost ring.

DANGER: If the crane is not horizontally aligned, there is increased risk of accident.

Note: Maximum permissible deviation from the horizontal is $\pm 0.5\%$ ($\pm 0.3^\circ$).
The air bubbles of the mirror bubble gauges must be in the innermost ring (center).
If the mirror bubble gauges become maladjusted as a result of external forces, they must be reset. To do so, first align the crane exactly horizontally in a longitudinal and lateral direction with reference to a spirit level placed on the slewing ring, or as near as possible to the slewing ring on the chassis. Then reset the mirror bubble gauges at the adjusting screws and secure them at the correct setting. The setting of the mirror bubble gauges will not alter during normal travel and crane operations.

- If the crane is aligned, move the engine regulator to idle speed and shut off the engine with the engine shut-off button.
- Switch off the ignition and remove the ignition key.

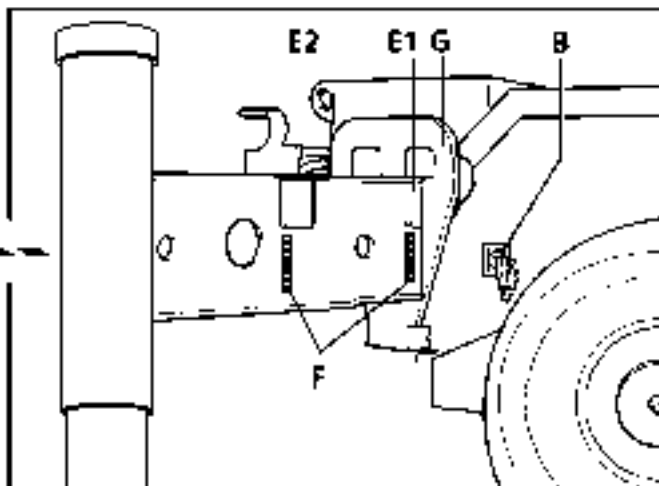
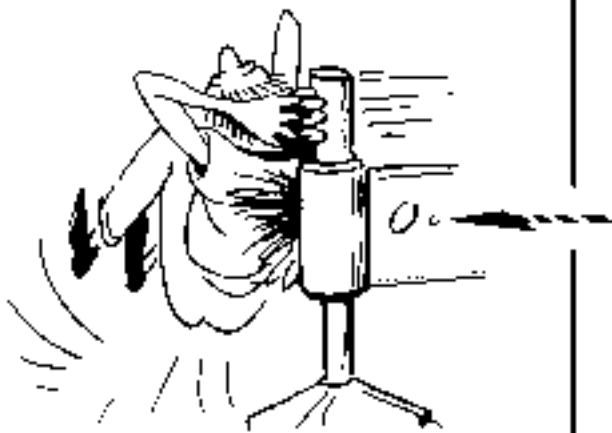
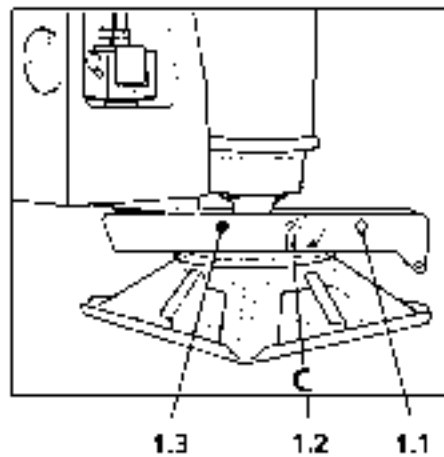
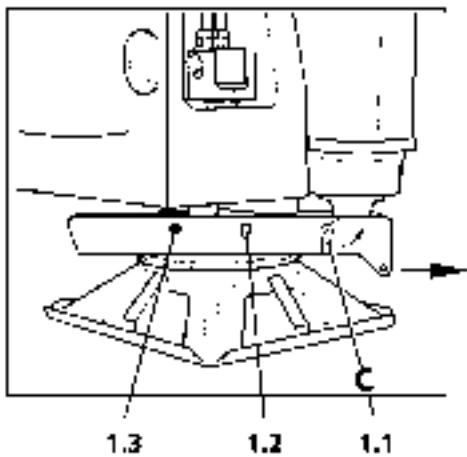
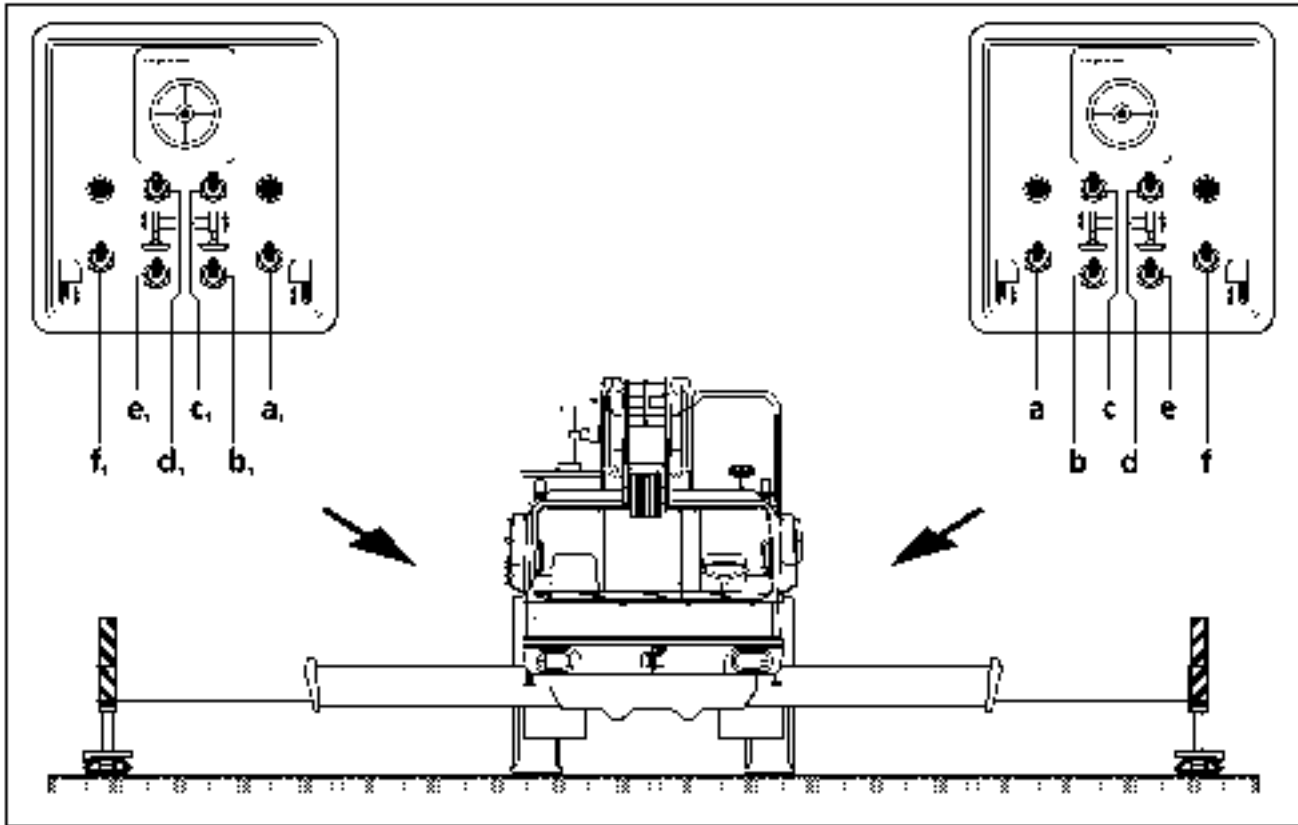

182956.

Retracting the sliding arms from the chassis

D A N G E R: **The operator must only operate those sliding arms which can be directly observed. Whenever extending or retracting the sliding arms, make sure there are no persons or objects in the danger zone.**

- Loosen the mechanical locking pins (B) on the four sliding arms and remove.
- Individually retract the sliding arms and secure with the four (B) pins.
- Move the engine regulator to idle speed and shut off the engine,
- Switch off ignition and remove the ignition key.

Bring the support pads from the operating into the transport position

- Turn pin (C) upward and pull it out.
- Push the support pad on the retainer handle all the way in to the stop.
- Insert pin (C) into the bore hole (1.1) and turn the handle downward to secure it.

C A U T I O N: **When pushing in, before reaching the end, counter pressure must be applied by hand in order to prevent the support pad from folding down!**

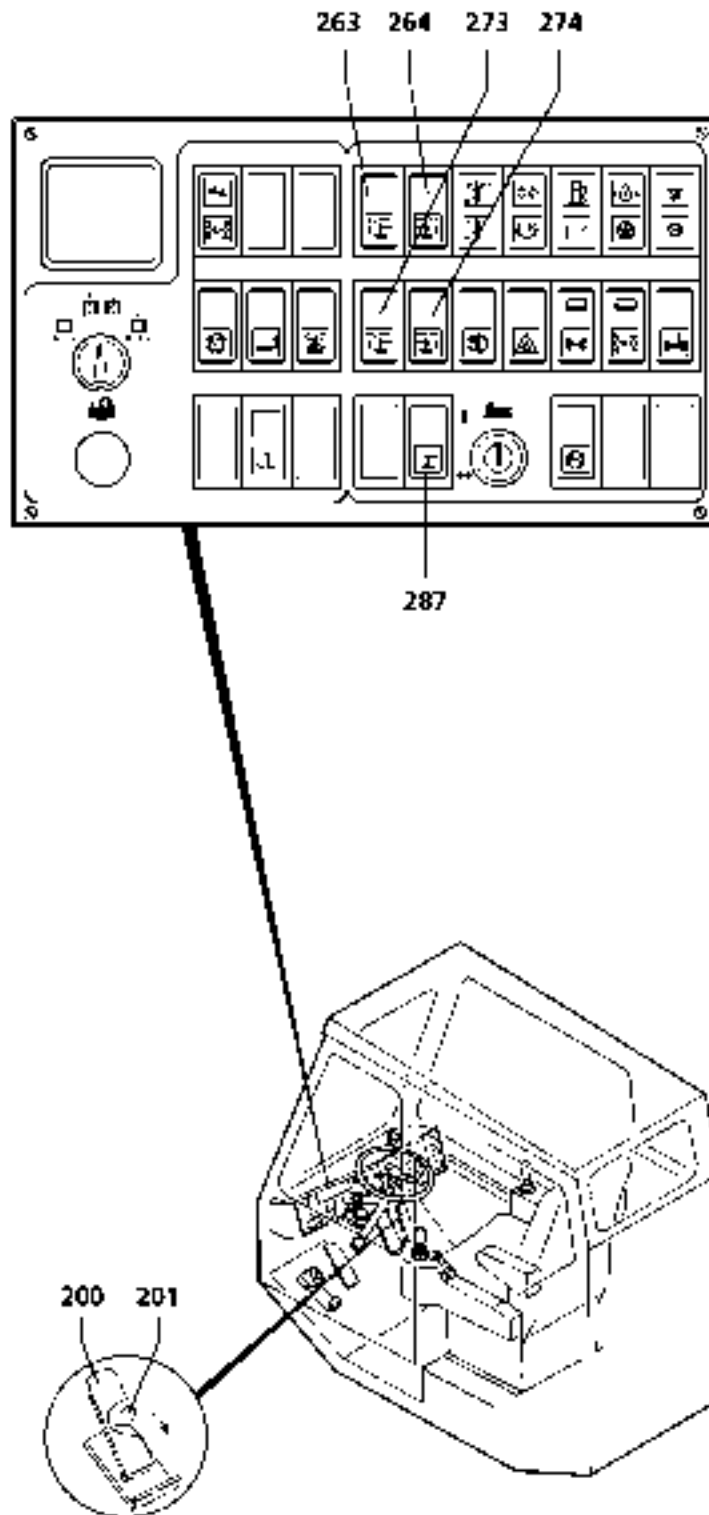

Supporting the crane from the crane operator's cab

CAUTION: All guidelines and danger warnings previously mentioned for supporting the crane from the chassis should be observed.

Requirements:

- the crane is on level, solid ground,
- the change-over switch (15) in the driver's cab is switched to position "superstructure",
- the axle suspension is locked, i.e. switch (97) in the driver's cab is switched on,
- the diesel engine is running.

Note:

During the crane supporting procedure, the idle speed of the diesel engine can be raised to approx. 1200 rpm.

To do this, move the lever (201) on the accelerator pedal (200) out of the ZERO position (upper right) down and to the right and depress the accelerator pedal briefly.

If the increased idle speed is no longer required, the lever (201) must be placed back in the ZERO position.

Supporting the crane

If the crane supporting procedure is to be carried out from the crane operator's cab, the movement desired (sliding arm or support cylinder) must be pre-selected with the pre-selection button (287).

The pre-selector button (287) **must always be held down** when one of the buttons (263, 264, 273 or 274) is pressed.

This safety circuit is built-in to prevent the crane from shifting into a dangerous uneven position if a support system button is accidentally pressed.

Before activating the support jacks, a warning signal must be given (horn).

Note:

Buttons (263, 264, 273, 274) each have four functions, corresponding to the four symbols.

DANGER:

The operator must observe the sliding arms being extended or retracted.

When extending or retracting the support system without visual contact with the relevant support cylinder or sliding arm, always work with a guide.

When extending or retracting the sliding arms, make sure that no persons or things are in the danger area. If the crane is not aligned horizontally, there is danger of accidents occurring.

All four sliding arms must be extended, i.e. those on the opposite side from the load as well.

Extending the sliding arms:

Hold button (287) pressed "**downwards**" and at the same time:

- Press button (263) "downwards" - Forward left sliding arm extends,
- Press button (264) "downwards" - Forward right sliding arm extends,
- Press button (273) "downwards" - Rear left sliding arm extends,
- Press button (274) "downwards" - Rear right sliding arm extends,

Extending the support cylinders:

Hold button (287) pressed "**upwards**" and at the same time:

- Press button (263) "downwards" - Forward left support cylinder extends,
- Press button (264) "downwards" - Forward right support cylinder extends,
- Press button (273) "downwards" - Rear left support cylinder extends,
- Press button (274) "downwards" - Rear right support cylinder extends.

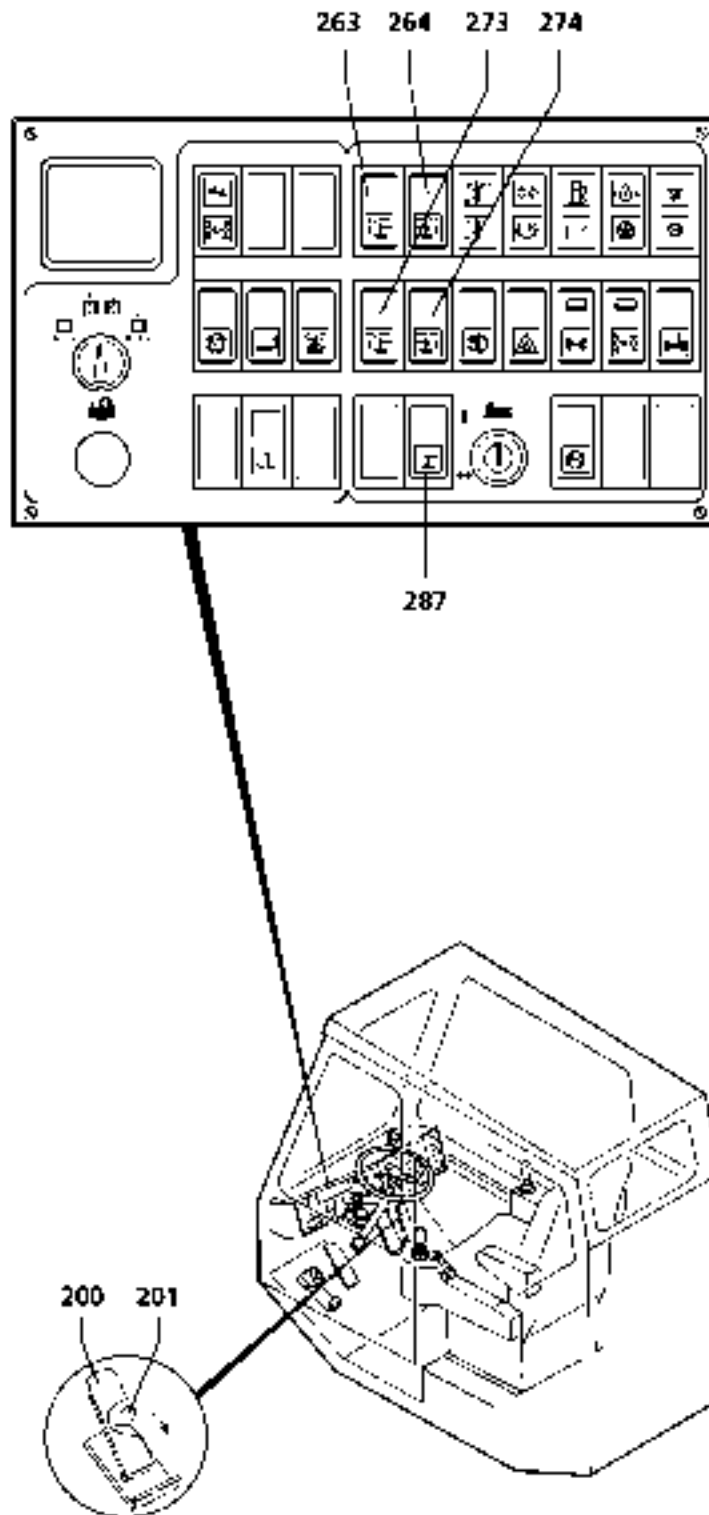

Retracting the sliding arms:

Hold button (287) pressed "**upwards**" and at the same time:

- Press button (263) "upwards" - Forward left sliding arm retracts,
- Press button (264) "upwards" - Forward right sliding arm retracts,
- Press button (273) "upwards" - Rear left sliding arm retracts,
- Press button (274) "upwards" - Rear right sliding arm retracts,

Retracting the support cylinders:

Hold button (287) pressed "**downwards**" and at the same time:

- Press button (263) "upwards" - Forward left support cylinder retracts,
- Press button (264) "upwards" - Forward right support cylinder retracts,
- Press button (273) "upwards" - Rear left support cylinder retracts,
- Press button (274) "upwards" - Rear right support cylinder retracts,

D A N G E R : **The operator must observe the sliding arms being extended or retracted.**
 When extending or retracting the support system without visual contact with the relevant support cylinder or sliding arm, always work with a guide.
 When extending or retracting the sliding arms, make sure that no persons or things are in the danger area. If the crane is not aligned horizontally, there is danger of accidents occurring.
 All four sliding arms must be extended, i.e. those on the opposite side from the load as well.

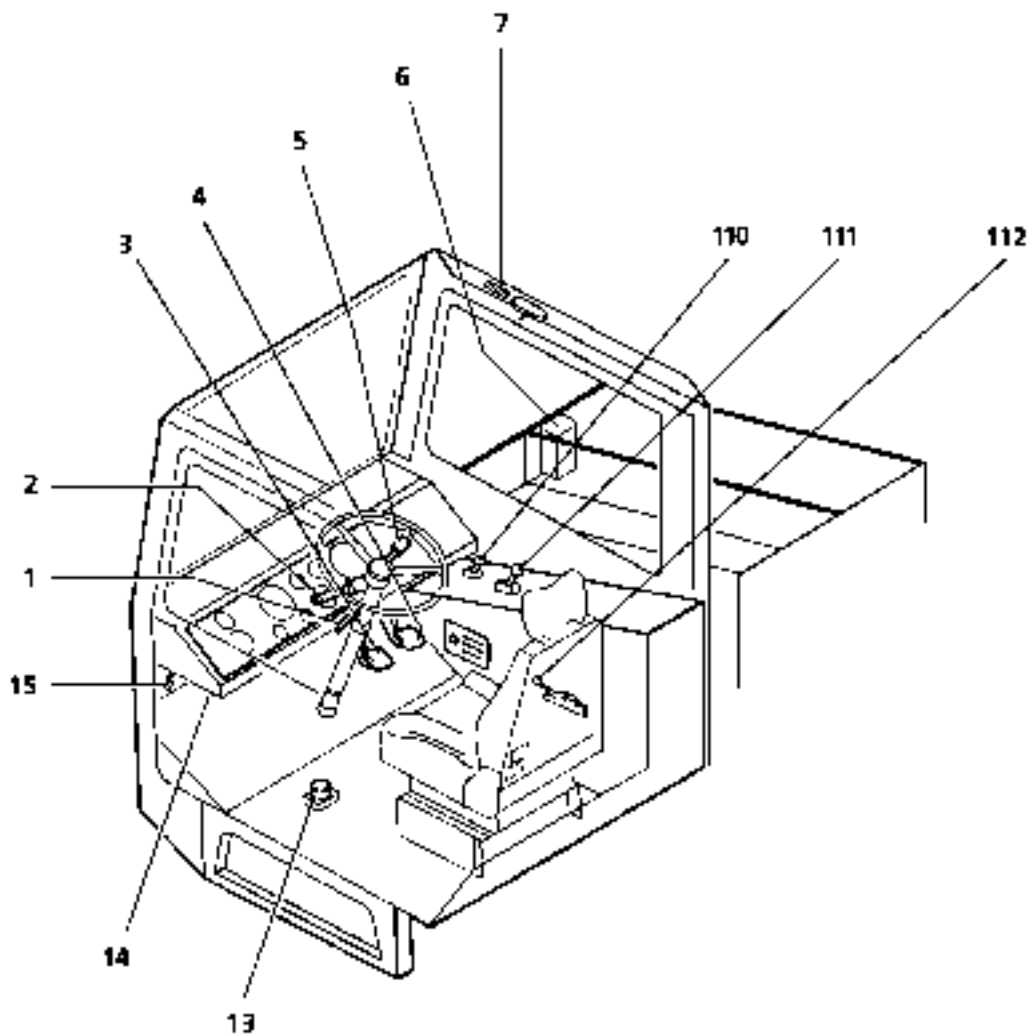
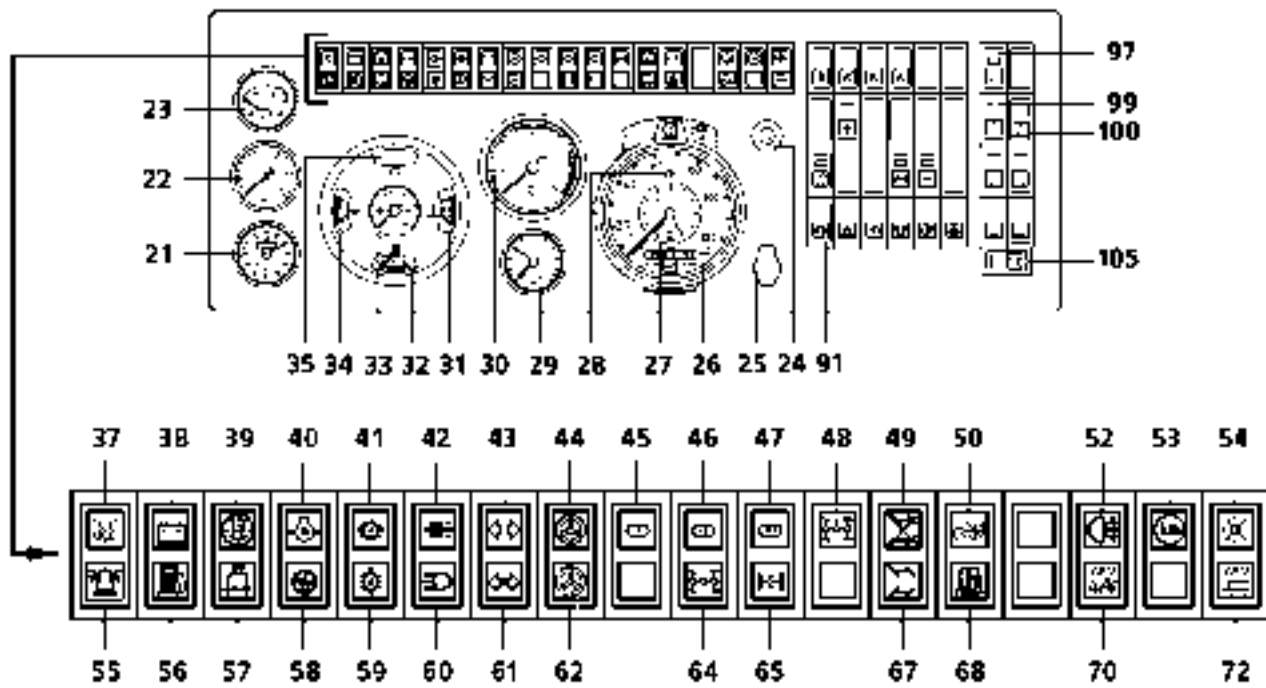

Switching from crane operation to driving**Requirements:**

- The axle suspension is locked, i.e. the change-over switch (15) in the driver's cab is switched in position "superstructure"
- switch (97) is switched on
- The manual brake lever is engaged in the driver's cab as well as in the crane cab.
- The gear selector (111) is in the neutral, position "N".
- The crane is supported.
- The crane is horizontally aligned by the support jacks on the support pads.
- There is no contact between the wheels and the ground.
- The telescoping parts are retracted and locked.
- The ballasts are distributed as in Chap. 3.04.
- The telescopic boom is forward and locked in the boom receiver.
- The hook block is secured as in Chap. 3.03.
- the engine is shut off,
- the ignition is switched off
- The ignition key is removed.
- The battery master switch is switched on.

Note: For driving and transporting, all the ballast and the hook block must be transported as in Chap. 3.04.

Changeover

- Switch on the ignition in the driver's cab.
- Switch the change-over switch (15) in the driver's cab in position "crane chassis", both axles are thus suspended.

Start the engine

- Raise the engine idle speed to approx. 1500 rpm using the hand lever (112),
- Open the switch box on the left or right.
- Retract the support jacks to the point where there is contact with the ground.
- Switch off switch (97).

CAUTION: Only switch off switch (97) once the wheels are in contact with the ground. If this is not done, the axle suspension will be damaged due to sudden release of the axle locking.

Retracting the support cylinders

- Completely retract all support jacks individually.

DANGER: When operating the switch box, only those support jacks may be operated which can be directly observed by the operator. Whenever extending or retracting the support jacks, make sure there are no persons or objects in the danger zone.

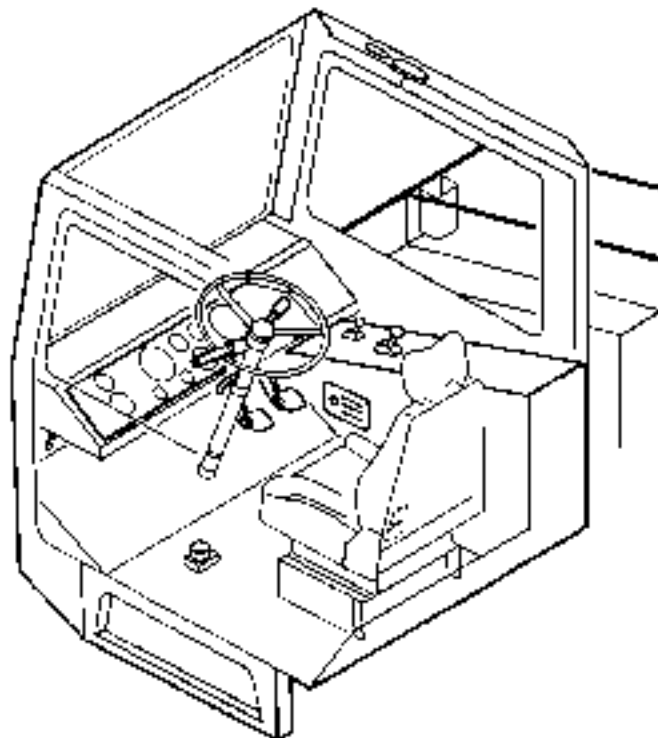
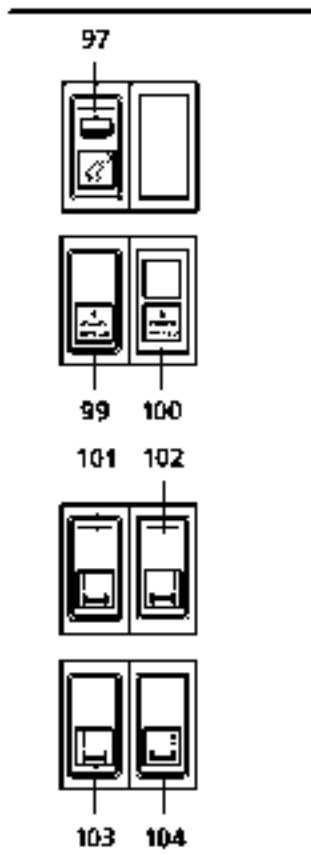
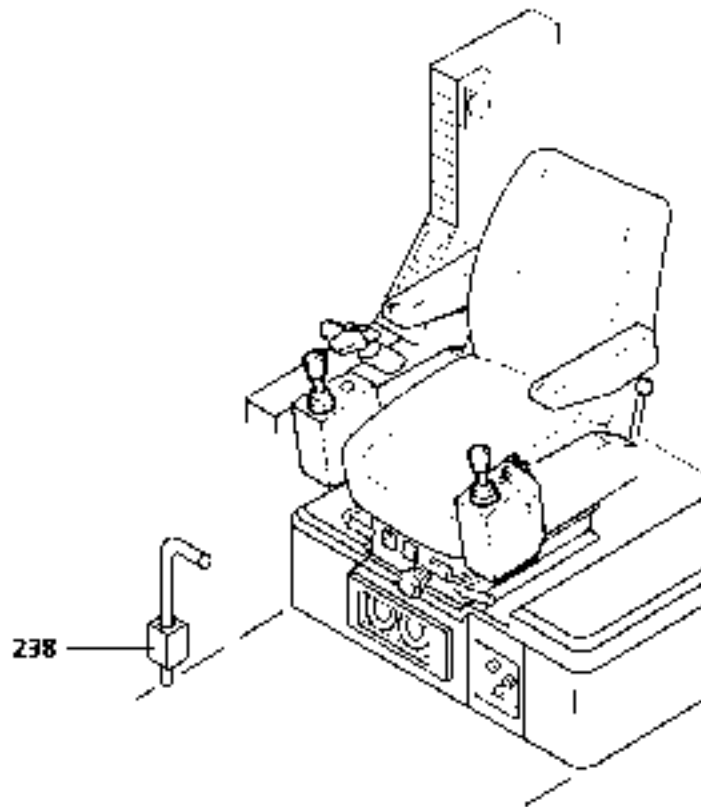
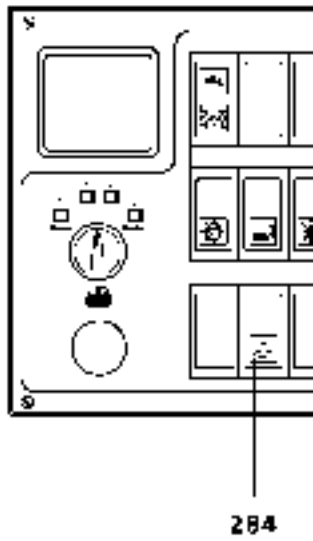

The following safety measure are to be checked and carried out before leaving the operating site:

- Is the rear axle steering locked in the "straight" position?
- Is the switch (97) for axle suspension "**locked**" switched off?
- Are the support jacks completely retracted?
- Are the sliding arms completely retracted?
- Are the sliding arms secured with pins?
- Are the pins safely inserted with the grip pointing down?
- Are the pins in their holders and secured so that they cannot fall out?
- Are the support pads secured so that they cannot fall out?
- Are the cowlings of the engine and converter fastened securely?
- Is the assembly cover for installing and removing the transfer case firmly in place ?
- Are the panels of the slewing platform closed and locked?
- Are the doors and windows of the crane cab closed and locked?
- Are the wheel chocks in their holders and secured from falling out?
- Is the telescopic boom completely retracted, locked, and in its receiver?
- Are the switch boxes on both sides closed and locked?
- Is the spare tire correctly mounted and secured with a spring keeper?
- Is the hoisting cable (with the hook block) fastened to the tow coupling bolts and secured against accidentally falling off?

D A N G E R : **All locks, spring keepers, and safety pins must be mounted and secured so that they are not able to loosen by themselves, fall out, and thus cause damage. Non-adherence to the safety measures, securing measures and other controls increases the risk of accidents.**

Note: After long periods of operation at an operating site, all procedures, prechecks and controls described Chap. 3.02, "**BEFORE STARTING**" must be carried out before driving away.

Chapter 4

Operation of the Superstructure

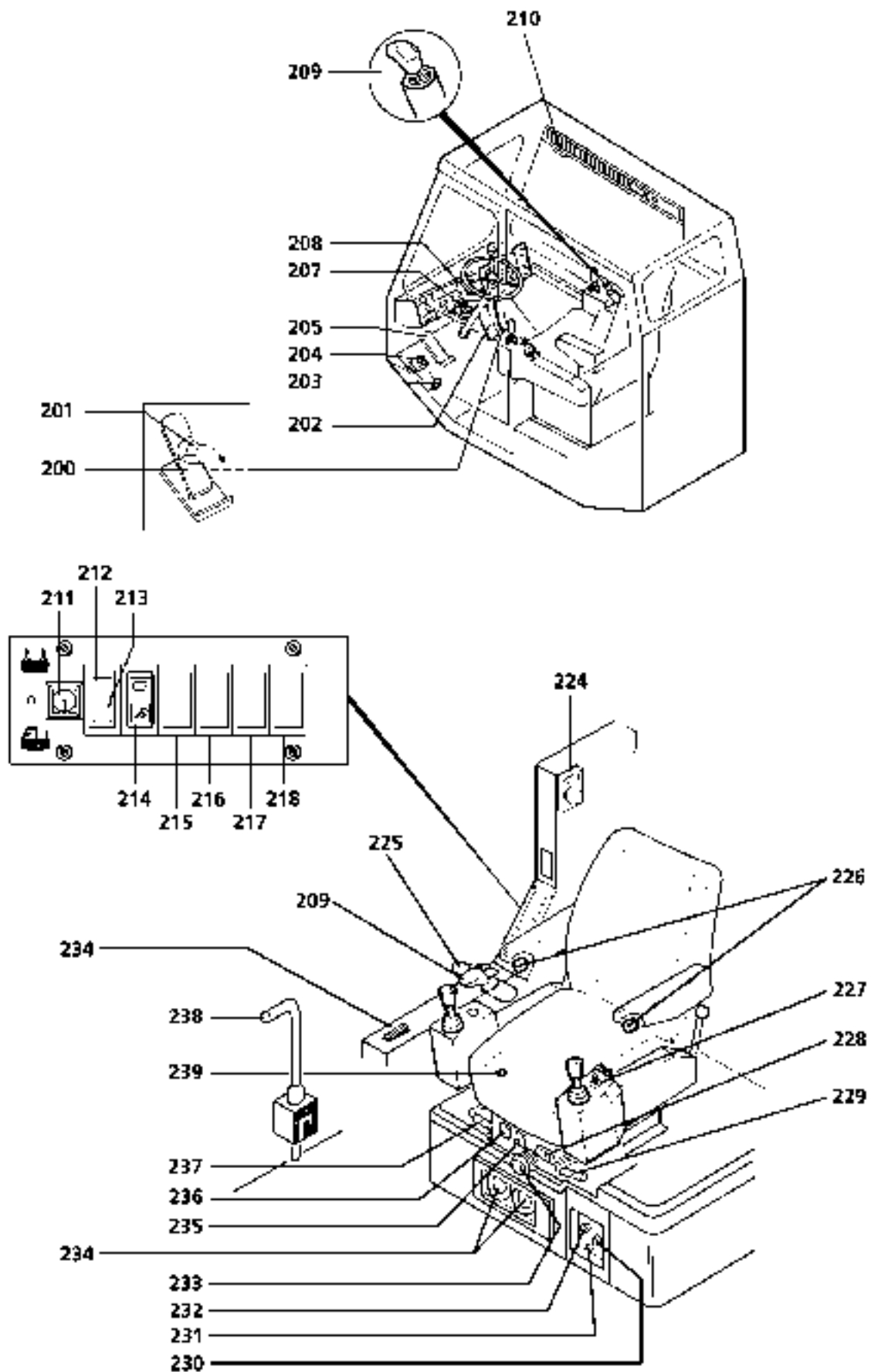

Item:

200	Foot pedal	- Driving engine and crane engine regulator
201	Lever	- Engine regulator lock (for raising engine speed)
202	Foot pedal	- service brake
203	Foot pedal	- "Control enable", bypass for seat contact switch
204	Foot pedal	- Acoustic horn
205	Foot pedal	- Slewing gear brake
206	reserved	
207	Bubble gauge	- Monitoring of crane horizontal alignment
208	Switch	- flashing turn indicators
209	Turning handle	- Gear selector
210	Roof light with switch	
211	* Key-operated switch	- Working platform
212	* Indicator lamp	- (green) comes on if key-operated switch (211) is switched to "working platform"
213	* Indicator lamp	- (red) comes on if key-operated switch (211) is switched to "emergency operation crane's cab"
214	Switch	- Operations spot light
215	* Switch	- Operations spot light, roof or boom head
216	reserved	
217	reserved	
218	reserved	
219	reserved	
220	reserved	
221	reserved	
222	reserved	
223	reserved	
224	Control unit with thermostat for L. P. G. heater	
225	Manual lever	- Hand brake (parking brake)
226	Rotary knob	- Adjustment of arm rest angle
227	* Button	- Rear axle steering
228	Manual lever	- Adjustment of seat back
229	Manual lever	- Release for horizontal seat adjustment
230	Rotary switch	- 3-stage blower
231	Rotary controller	- Cab heating temperature
232	Slide controller	- Crossover switch, fresh / recirculated air, air amount
233	Rotary handle	- Adjusting seat height (adjust rotary handle to driver's weight)
234	Air outflow	- Crossover switch, air flow up / down
235	Button	- Lower back support in upper seat back
236	Button	- Lower back support in lower seat back
237	Manual lever	- Seat angle adjustment
238	Manual lever	- mechanical slewing platform locking
239	Seat contact switch	

* Optional

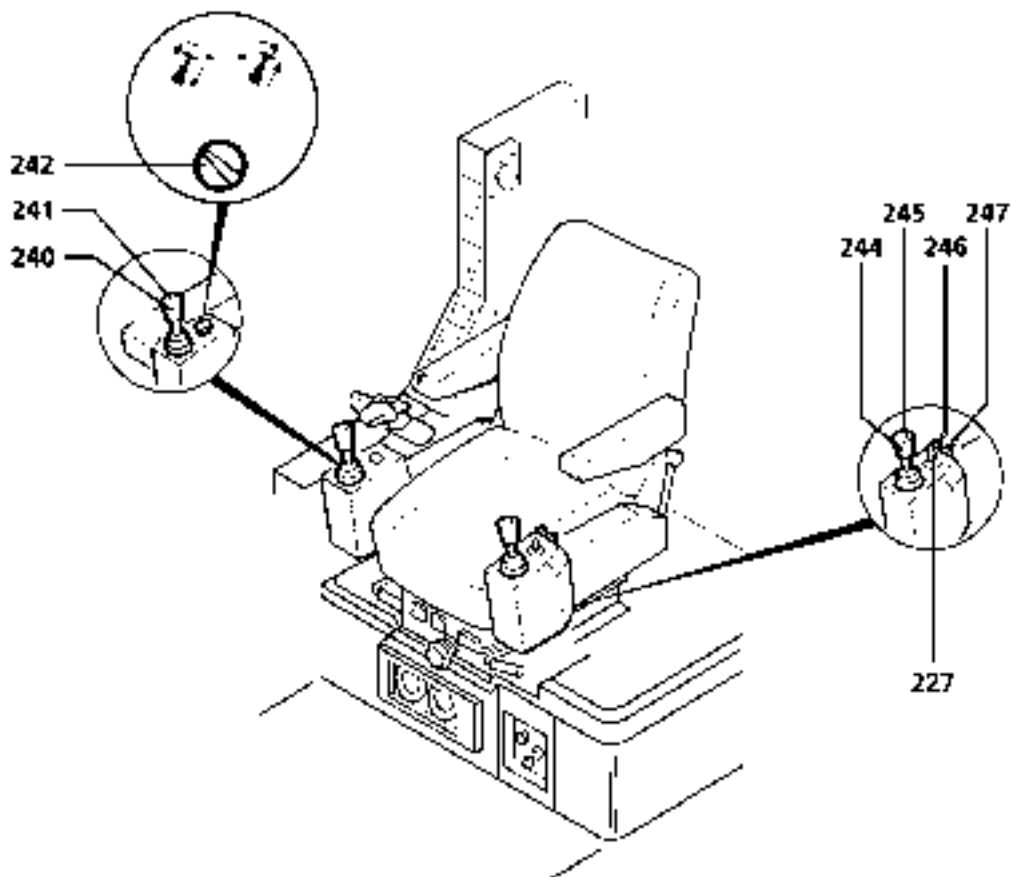
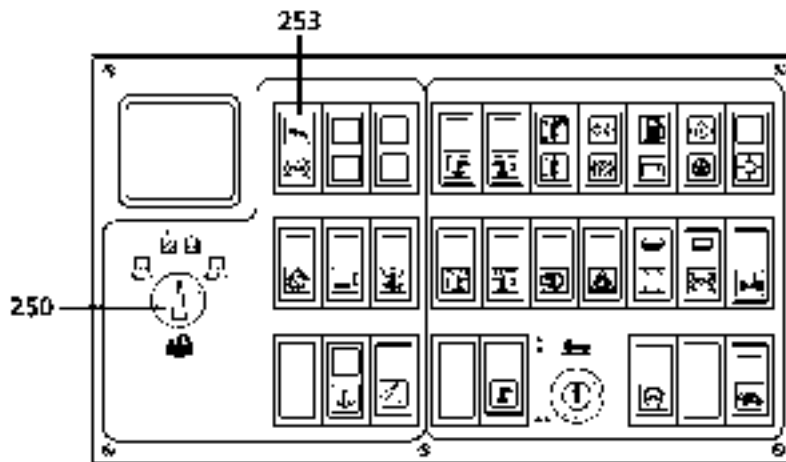

Item:**Versions with one hoisting gear**

240	Manual control lever	- Hoisting gear and luffing gear
241	Button	- Switches on fast gear for hoisting gear / luffing gear / telescoping gear
242	Reserved	
243	Reserved	
244	Manual control lever	- Slewing gear and telescoping gear
245	Button	- no function
246	Button	- By-passes LICCON overload safety device, for topping boom under overload
247	Switch	- Slewing gear brake "open/close"
248	Reserved	
249	Reserved	
250	Reserved	

Versions with 2 hoisting gears *

240	Hand control lever	- Hoisting gear I and luffing gear or telescoping gear, depending on position of switch (242)
241	Button	- Switches on fast gear for hoisting gear I + II, luffing gear and telescoping gear
242	Rotary switch	- Preselecting crane movements "telescoping" or "luffing the boom" Setting to the LEFT: LUFFING Setting to the RIGHT: TELESCOPING
243	Reserved	
244	Manual control lever	- Slewing gear and hoisting gear II
245	Button	- no function
246	Button	- By-passes LICCON overload safety device, for topping boom under overload
247	Switch	- Slewing gear brake "open/close"
248	Reserved	
249	Reserved	
250	Reserved	

* Optional

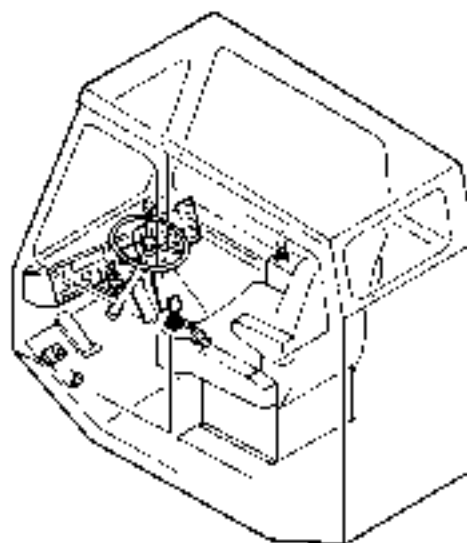
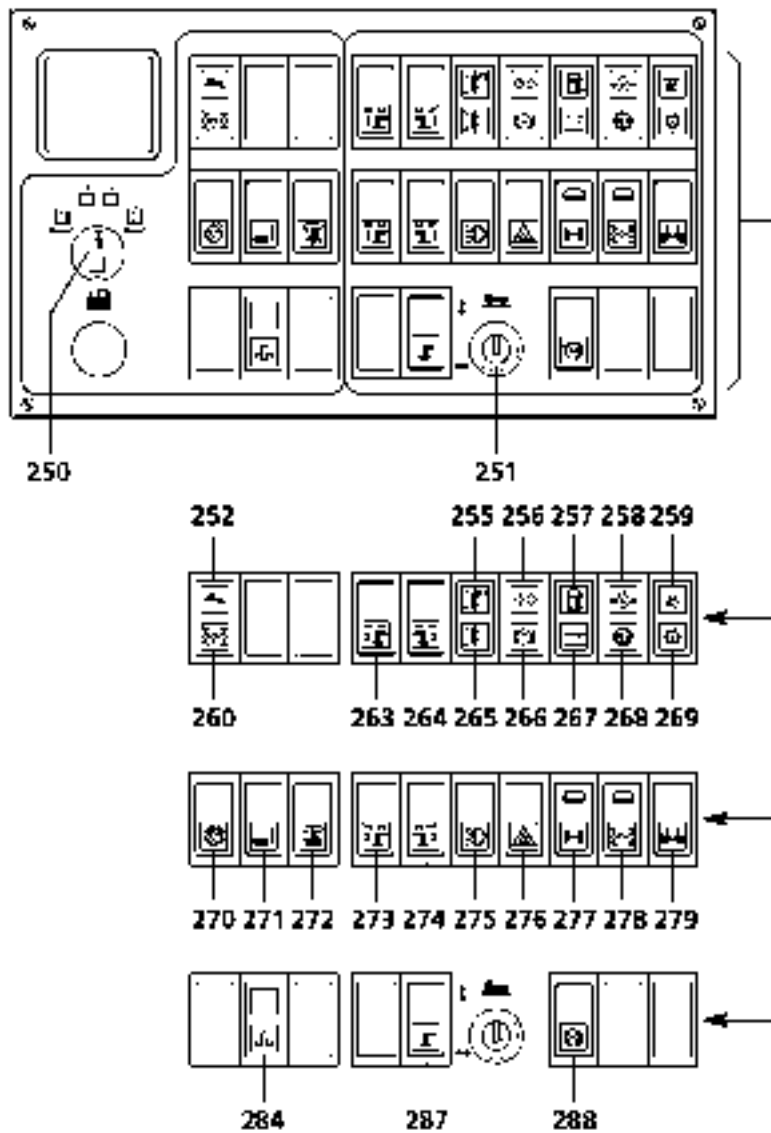

Item:

251	Ignition/Start key	- activated switch drive engine and crane engine
252	Control lamp	- fast gear engaged
253	Reserved	
254	Reserved	
255	Control lamp	- forward positioning of slewing platform
256	Control lamp	- driving direction indicator
257	Warning lamp	- Driving and crane engine fuel level
258	Warning lamp	- Oil pressure in driving and crane engine
259	Blinking light	- Preheating engine
260	Indicator light	- Crane hydraulic system switched on
261	Reserved	
262	Reserved	
263	Button	- Extend/retract forward left sliding arm or support cylinder
264	Button	- Extend/retract forward right sliding arm or support cylinder
265	Control lamp	- rear positioning of slewing platform
266	Control lamp	- parking brake set
267	Warning lamp	- Driving and crane engine generator
268	Warning lamp	- Driving and crane engine coolant overheated
269	Warning lamp	- Oil pressure too low or oil temperature too high in torque converter / on-load shift gearbox oil circulation
270	Switch	- control panel illumination
271	Button	- take on/jettison ballast
272	Button	- lock/unlock ballast
273	Button	- Extend/retract rear left sliding arm or support cylinder
274	Button	- Extend/retract rear right sliding arm or support cylinder
275	Switch	- low beam light
276	Switch	- hazard blinkers
277	Switch	- unlocking of rear axle steering
278	Switch	- All-wheel drive (switch front axle drive on / off)
279	* Button	- Front axle swinging
280	Reserved	
281	Reserved	
282	Reserved	
283	Reserved	
284	* Indicator light	- Slewing platform lock
285	Reserved	
286	Reserved	
287	Button	- Pre-selector support cylinder or sliding arm extend / retract
288	Button	- Driving and crane engine shut-off
289	Reserved	

* Optional

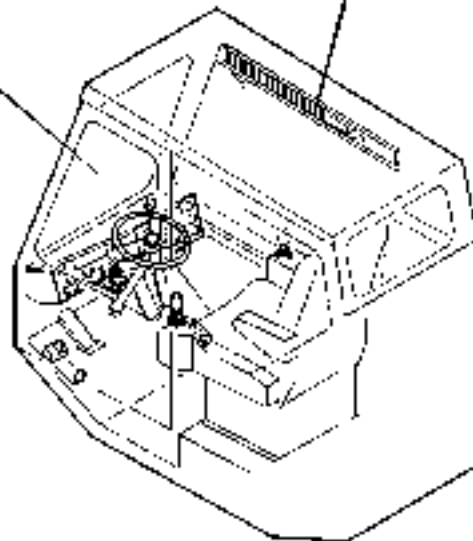
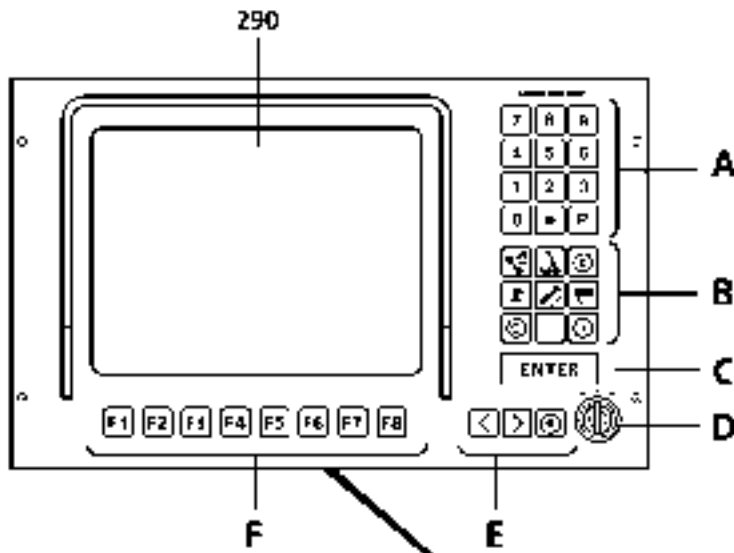
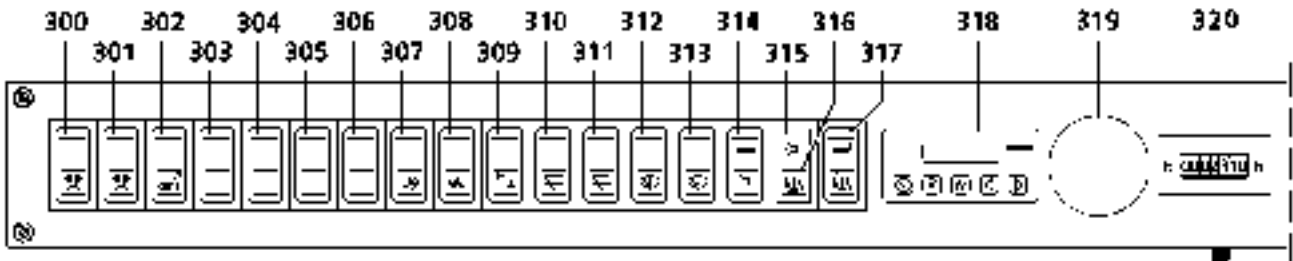

Item:

290 Operating and display element of the LICCON overload safety device
(see separate detailed operating instructions)

- A – Alphanumeric keypad
- B – Program keys
- C – Input confirmation key
- D – Assembly key-operated switch
- E – Scroll forwards/backwards
- F – Function keys

300	*	Switch	- Beacons
301	*	Switch	- Beacons
302	*	Switch	- Seat heater
303		Reserved	
304		Reserved	
305		Reserved	
306		Reserved	
307		Reserved	
308		Reserved	
309		Switch	- Hoist gear lighting
310	*	Switch	- Windshield washer - roof window
311		Switch	- Windshield wipers - roof window, 2 stage 1st stage interval, 2nd stage continuous
312	*	Switch	- Windshield washer - front window
313		Switch	- Windshield wipers, front window, 2 stage 1st stage interval, 2nd stage continuous
314	*	Switch	- Air conditioner system
315	*	Indicator light	- Air conditioner system
316	*	Indicator light	- Added heater
317	*	Switch	- Added heater
318	*	Digital clock	- with the following indicators: Time of day and day of the week, Problems in added heater system, Air temperature, Preselection of heating operation for added heater with 3 preselection times, each one can be preprogrammed up to 7 days in advance.
319		Reserved	
320		Indicator	- Hour meter - crane engine

* Optional

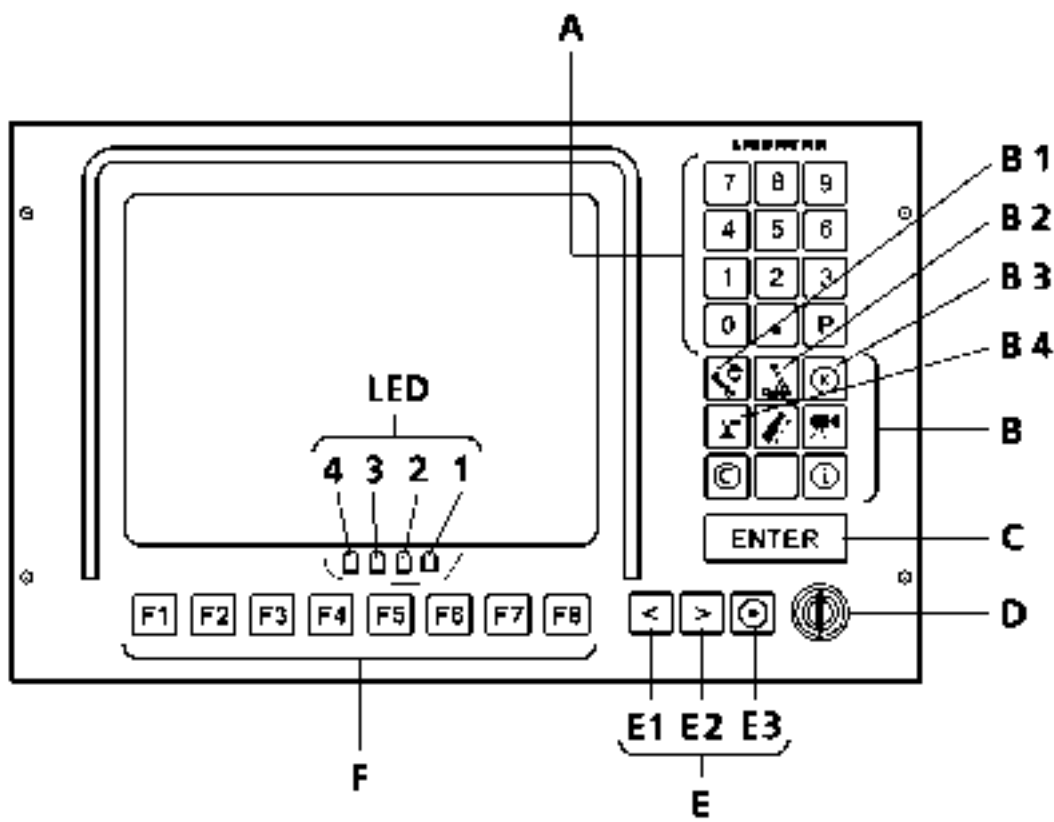

Operation:

See separately issued Operating Manual.

The LICCON overload safety device can be operated with the following control elements:

A - Alpha numerical keyboard

With the alpha numerical keyboard (A), numerical values can be entered and a coded equipment configuration view (load capacity chart) can be recalled on the screen.

The equipment configuration views are marked with a two digit number code.

If the entered code is confirmed with the button (C) ENTER, then the equipment configuration view (load capacity chart) appears on the monitor.

If the equipment configuration view is confirmed with button (F8) O.K., then it is taken on by the LICCON overload safety device and transferred to the "OPERATION" program. The operating view appears on the monitor .

B - Program keys

With the program keys (B), various LICCON programs can be recalled.

By pushing program key (B1), for example, the equipment configuration view can be called up, and with program key (B2), the operating view can be chosen.

During crane operation, various programs can be called up on the screen.

However, the crane operator is also able to view different equipment configurations, but he may **not** confirm them with the key (F8) O.K.

By pushing the program key (B2), the operating view returns to the view, with which the crane works.

The equipment configuration view may only be selected if no crane movements are initiated.

F - Function keys

With the function keys, operating conditions and functions, which are visible in the lower part of the screen as symbols, can be changed.

The function keys (F1 to F8) are always to be viewed in connection with the symbols above, since they have different meanings in different LICCON programs.

C - The (C) ENTER key is an input confirmation key.

If there is a function in the operating mode and / or the equipment configuration is being changed, than this change can only be confirmed with the key (C) ENTER and the load capacity chart can be called up on the screen.

If the change in operating mode and / or the equipment configuration is confirmed with the key (C) ENTER and an acoustical signal sounds, then the change **has not been accepted**. This means that the chosen operating mode or the chosen equipment configuration has not been programmed into the system.

D - The installation key (D) is used to bypass either the LICCON overload safety device or the hoist top limit switch.

On some cranes, the functions of this switch have been replaced by a switch on the instrument panel.

E - The keys (E1) and (E2) < > are used for horizontal paging and are needed when a load capacity chart is too wide to be viewed on one screen .

If keys (E1) and (E3) are pushed at the same time, the screen changes from light to dark.

When keys (E2) and (E3) are pushed at the same time, you can choose between 4 light levels.

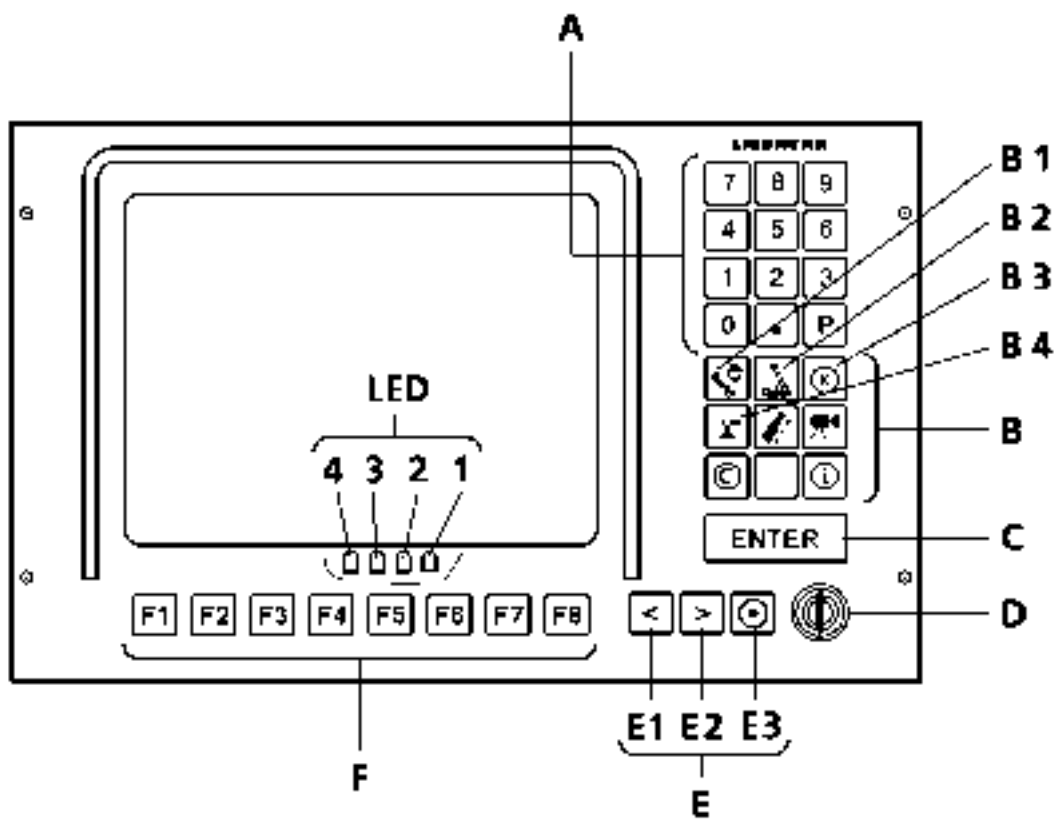

Description

The LICCON safe load indicator or overload safety device (Liebherr Computed Controlling) consists of an electronic module with power pack and micro processor central unit, the monitor with controls, pressure sensors, incline angle and length sensors.

As an overload safety device, the LICCON works according to the principle of a comparison of "should be" and "actual" values.

The "actual" values coming from length, angle and pressure sensors are compared with the "should be" values, which are stored in the central data processor, and then are calculated by the microprocessor.

The crane data values, such as the load capacity charts, boom weights, center of gravity and measurements, have been stored on data chips in the central data bank. This data is the reference information used to calculate any overload conditions.

The system functions are either controlled by automatic components such as boom length and angle sensors or by direct input into the dialogue functions on the monitor .

The prewarning symbol blinks when the load on the crane is 90 % or higher than the maximum load carrying capacity.

If the overload safety device recognizes a sensor problem, for example, which could lead to a dangerous situation, then it shuts down and displays a STOP symbol, even though the maximum permissible load carrying capacity has not been exceeded. The STOP symbol remains on and blinks as soon as the load on the crane exceeds the maximum permissible load carrying capacity.

An acoustical signal sounds with the blinking prewarning and STOP symbol.

If the crane shuts off due to overload, movements must be carried out which will reduce the load momentum, such as:

- setting the load down
- retracting the telescope
- luffing up while pushing the button "Luffing up at overload"

Load momentum increasing movements are:

- luffing down
- telescoping out
- taking on a load by luffing up.

The central unit recognizes ground problems, broken lines and short circuits after (+).

When the hoist top limit switch is triggered, the overload safety device is also triggered.

The movement "hoist gear up" and all load momentum increasing movements are shut off, the warning symbol hoist limit switch and the STOP symbol appear and blink on the monitor.

DANGER: The proper function of the load moment limiter is only assured if the adjusted operating mode, the equipment configuration and the hoist cable reeving actually match the condition of the crane.

If this is not observed, it can cause a serious accident!

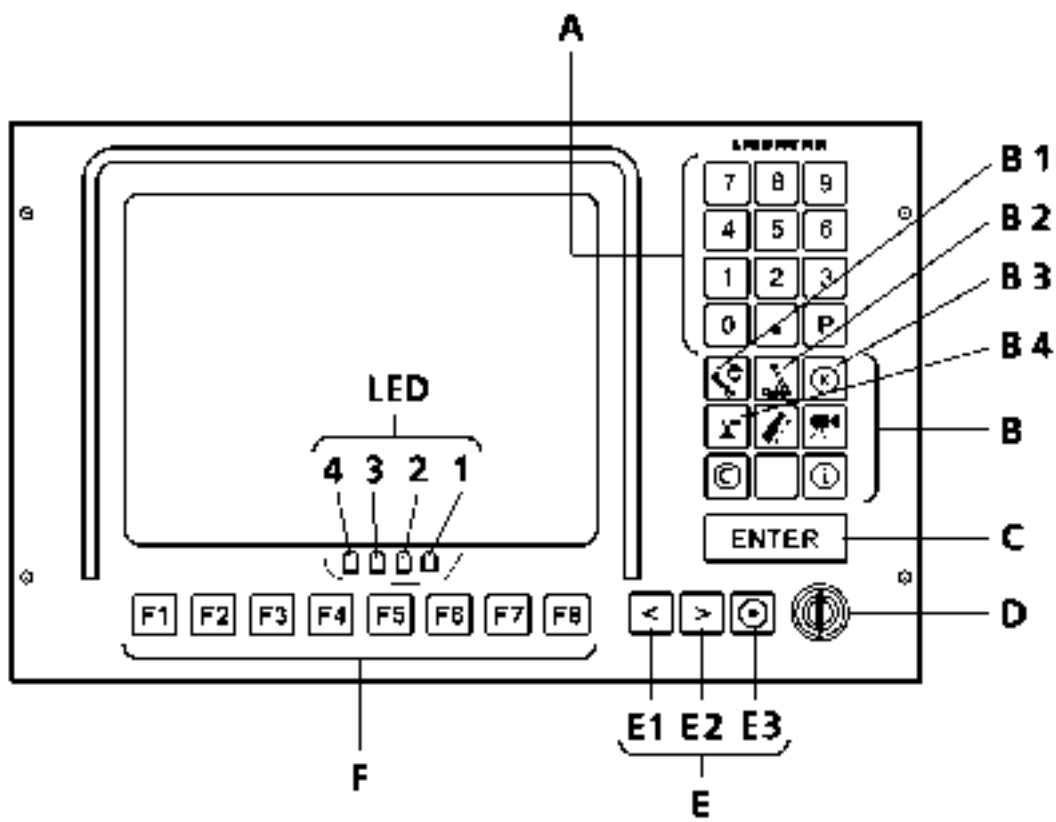

To weigh a load

The overload safety device makes it possible to determine the weight of a raised load (net load). This calculation, however, is only permitted if the approximate weight of the load is known and it can be assured that the crane is not overload.

With a free hanging hook block (with tackle), press the Tare button (F7) in the operating view. The "actual load capacity" is automatically reset to zero.

In the "actual load carrying capacity indicator symbol", the NET description will appear in addition.

If the load is now being raised via the hoist gear, then the net weight of the load will be indicated.

If the working radius is being changed, the indicator returns to indicate the gross weight.

Functions check for control and indicator unit

The status of the monitor and the controller is shown via four luminous diodes, which are located on the front behind the front windshield.

LED 1 (yellow)	24 V power supply available
LED 2 (red)	Error in controller (watchdog error)
LED 3 (green)	Self test of controller (Self test o.k.)
LED 4 (yellow)	Power supply for controller available

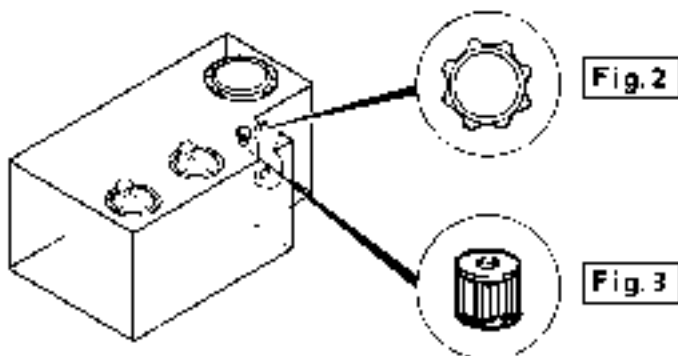
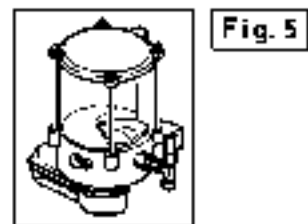
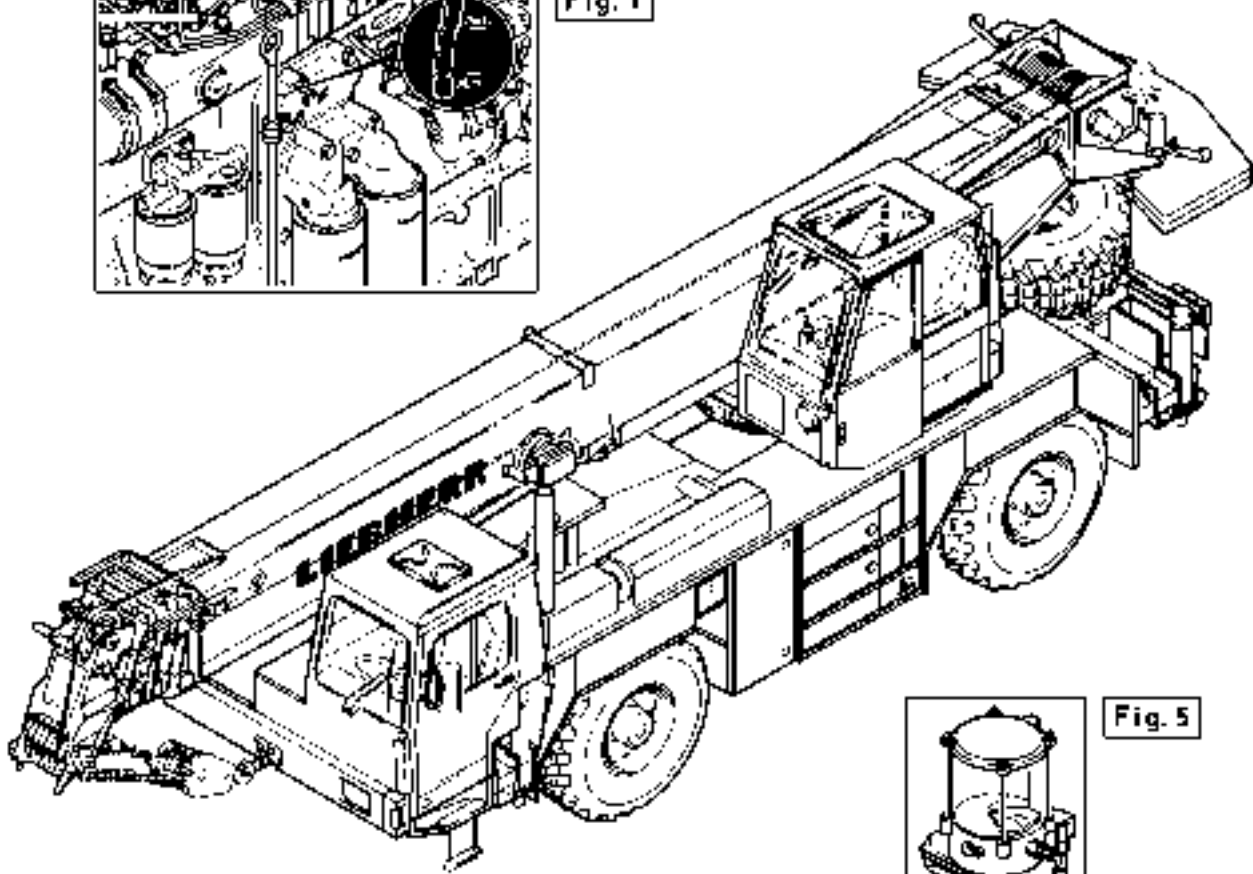
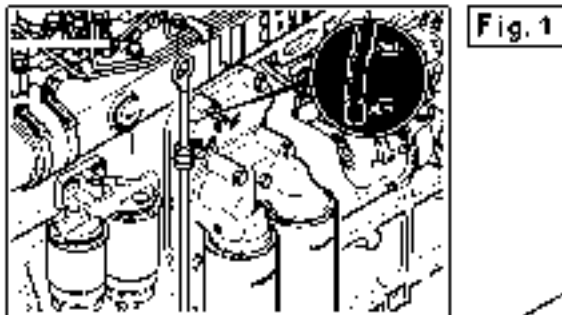
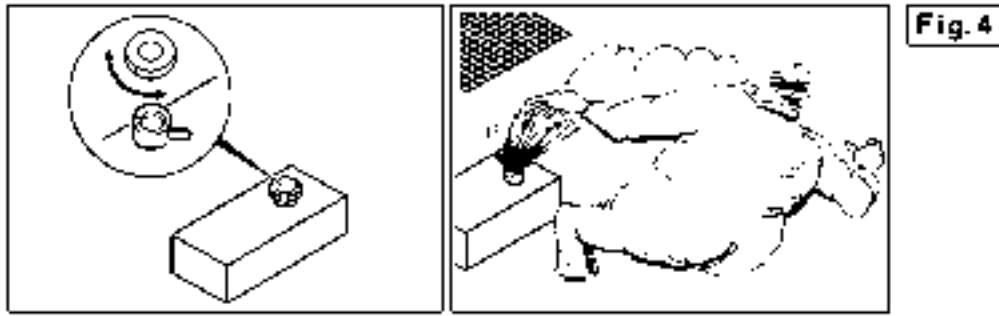

Prechecks before starting up

Before moving off, the following prechecks must be carried out:

Note: For a more detailed description of the following prechecks, see Chapter 7.05, "NOTES ON MAINTENANCE SUPERSTRUCTURE".

Check the filter and oil level

Oil level of the crane engine (Fig. 1)

- The oil level must be between the mini and maxi mark on the dipstick.

Oil level of the hydraulic tank for the crane hydraulics (Fig. 2)

- One of the two filters is fitted with a maintenance indicator.

Filter on the hydraulic tank (Fig. 3)

- Open the cover with the turn lock and visually check the filter for contamination.

Check the fuel level

Check fuel reserve at tank level gauge in the crane cabin and in the fuel tank.

Check the coolant level (Fig. 4)

The coolant must be filled to the rim on the filling nozzles.

DANGER: NEVER check the coolant level if the engine is still warm.
To check it, the engine must be cold, otherwise there is the danger of serious skin burns.

Central lubrication system (Fig. 5)

Make sure that the grease container is always filled with the specified grease, as noted on the lubrication chart.

Check the general condition and status of the crane

Before starting up the crane, the operator must ensure that the following conditions are fulfilled:

- The crane is properly supported and horizontally aligned.
- The toothed gear of the slewing ring must be clean and greased.
- Air inlets in oil radiator * and coolant radiator must be unobstructed.
- All cowlings and covers on the sides must be closed and locked.
- There are no persons or objects within the slewing range of the crane.
- Cable spool and rope spool as well as the limit switch must be free of snow and ice.
- There must be no loose objects on the slewing platform or on the telescopic boom.

DANGER: Before operating the boom in any way, it must be ensured that there are no loose objects resting on it, such as pins, spring keepers or ice.
If this is not ensured, there is a danger of accidents due to objects falling off and striking persons on the ground.

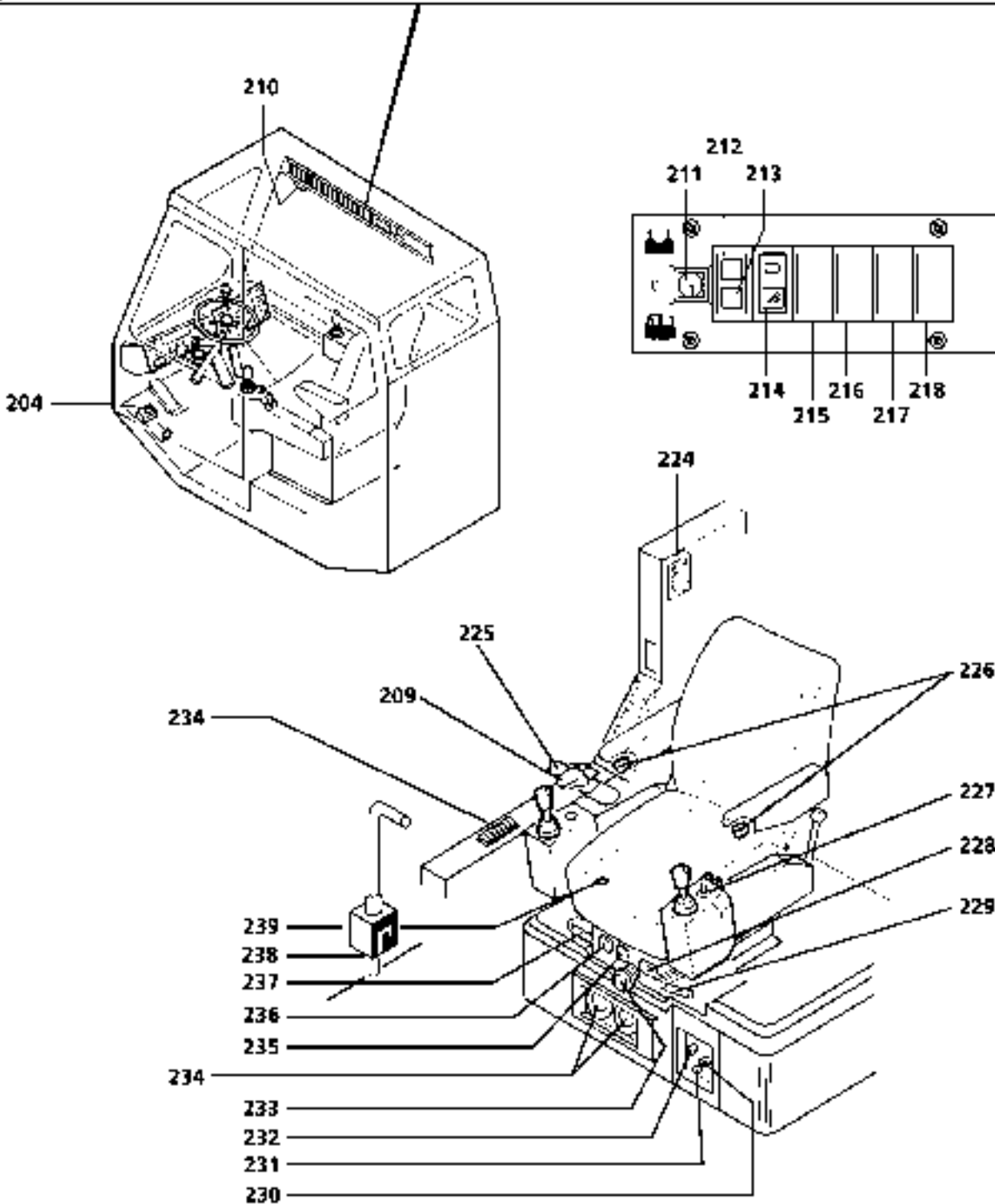
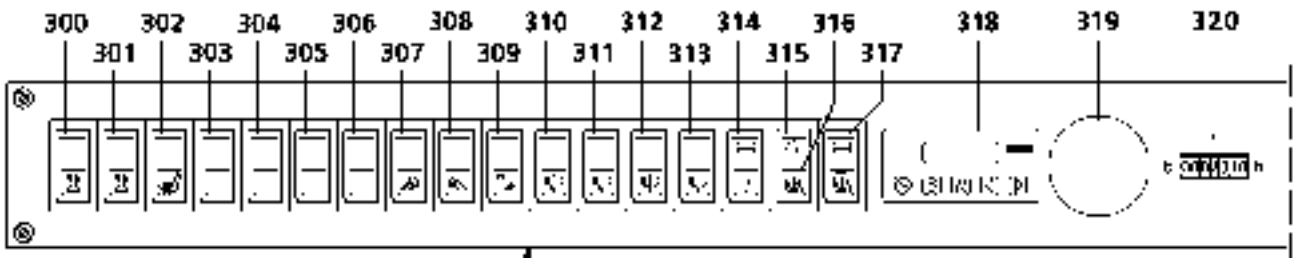

Adjust the seat/lock the arm rest

The hydraulically suspended driver's seat may be adjusted to any body size and weight.

- Adjustment of the arm rest angle (226)
- Adjustment of the seat angle (237)
- Adjustment of the seat back angle (228)
- Release for horizontal seat adjustment (229)
- Adjustment of the lower back support in the upper section of the seat back (235)
- Adjustment of the lower back support in the lower section of the seat back (236)
- Adjustment of the seat height, adjust rotary handle (233) to the driver's weight

Heating / ventilation

The crane cab can be heated or ventilated according to the desired temperature. The operating elements for heating/ventilation are found underneath the cab operator's seat.

Operation:

- Ventilation Pre-select air distribution above / below by opening / closing the air outflow (234).
 Activate crossover switch (232) for fresh air.
 Switch on the blower with rotary switch (230).

- Heating See also Chap. 6.01 "HEATING"

Heating can be switched on with switch (317); the indicator lamp (316) indicates that the heater is operationally ready.

Pre-select air distribution above / below by opening / closing the air outflow (234).

Activate switch (232) for recirculated air.

Switch on the blower with rotary switch (230).

Temperature can be controlled with regulator (231).

Seat heater *

The seat can be heated by switching on switch (302).

Air conditioning *

See enclosed separate operating instructions.

Switch air conditioning on with switch (314), indicator light (315) lights when air conditioning is ready for operation,

Pre-select air distribution above / below by opening / closing the air outflow (234).

Switch change-over switch (232) to recycled-air mode,

Switch on the fan with rotary switch (230).

* Optional

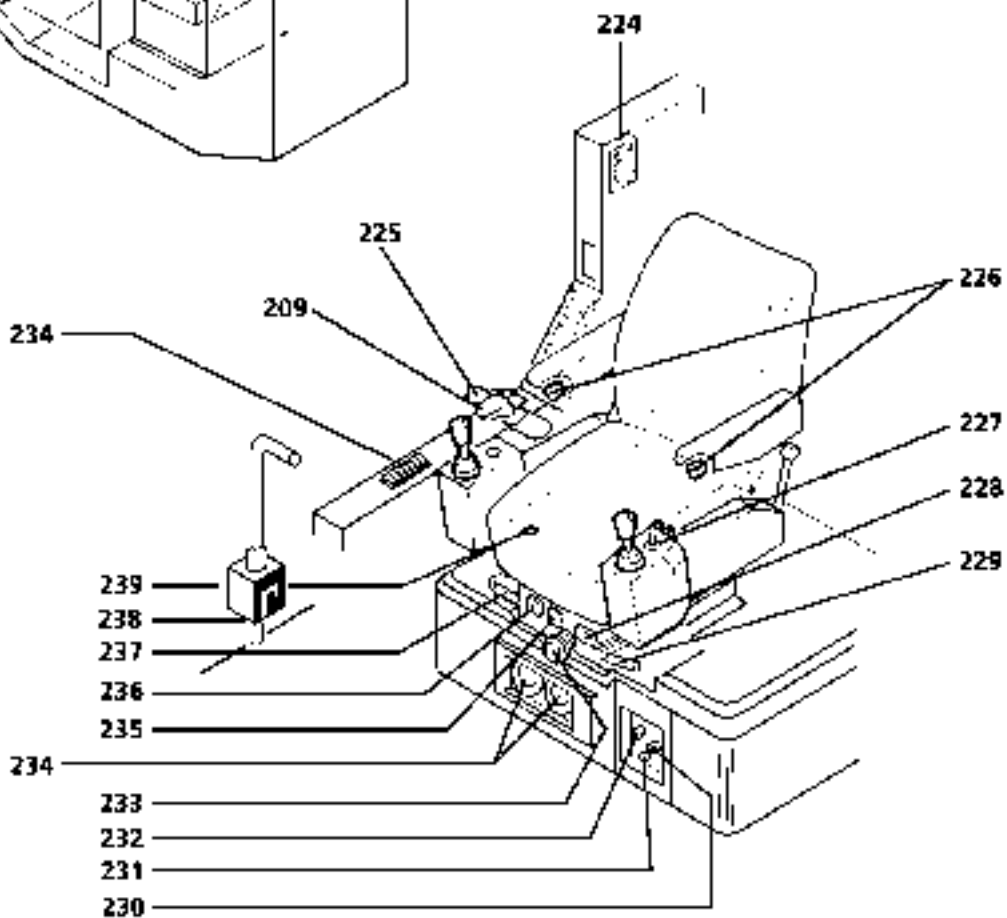
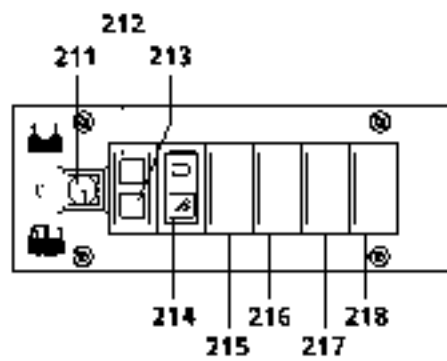
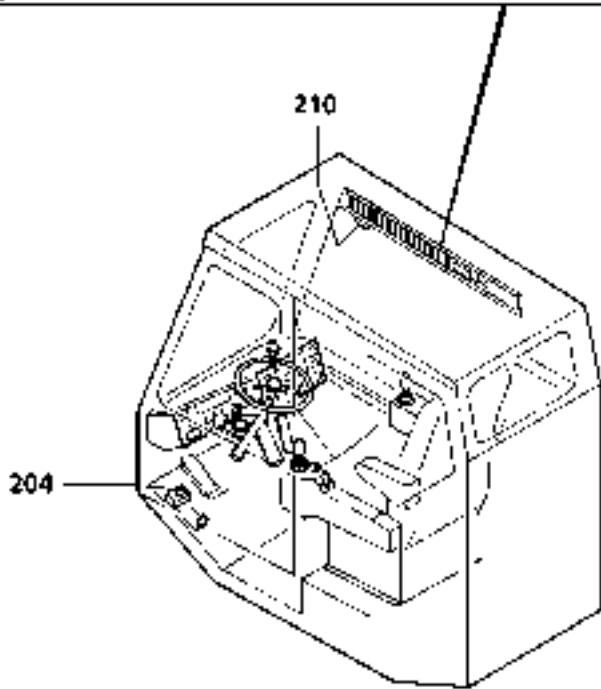
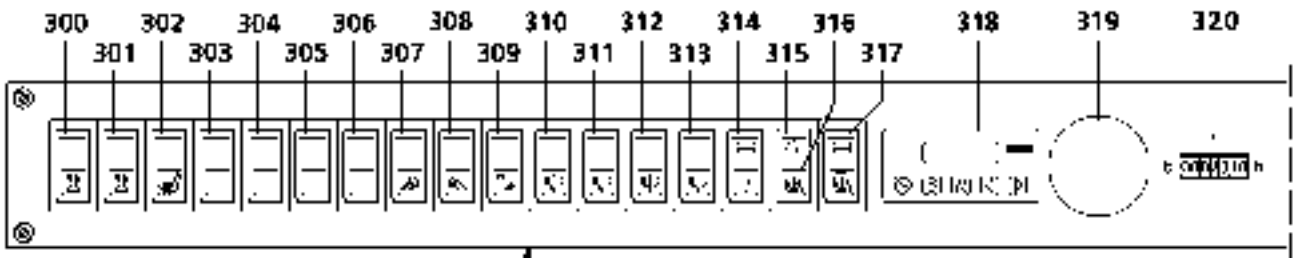

Windshield wipers

The windshield wipers on the front windshield as well as the roof window can be activated with switches (311 and 313).

1st stage - Interval
2nd stage - Normal

Front windshield

The front window may be opened by simply pushing it from the inside. Its travel is aided by a pair of nitrogen cylinders. If the window only needs to be partially opened, it can be secured on the perforated belt to the desired angle.

D A N G E R : **There is the danger of injuring the hands by closing them in the window.**

Horn

Before beginning work, the horn must be tested with the foot switch (204).

D A N G E R : **The horn should only be used in dangerous situations to ensure its effectiveness on all personnel working around the crane.**

Lighting

The operating spot lights on the front of the cab are switched on with (214).

The working lights on the cab roof* and the boom head* are switched on with switch (215).

The interior area is lit with a dome light; activate switch (210).

Instrument panel lighting

The instrument panel lighting can be switched on / off with switch (270).

* Optional

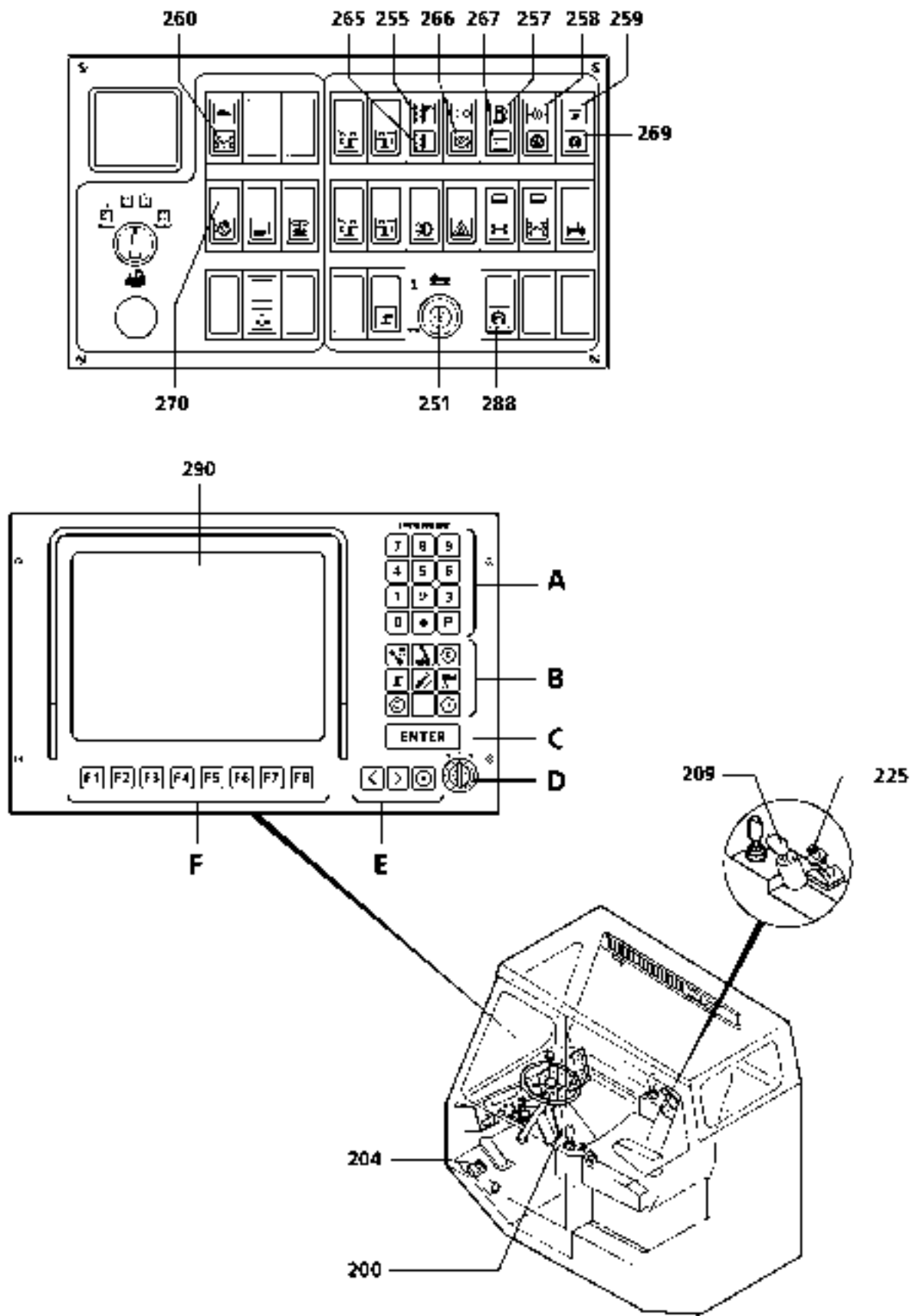

See also Chap. 3.04, "DRIVING ON PUBLIC ROADS".

Engage the parking brake (manual brake 225)

When the brake is closed, the hand lever points up. Indicator comes on.

Note: To engage the parking brake, pull the lever out fully on its longitudinal axis and turn it upwards.

CAUTION: The hand brake must be engaged in the driver's cab as well as in the crane operator's cab.

Switching over to "crane operation"

The engine is at standstill, switch gear selector (209) switch to neutral position "N".

Switch on ignition in the driver's cab.

Switch switch (97) to position "axle suspension locked", indicator light in switch must light up.

Switching on the crane hydraulic system

Switch change-over switch (15) to position "superstructure".

Indicator lights (48) in the driver's cab and (260) in the crane cab must light up, the crane operation hydraulic pump is then switched on.

CAUTION: If control lights (48) or (260) do not light up, the change-over switch (15) must be switched back to "crane chassis".
Start the diesel engine and let it run until the compressed air system has built up operating pressure.
Shut the engine off again and change-over switch (15) into "superstructure" position.

Switch off the ignition in the driver's cab.

The following functions are now switched over to the crane cab:

Steering, gear selection, hand brake, electrical system.

Switch on the ignition in the crane operator's cab, Instruments check

Insert the key into the ignition (251) and turn one notch clockwise.

The following indicator and warning lamps will come on:

- Indicator light (266) parking brake,
- Indicator light (260) crane hydraulics switched on,
- Indicator light (259) preheating,
- Battery charge (267),
- Engine oil pressure (258),
- Oil pressure too low in power shift reversing gearbox (269),
- Fuel level (257),
- Slewing platform position (255 or 265).

Note: If indicator lamp (265) is on, in order to drive in the direction of vision, the reverse gear must be selected.
Warning lamp (257) will come on if the fuel level in the tank is too low.

CAUTION: The crane must never be driven until the fuel tank is empty as residue and dirt can be ingested - if this happens, the fuel system must be cleaned and ventilated. Never drive to the point where the fuel level warning lamp (257) comes on; always tank when necessary.

DANGER: Defective lamps must be replaced before beginning any work.
If the crane is operated without functioning warning devices, accidents could result.

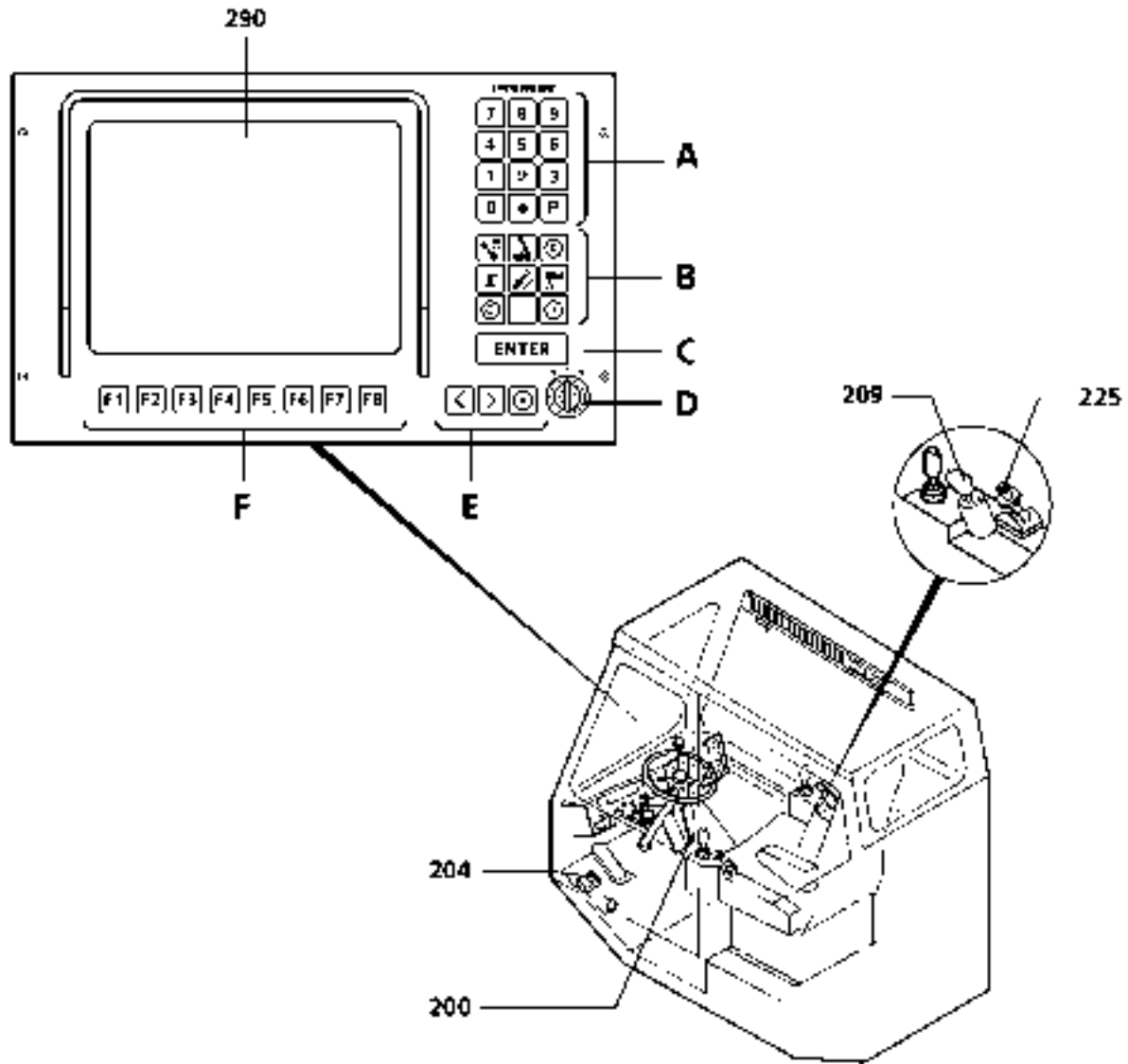
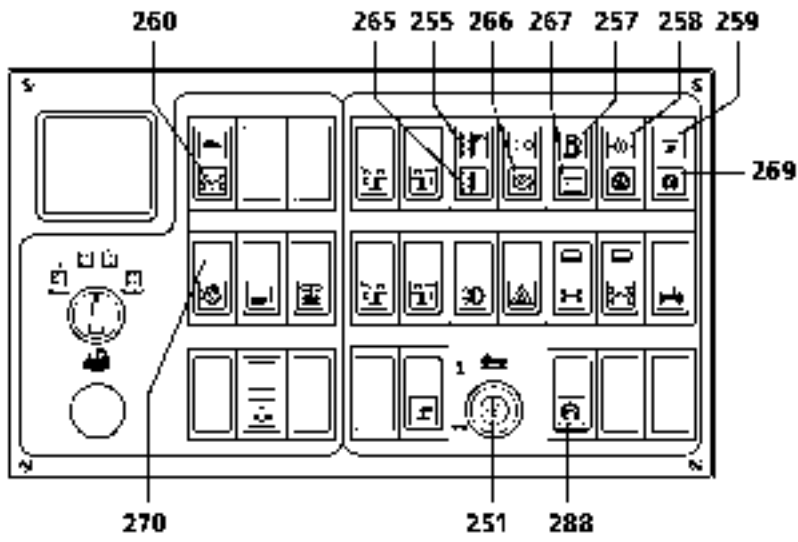

Start the engine

CAUTION: The engine must only be started once the Indicator light crane hydraulic system (260) lights and the preheat indicator lamp (259) blinks.

Starting with the flame glow device

At temperatures below zero, always start the engine with the flame glow device, making sure to observe the correspondingly longer preglow times. This reduces not only the starting limit temperature, but also makes starts easier at temperatures which do not actually require starting assistance.

Using afterignition to prevent starting exhaust smoke is also possible if starts are carried out from the beginning with the flame glow device (preheat).

Note: The flame glow device is automatically switched off at engine water temperatures above +20 °C.
Should the flame glow plug fail or be defective, the preheat indicator lamp will **not** come on.

Starting procedures at outside temperatures below 0°C.

1. Preheating

Switching the ignition (251) to position "1" (Drive) initiates the preheat time, which is approximately 40 - 50 seconds.

Preheat time is indicated by the blinking indicator lamp (259).

If the engine is started during preheat, the preheat operation is automatically interrupted. In this case repeat the preheat procedure.

2. Starting the engine

At the conclusion of the preheat time, indicator lamp (259) will go out and the start readiness time, which is approximately 30 seconds, will then begin.

The engine is started by then turning the ignition switch (251) to position "2" (Start).

The charge indicator lamp (267) must come on.

Note: Always start the engine without using the foot pedals (200).

If the engine is **not** started during the readiness for start time, start readiness is automatically disengaged. In this case repeat points 1 and 2.

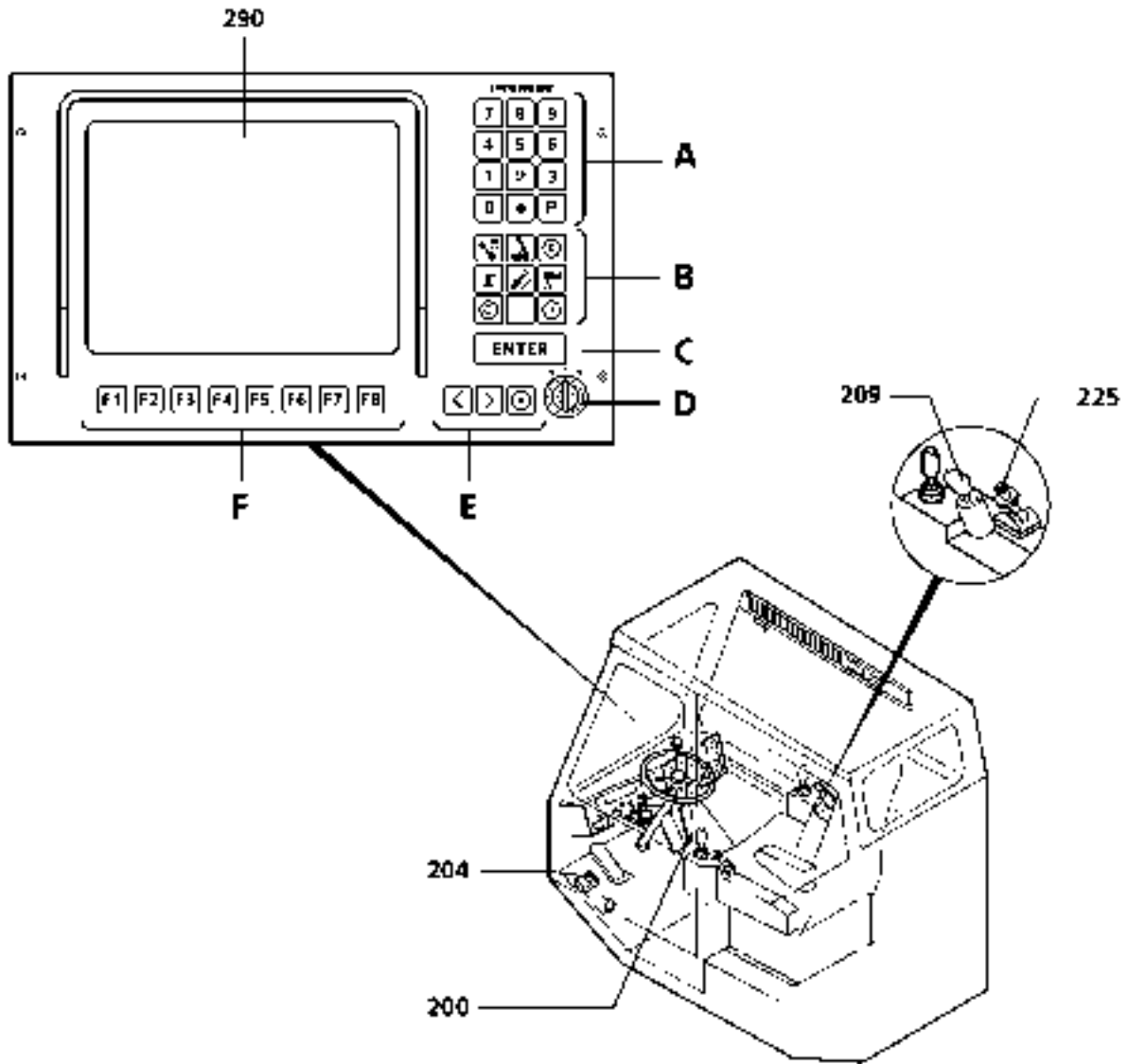
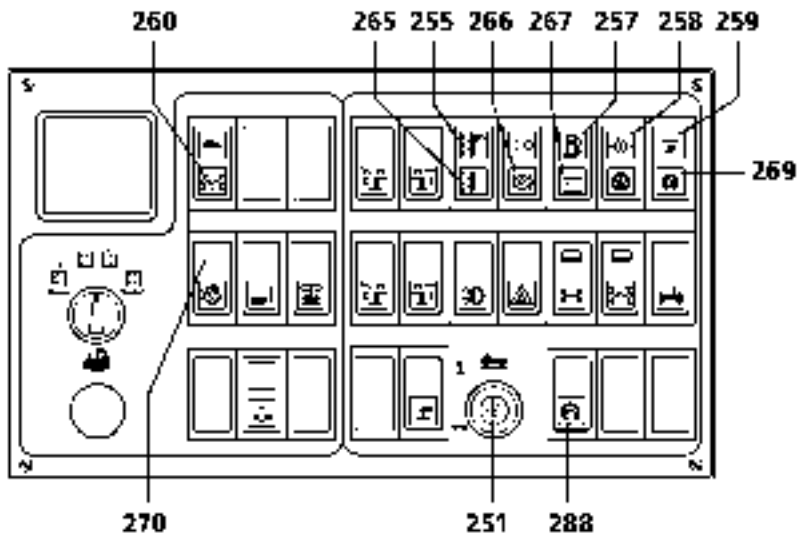

If the engine does not start after approximately 5 seconds, slowly press the accelerator (200) pedal all the way to the floor.

If the engine still fails to start after approx. 20 seconds, give up the attempt and wait approximately 1 minute before trying again.

The starter may be run 3 times at 20 seconds each time, with a 1-minute pause between each starting attempt. After starting, observe the oil pressure warning lamp (258).

CAUTION: If this warning lamp does not go out, or if it comes on during crane operations, the engine must be switched off immediately.

If this is not done, the engine could be damaged due to the absence of oil pressure.

The engine must be switched off immediately in case of:

- reduction or extreme fluctuations in oil pressure
- reduction in output and rpm without a change in the speed adjustment lever position
- strong exhaust smoke or soot as well as an increase in the exhaust manifold temperature
- increase in coolant and oil temperature
- suddenly occurring abnormal noises from the engine or turbo-supercharger.

If the engine is **warm**, start it **without** depressing the accelerator (200) to avoid soot emission.

Engine running - instrument check

Observe the oil pressure warning lamp (258) immediately after starting the engine.

As soon as the batteries are charged via the generator and stable voltage is present, the electrical crane control and the LICCON overload safety device switch on automatically.

The microprocessor system then carries out a self-test.

If no errors are found, the first image (equipment mode diagram) will appear on the screen (290) after a few seconds.

The equipment mode diagram most recently worked with always appears first.

The following indicator lamps must go out while the engine is running:

- Battery charge lamp (267)
- Engine oil pressure lamp (258)

3. Shutting the engine down

- Relieve engine loads and gradually reduce rpm in order to prevent the coolant from heating; then, let the engine run briefly in idle, allowing the turbo-supercharger time to run down.
- Shut the engine down via button (288).

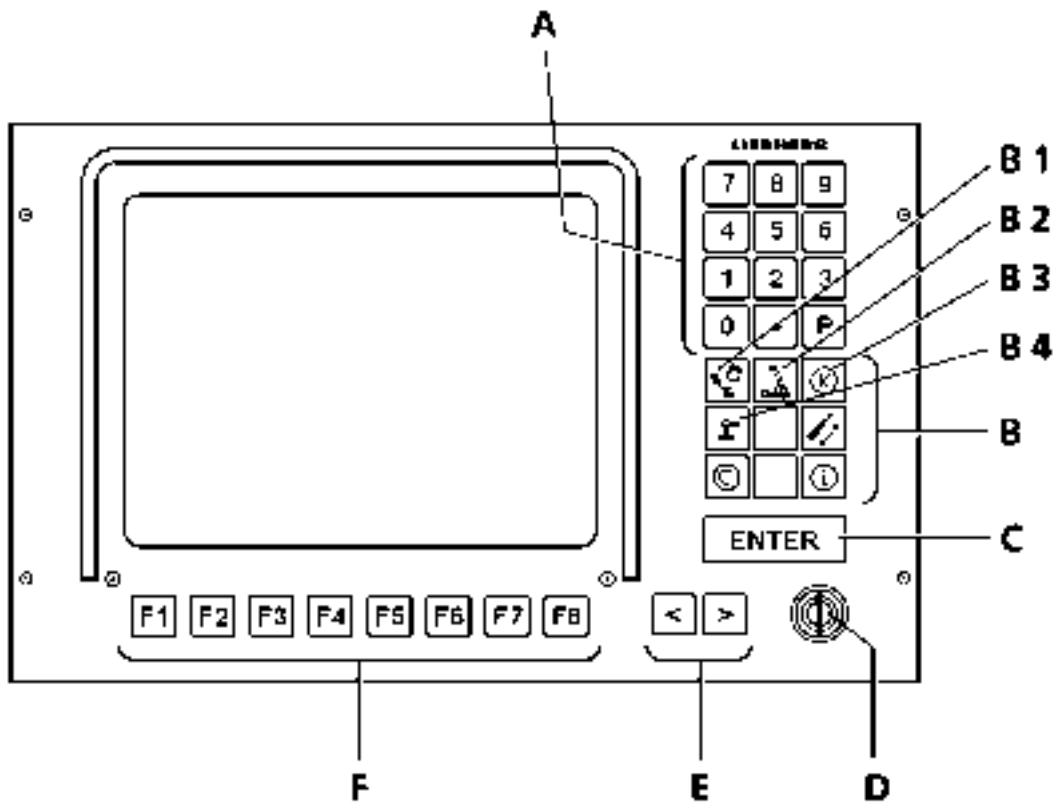

Check the safety devices

The crane operator must be convinced before each operation of the crane that all the safety devices are fully functional.

DANGER: If the crane is operated without functioning warning devices, accidents could result.

LIEBHERR COMPUTED CONTROLLING (LICCON)**Overload safety**

The electronic overload safety device shuts down all crane movements which **increase the load torque**.

Only those crane movements resulting in a **decrease in the load torque** can still be carried out.

However, the fact that the crane is equipped with a load torque limiter does not free the crane operator from responsibility with regard to operating safety.

The operator must be aware of the approximate weight of any load to be lifted before attempting to lift it, and must refer to the load capacity tables to make sure that the crane is equipped to lift such a load.

DANGER: The overload safety device is an important piece of safety equipment and must not be used as a shutdown device to allow impermissible crane movements to be carried out, i.e., when extending or lowering the boom with a suspended load.

The overload safety device can only fulfil its function properly if it is set to match the crane's equipment mode as stated in the load capacity tables before the crane is operated.

If the crane operator fails to fulfil his safety obligations, the crane could overturn and be damaged beyond repair, despite the fully functional load torque limiter, which cannot be expected to monitor and control all possible operating conditions.

Assembly-key operated switch "D"

By turning the key in the assembly key-operated switch **D** to the right, the overload safety device is bypassed.

This is necessary and permissible for assembly procedures.

During crane operation, the "LICCON" overload safety device may not be by-passed under any circumstances.

See extensive separate "LICCON" operating instructions.

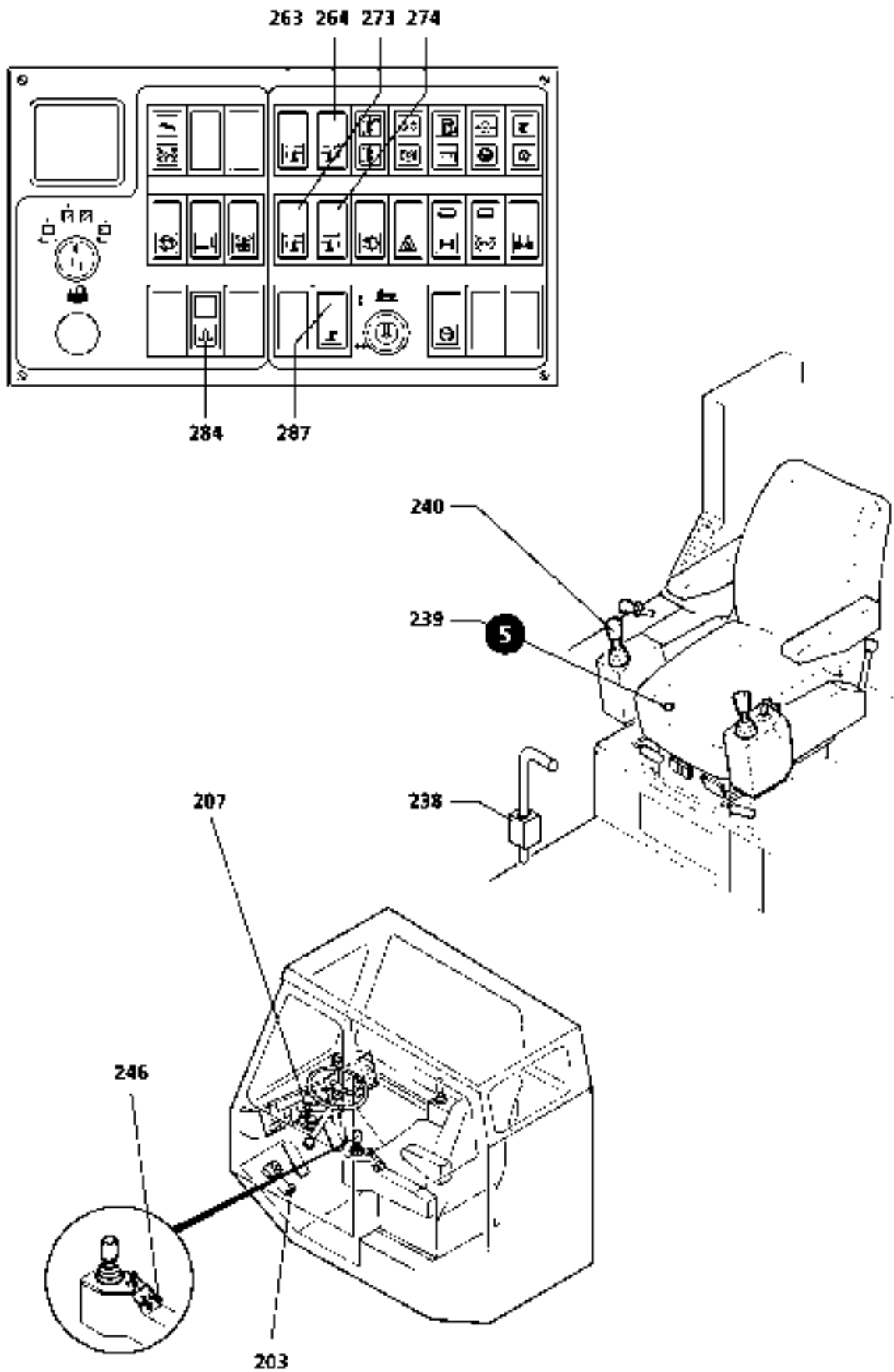

Button Control enable (287) for support

If crane support is to be carried out from the crane cab, the button (287) must be kept depressed while one of the buttons (263, 264, 273, 274) responsible for support is operated.

This safety switch is integrated in order to prevent the crane from reaching a critical inclination angle due to unintentional activation of the buttons responsible for horizontal alignment.

D A N G E R: **The stipulations in Chap. 3.05 MUST be observed and adhered to!**

Seat contact switch (S) (239)

When working while seated, control enable for the crane is carried out via the seat contact switch (S) (239)!

Foot switch "control enable" (203)

If the crane operator works standing up, this switch (203) must be kept depressed.

When working seated, the switch is bypassed via the seat contact switch (S).

Note: This safety device is provided to prevent unintentional crane movements which may be accidentally caused by contact with the hand control lever while exiting or entering the cab.

Button "topping boom at overload" (246)

When the crane is overloaded, the boom topping movement is shut down, although it would in effect, with a freely swinging load, decrease the load torque.

By pressing button (246) and moving the manual control lever (240) in the "topping" direction, boom topping movements can nevertheless be carried out.

D A N G E R: **This must NEVER be used to lift a load with the luffing gear if the load torque limiter has already tripped when attempting to lift the same load with the hoisting gear.**
This could lead to overloading and in turn could cause the crane to topple over.

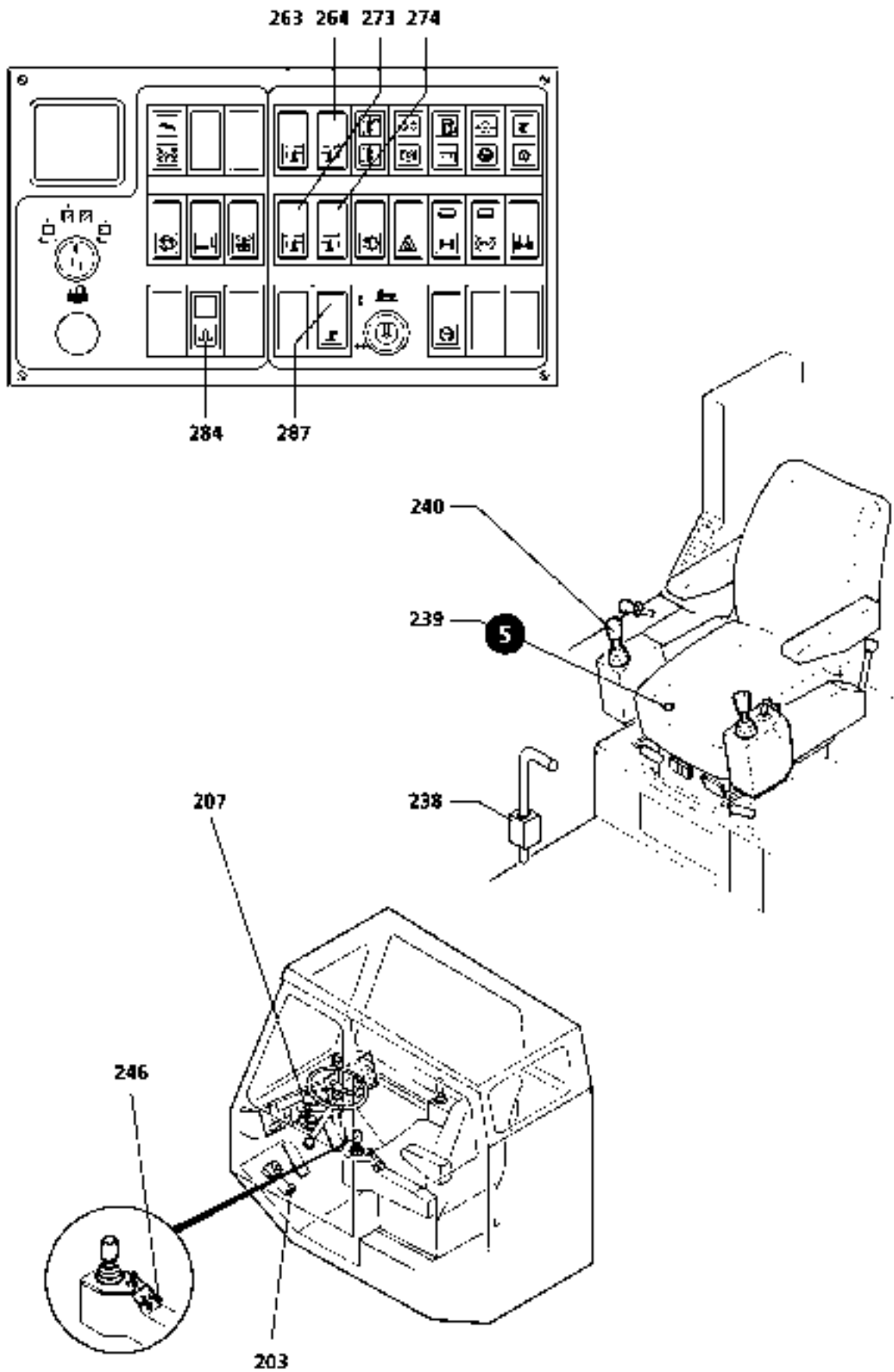

Contact switch on crane slewing platform locking pin (238)

For crane operating modes "**to the rear**" and "**free-standing on wheels**", the crane superstructure must be mechanically locked to the chassis.

C A U T I O N : Indicator light (284) must light up!

When the superstructure is locked, a contact switch on the locking pin switched on indicator light (284) and the "LICCON" overload protection device is released for "**free-standing on wheels**" and "**to the rear**".

Levelling instruments (bubble gauges 207)

In order to ensure safety while working with the crane, it must be aligned horizontally.

The air bubbles in the bubble gauges left and right on the vehicle frame as well as in the crane cab must be in the inner ring.

D A N G E R : The crane must be aligned horizontally in order to prevent accidents.**Note:**

Maximum permissible deviation from the horizontal is $\pm 0.5\%$ ($\pm 0.3^\circ$).

The air bubbles in the bubble gauges must be in the innermost ring.

If the bubble gauges become maladjusted as a result of external forces, they must be reset.

To do so, first align the crane exactly horizontally in a longitudinal and lateral direction with reference to a spirit level placed on the slewing ring, or as near as possible to the slewing ring on the chassis.

Then reset the bubble gauges using the adjusting screws and secure them at the correct setting with the locknuts.

The setting of the bubble gauges will not alter during normal travel and crane operation.

Limit switch hoisting gear (Winch) spooled in / spooled out

The cam limit switch built into the winch switches off the crane movement "**lower**" when there are still at least 3 safety loops remaining on the cable spool.

Similarly, spooling in is stopped when the winch is fully spooled.

D A N G E R : During assembly operation when the hoisting cable is being spooled in, make sure the cable end remains in front of the winch and that it is not spooled in over the winch. If the cable end is pulled one further rotation over the winch, the switch off safety function (after reaching the 3 safety loops), is no longer guaranteed.

The cam limit switch must then be reset.

Furthermore, when a new hoisting cable is replaced, the cam limit switch must then be reset so that it switches off when there are still 3 remaining loops in the spool. If this is not done, the inner cable attachment can be torn out, resulting in the load falling.

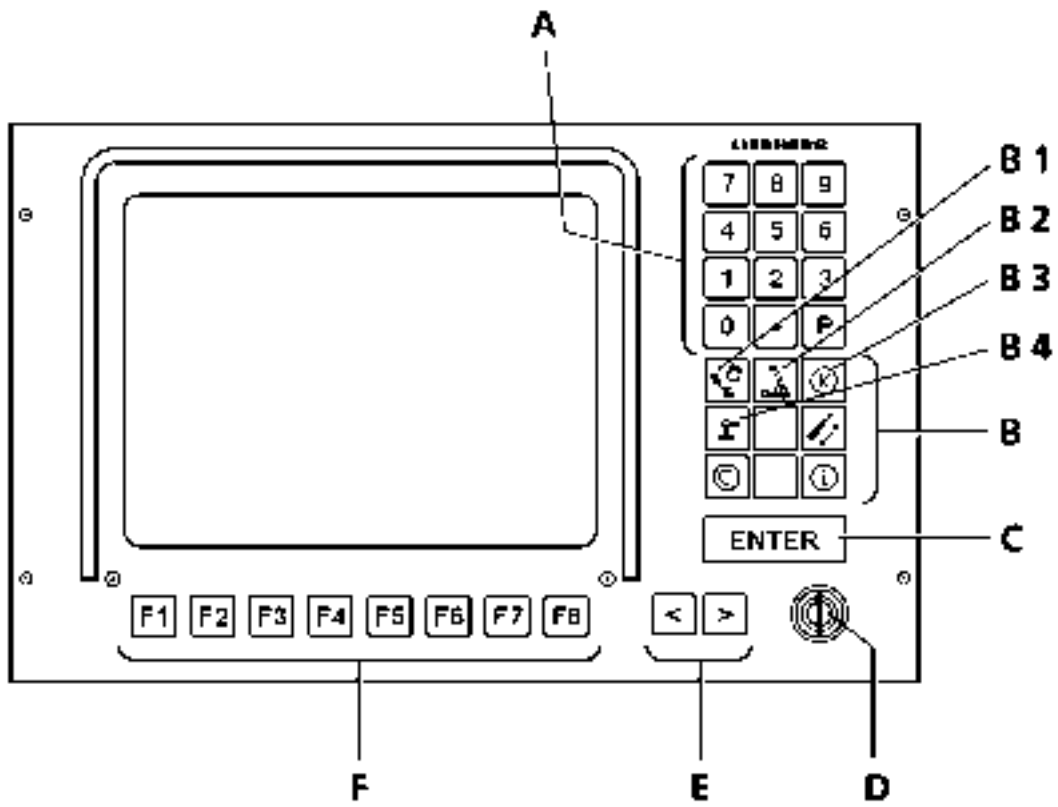

Hoisting limit switch - upper limit of hoisting movement

The hoisting limit switch is designed to prevent the hook block running up against the boom head.

On each occasion before the crane is operated, run the hook block up against the limit switch weight to check that the switch is functioning properly.

All "hoisting", "luffing", and "telescoping" movements of the crane must be switched off.

DANGER: The hoisting limit switch may only be bypassed during crane operations with the assembly key-operated switch if an observer carefully monitors the distance between the hook block and the boom head.
The observer must be in direct contact with the crane operator.
The hoisting movement must be carried out with the utmost care and at the lowest speed possible.
Bypassing the hoisting limit switch is only permitted in an emergency situation by authorized persons!

Rotation indicators Hoisting gear I or Hoisting gear I and II *

Integrated in the "LICCON".

Switch on equipment mode diagram with the program key (B2).

The rotation indicator on the screen indicates that the winch is turning, even when multiple reeving and slow speed make movement of the hook block difficult to observe.

CAUTION: When spooling in, make sure (by observing the winch) that no loose cable is wound in - loose cable can damage the winch cables.

Wind speed warning device *

Integrated in the "LICCON"

Switch on equipment mode diagram with the program key (B2).

A wind gauge symbol appears on the screen of the "LICCON". This shows the current wind speed. See separate "LICCON" operating instruction.

If the maximum permissible wind speed is exceeded, a warning signal will sound and the wind speed display will blink.

DANGER: If the permissible wind speed is exceeded, shut down is not carried out automatically.
Crane operations must be ceased and the boom must be lowered.
Operating when the wind exceeds the permissible speeds increases the risk of accidents.

CAUTION: When operating with the folding fly jib, the wind sensor, which is detachable, must be mounted and fully functional - otherwise, the "LICCON" overload safety device will indicate a malfunction.

Hydraulic safety valves

Pressure limit valves for preventing hose and pipe ruptures.

Shut-off valves in the luffing, telescoping and support cylinders.

* Optional

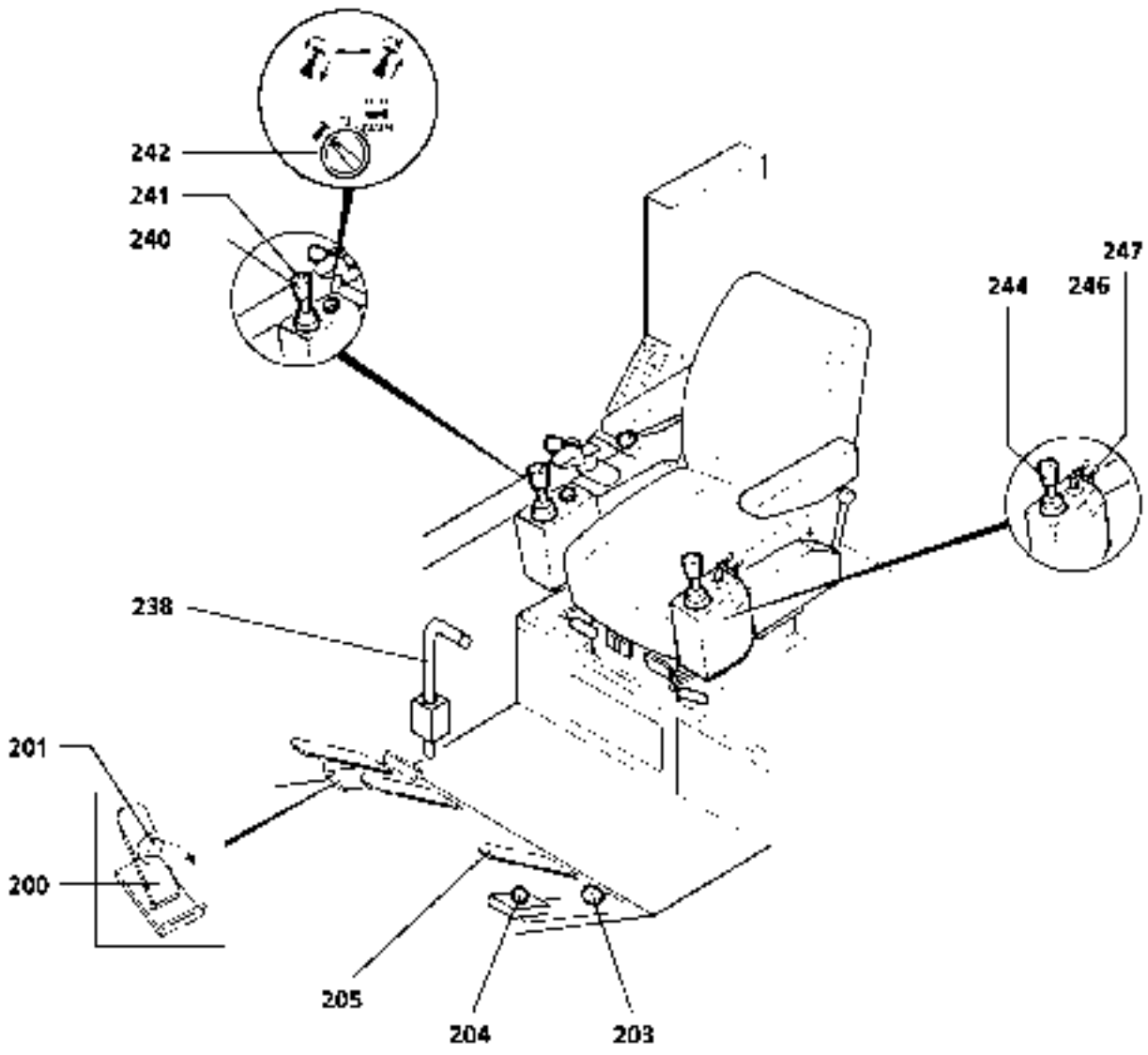
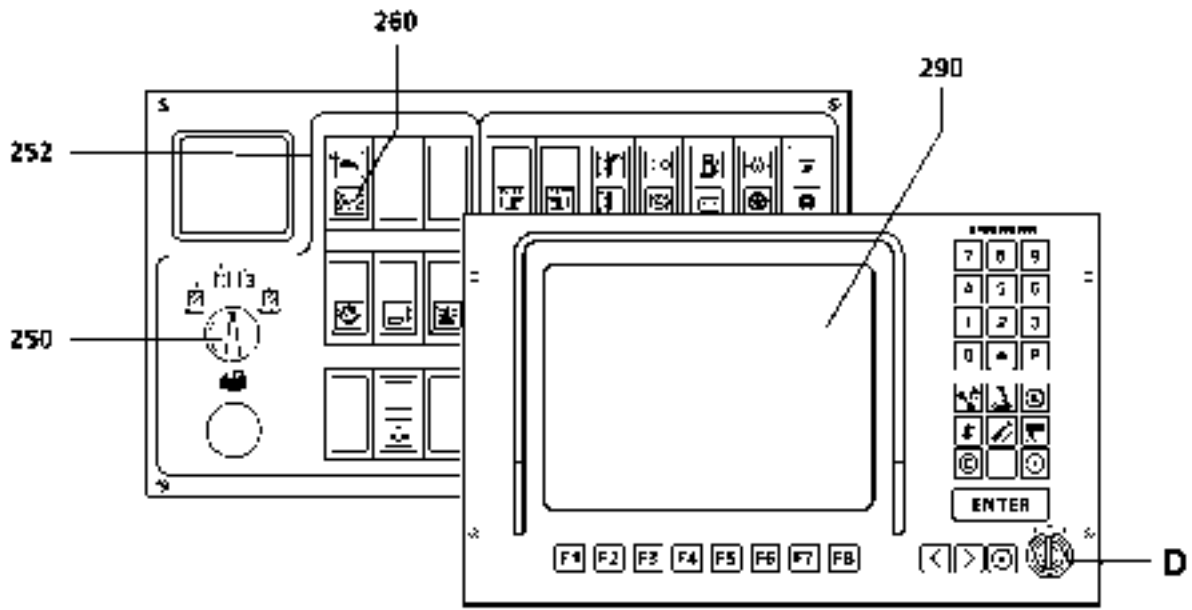

Requirements:

- The crane operation hydraulic pump is switched on,
- Indicator light (260) is lit.
- The crane is supported and horizontally aligned in accordance with the load capacity table.
- Ballast(s) is mounted and secured in accordance with the load capacity table.
- The diesel engine is running.
- Hook block is properly reeved in according to the reeving chart.
- All safety devices are set in accordance with the load capacity table.
- Danger zone free of personnel and objects.

CAUTION: Always operate the hand control lever slowly and carefully. This not only ensures longer crane life, but also helps to avoid accidents.

DANGER: During all crane movements, always make sure there are neither obstacles nor persons in the danger zone. Before initiating any crane movements, a warning signal (signal horn) must be given.

Diesel engine running

Note: The diesel engine idle speed can be raised to ca. 1200 rpm for crane operation.

To do this, move the lever (201) on the accelerator pedal (200) out of the "ZERO" position (upper right) down and to the right and depress the accelerator pedal (200) briefly. If the increased idle speed is no longer required, the lever (201) must be placed back in the "ZERO" position.

Up to four crane movements can be driven simultaneously via the LOAD SENSING hydraulic system. If the engine speed is lower, switching on each additional crane movement cause the working speed of the first movement to be reduced. This situation can be avoided by raising the engine idle speed accordingly and, or switching off one or the other crane movement.

As soon as the batteries have been charged by the generator and stabile voltage is available, the electrical crane control and the "LICCON" overload safety device automatically switch on. The microprocessor system carries out a self-test. If no errors are detected, the first diagram (equipment mode diagram) appears after a few seconds.

The last equipment mode diagram in which operations were carried out always appears.

Note: The crane controls are released once the seat contact switch is depressed, the crane operator sits on the seat. In order to preclude the possibility of unintentional crane movements due to accidental movement of the hand control lever, the crane steering is disengaged by the seat contact switch as soon as the crane operator stands up. If the operator must work in standing position, the seat contact switch can be bypassed using the foot button (132)

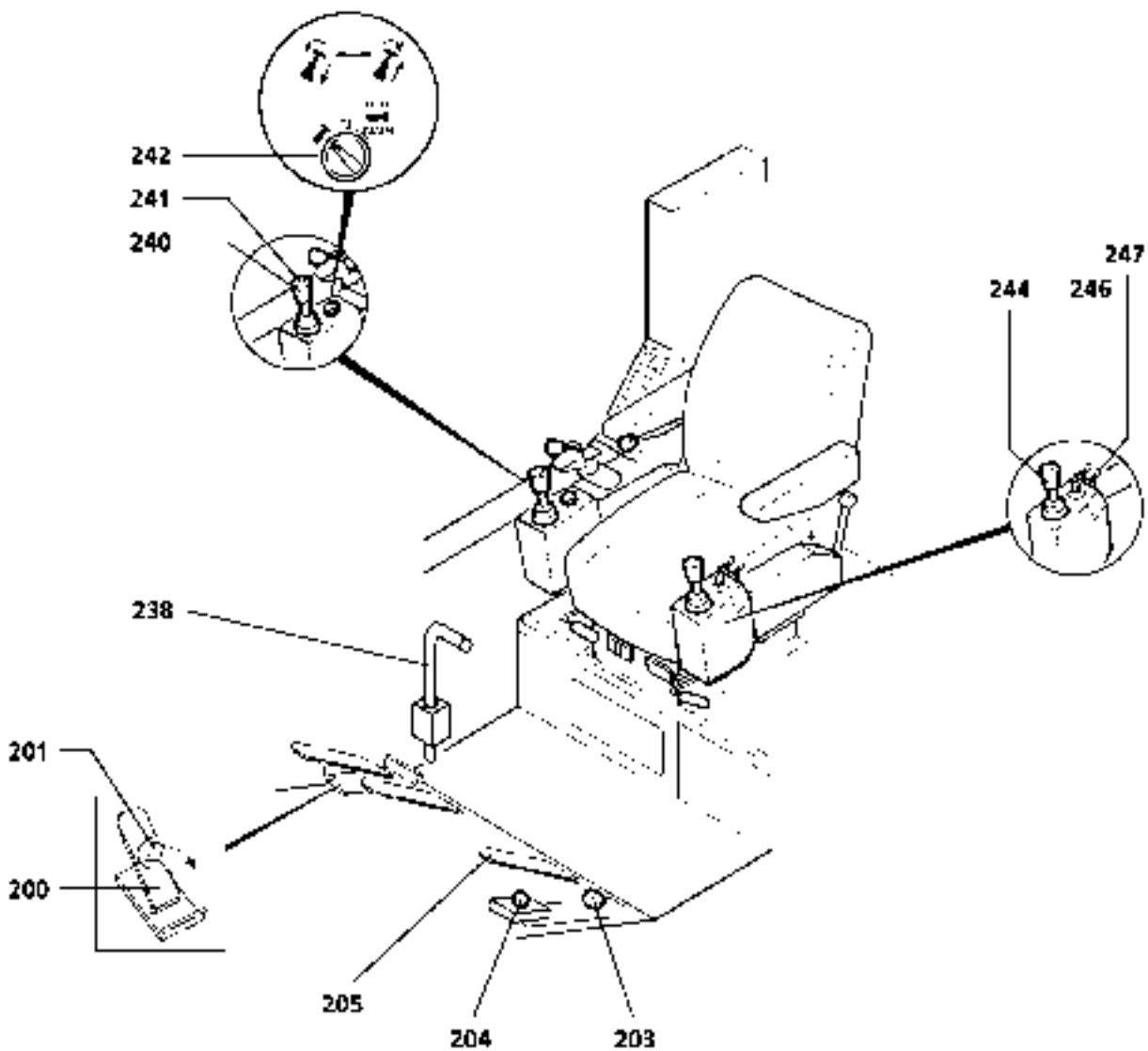
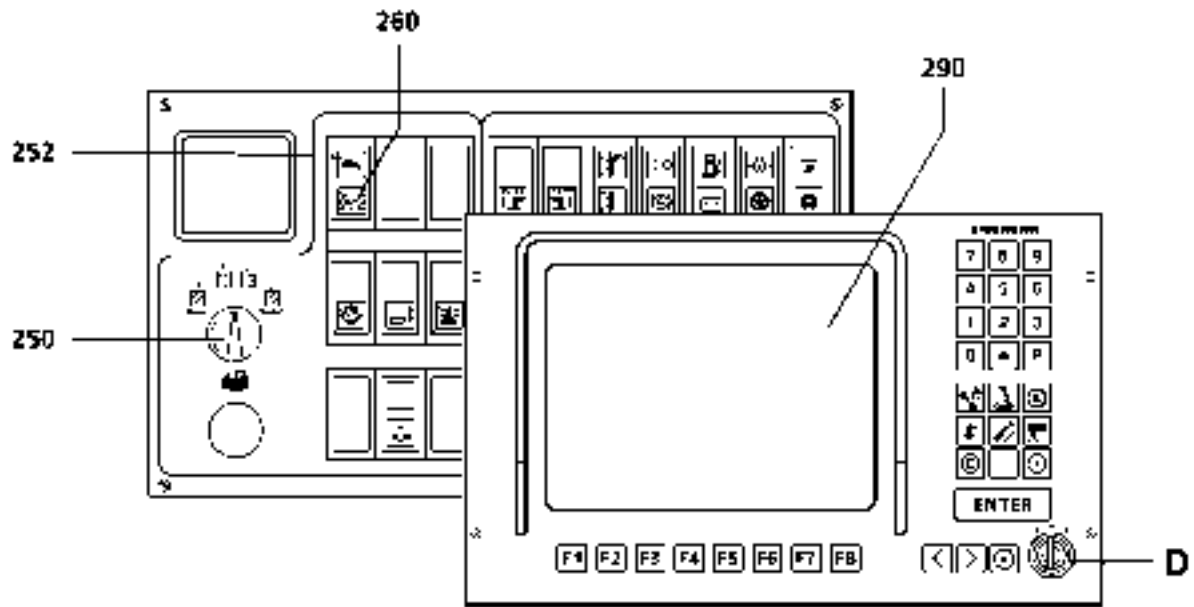

With one hoisting gear**Crane movement "raise / lower" with hoisting gear I**

Move the hand control lever (240) forwards = "lower hoisting gear".

Move the hand control lever (240) to the rear = "raise hoisting gear".

The speed of the crane movement is controlled by varying lever travel and engine speed.

A further increase in speed, for "raise / lower" can be achieved by switching on the high-speed; to do this

- Press "High-speed" key (241).
- High-speed is now stored, and is indicated by indicator lamp (252), until the "high-speed" button (241) pressed again and the indicator light (252) shuts off.
- Initiate lowering or raising movements by moving the manual control lever (240).

DANGER: For 1 - 3 cable reevings, switching to high-speed is prohibited if the crane is loaded to more than 50% of its maximum permissible load capacity at the current working radius.

CAUTION: When spooling out the hoisting cable of hoisting gear 1, make sure (by observing the winch) that no loose cable is wound in - loose cable can damage the winch cables.

Crane movement "luffing" the boom

Move the hand control lever (240) to the right = "boom luffs down"

Move the hand control lever (240) to the left = "boom luffs up"

The speed of the crane movement is controlled by varying lever travel and engine speed.

A further increase in speed, for "luffing up" can be achieved by switching on the high-speed; to do this:

- Press "High-speed" key (241).
- High-speed is now stored, and is indicated by indicator lamp (252), until the "high-speed" button (241) pressed again and the indicator light (252) shuts off.
- Initiate the boom topping movement by moving the hand control lever (240).

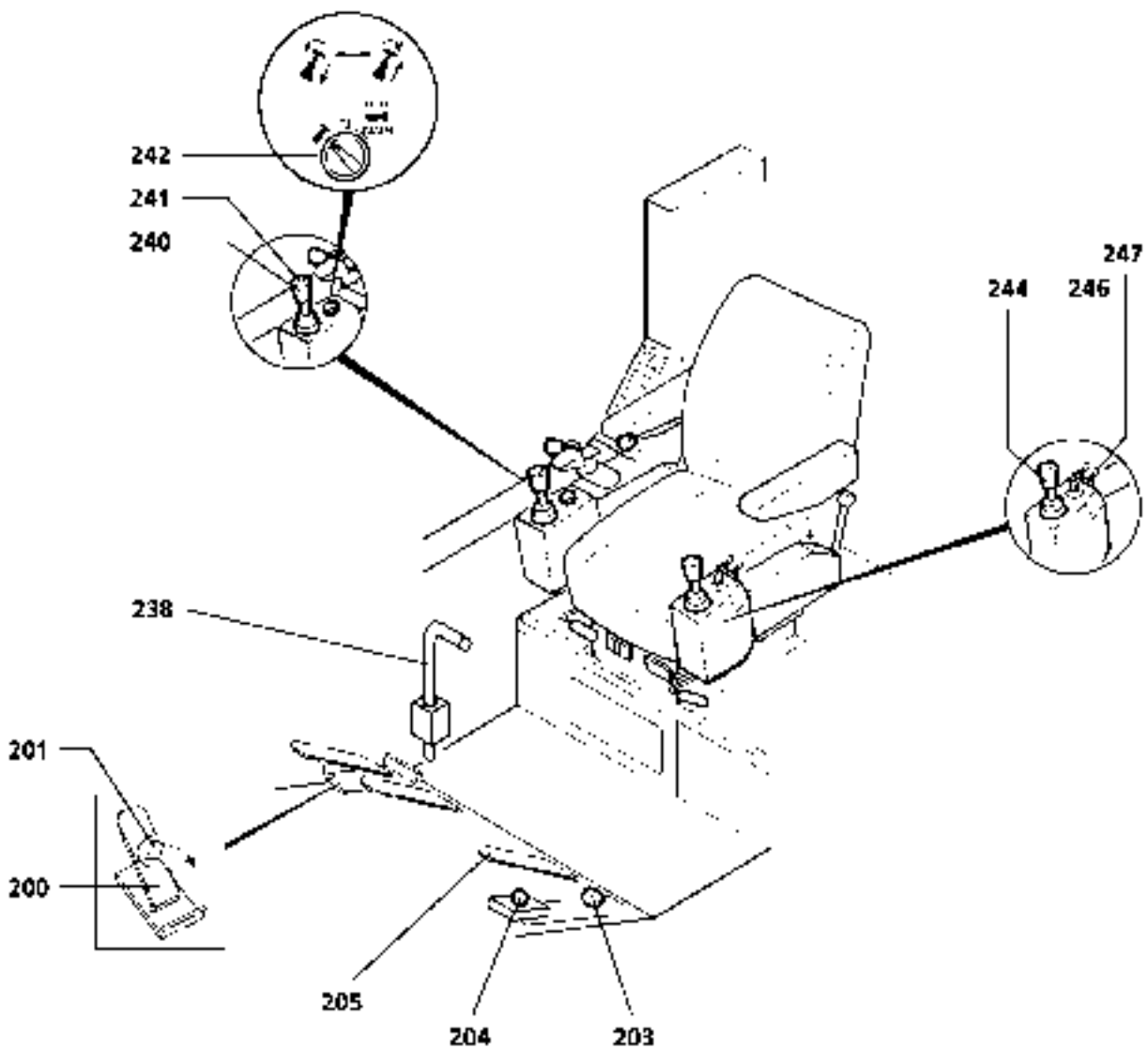
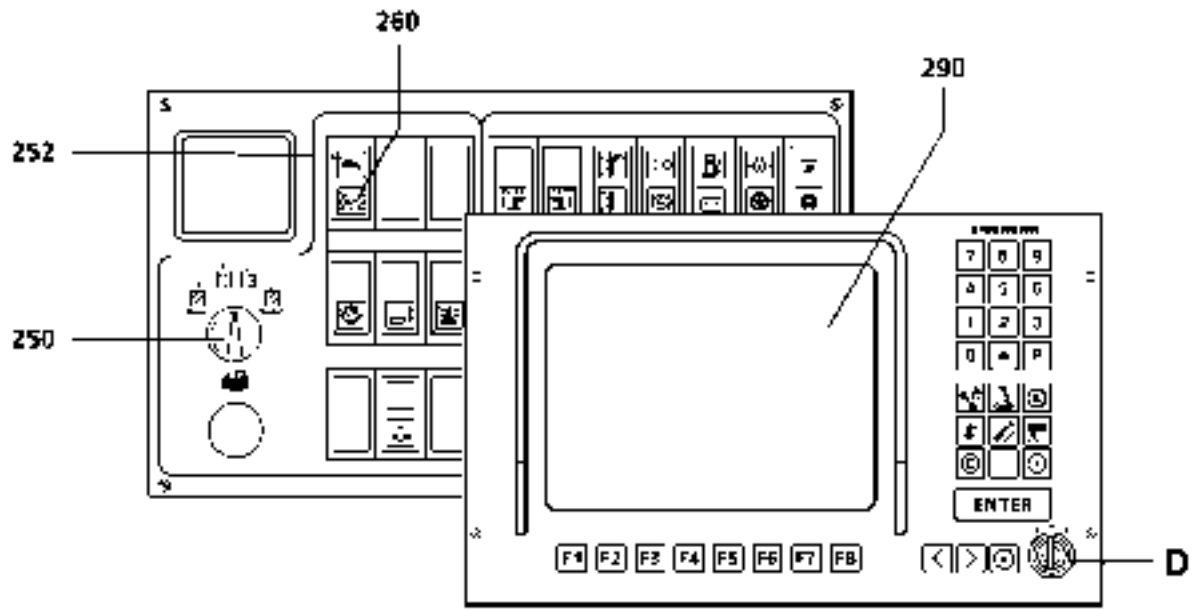

With one hoisting gear**Crane movement "telescoping" the boom**

The telescopic sections must be extended to the required length in accordance with the load capacity table by activating the manual control lever (244).

Each extension is assigned a 2-place code number.

This code number is taken from the current operational load capacity table and is input via the LICCON keypad.

Note: Refer to the separate "LICCON" operating instructions.

Move the hand control lever (244) forwards = **"extend telescope"**.

Move the hand control lever (244) to the rear = **"retract telescope"**.

The speed of the crane movement is controlled by varying lever travel and engine speed.

The speed of the crane movement **"extend telescope"** can be increased by switching on the high-speed; to do this:

- Press "High-speed" key (241).
High-speed is now stored, and is indicated by indicator light (252), until the "high-speed" button (241) is pressed again and the indicator light (252) shuts off.
- Initiate the telescoping out movement by moving the hand control lever (244).

CAUTION: In normal operations, the telescopic boom is extended without a load to the required length, and only then loaded.

However, it is possible to extend the telescopic boom under partial load.

This partial load is dependent on the lubrication of the bearing pads as well as the available useable length of the boom.

The maximum permissible partial load is limited by the pressure setting on the pressure relief valve of the telescope cylinder.

The partial load indicated on the LICCON must never be exceeded!

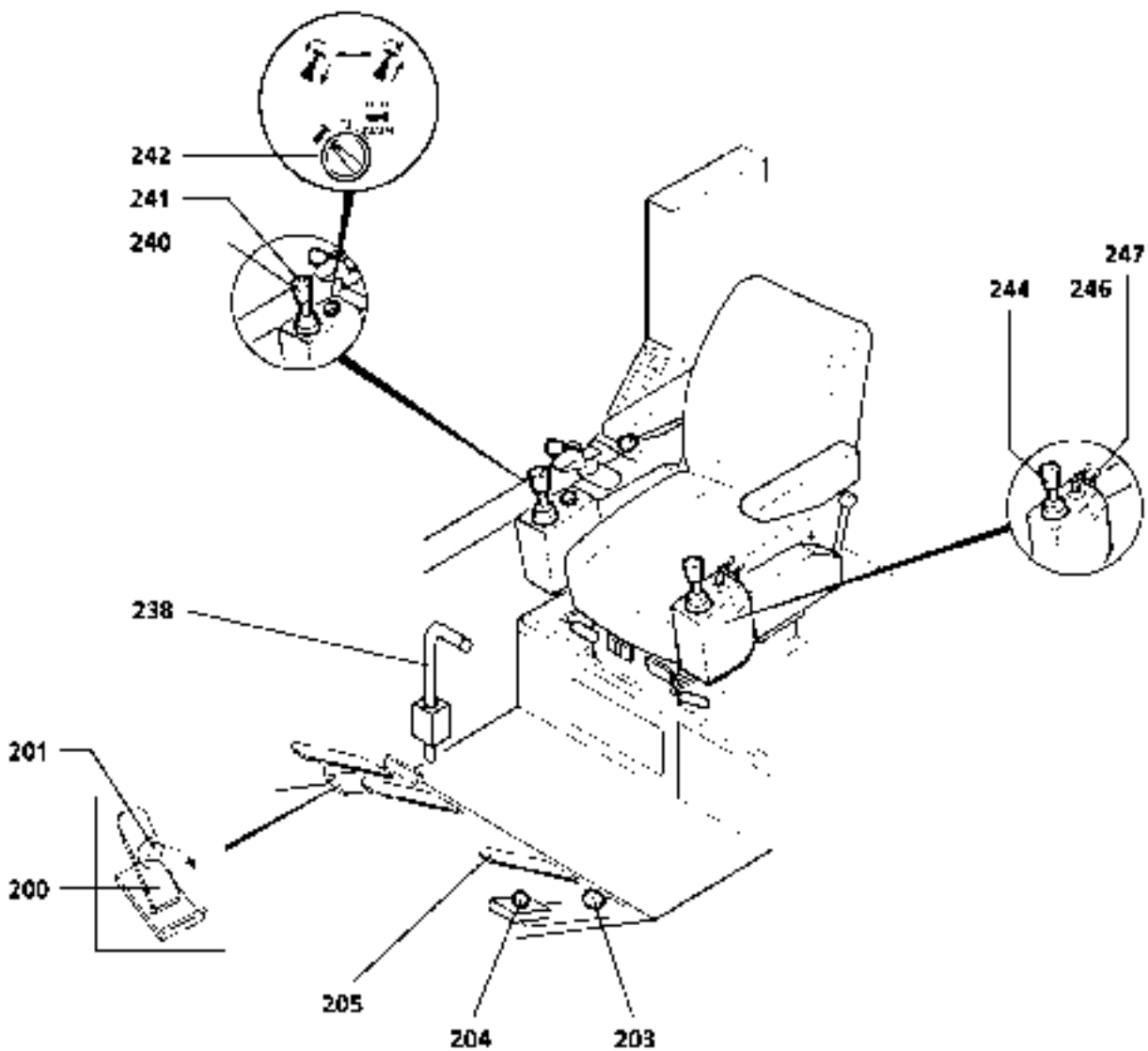
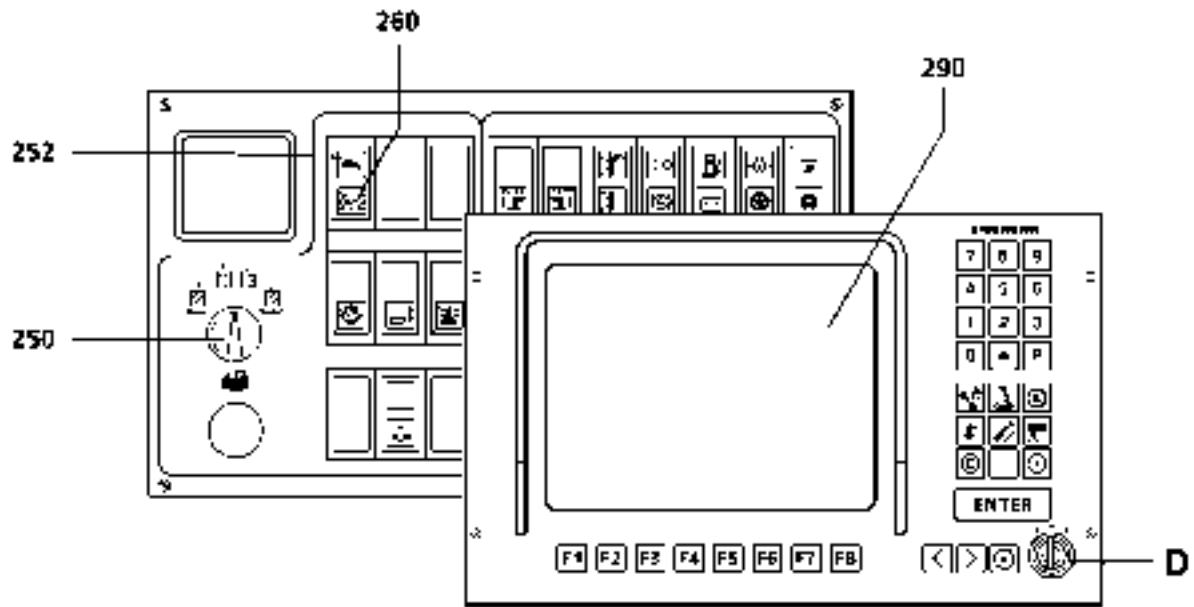

With one hoisting gear

Crane movement "slewing" the superstructure

Before initiating this crane movement, the mechanical slewing platform locking (238) must be released.

- Open the slewing gear brake by activating switch (169), upper position.
- Move the hand control lever (244) to the right = "slew to the right".
- Move the hand control lever (244) to the left = "slew to the left".

DANGER: If the slewing movement is performed at an excessive speed, the crane may be damaged.

Before beginning any slewing movements, the crane operator must make sure there are no persons or obstacles in the slewing radius - otherwise, there is an increased risk of accidents.

Before initiating slewing movements, a warning signal (signal horn) must be given.

The speed of the crane movement is controlled by varying lever travel and engine speed.

With the foot pedal (205), the slewing movement can be braked.

In general, the following is valid:

Longer boom	}	slower slewing speed
More load		

DANGER: Slewing movements must always be started and braked gently to prevent the load from swinging and getting out of control.
A swinging load can cause the boom to break off, or can cause the crane to topple over.

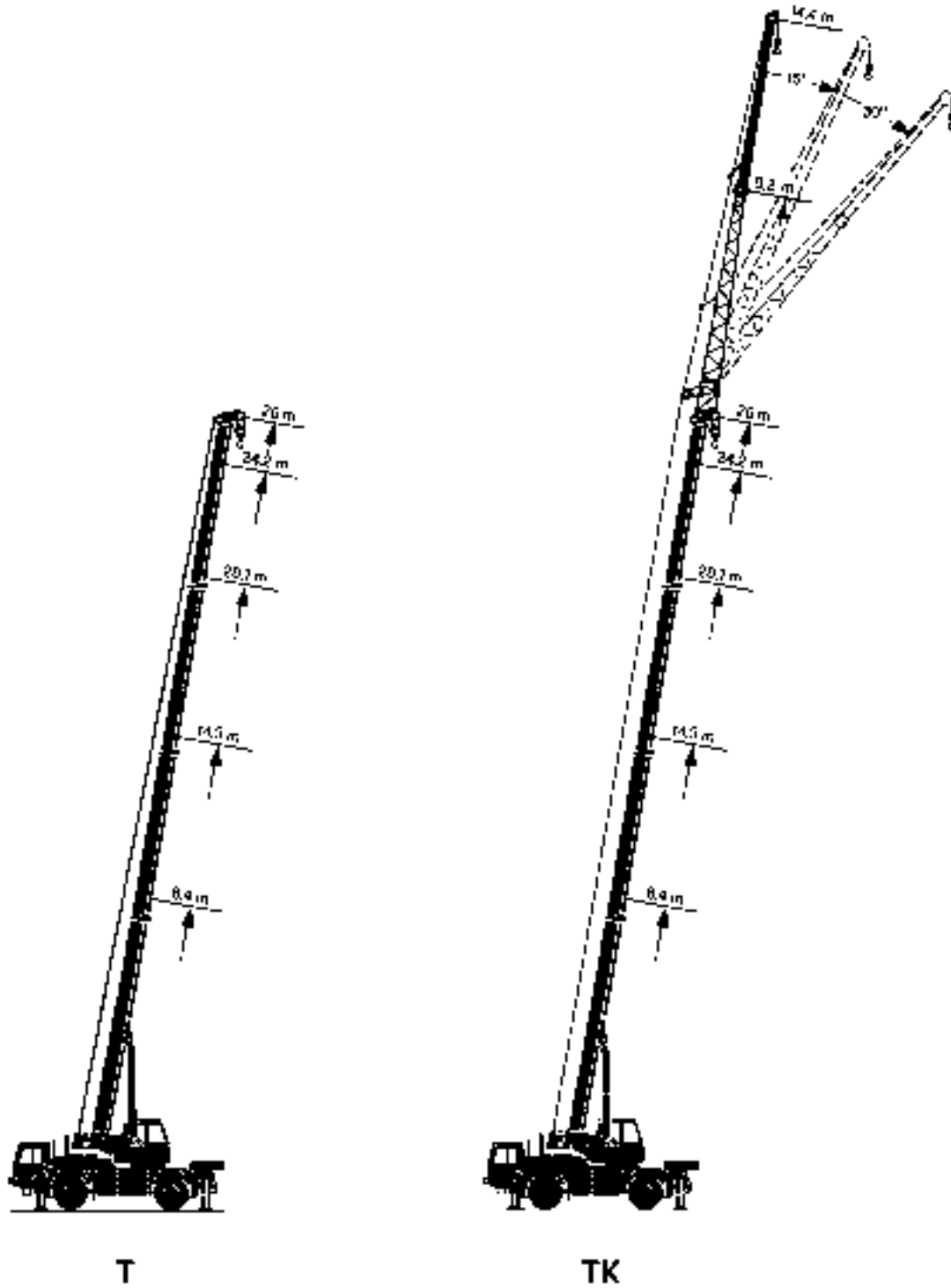

With one hoisting gear

Extended status of the telescopic boom

Telescopic boom length [m]	Extended status of the telescopic boom sections [%]			Code Nr.
	T 1	T 2	T 3	
8,4	0	0	0	★
14,3	33	33	33	★
20,1	66	66	66	★
24,2	90	90	90	★
26,0	100	100	100	★

★ see current load capacity table

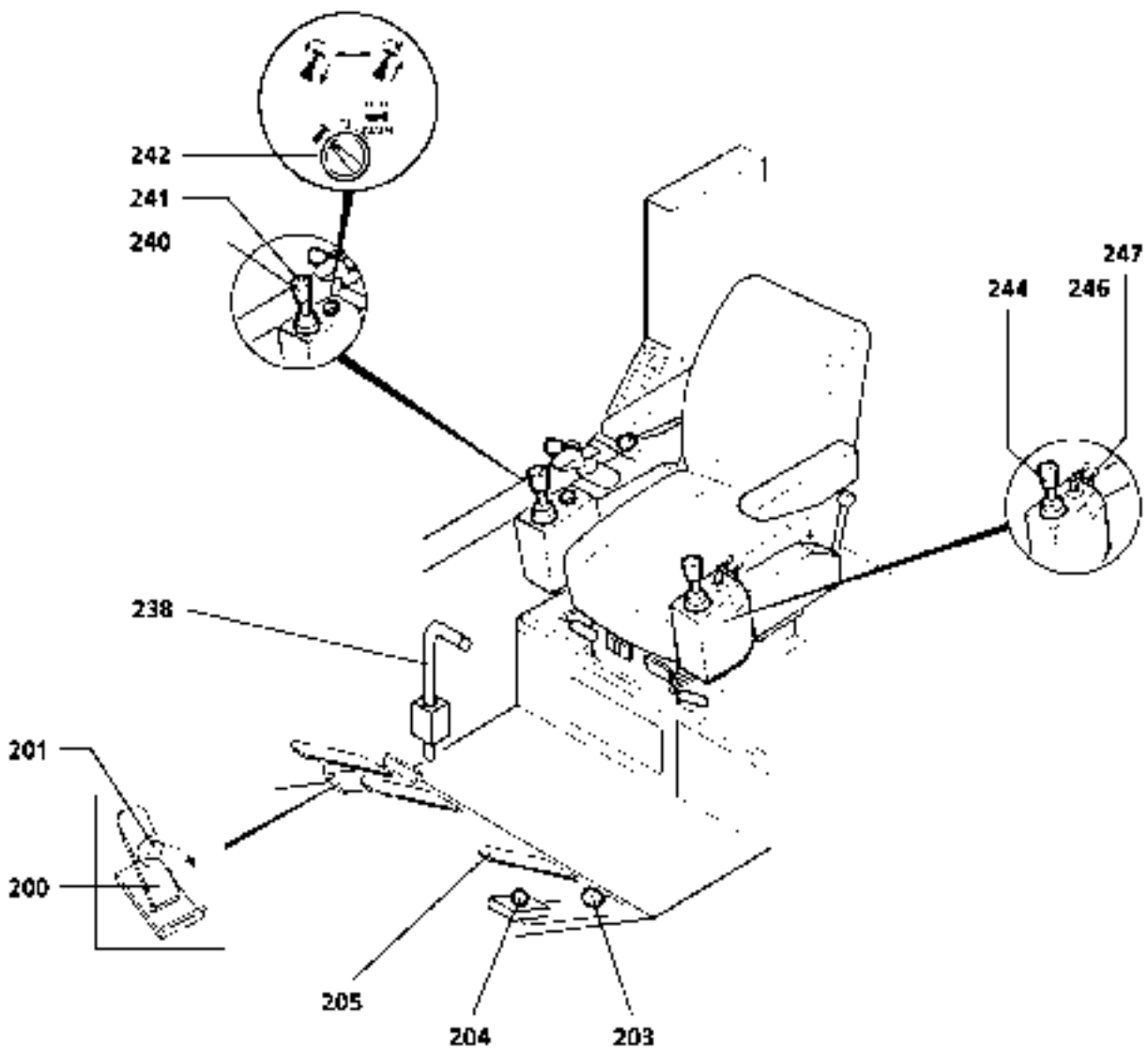
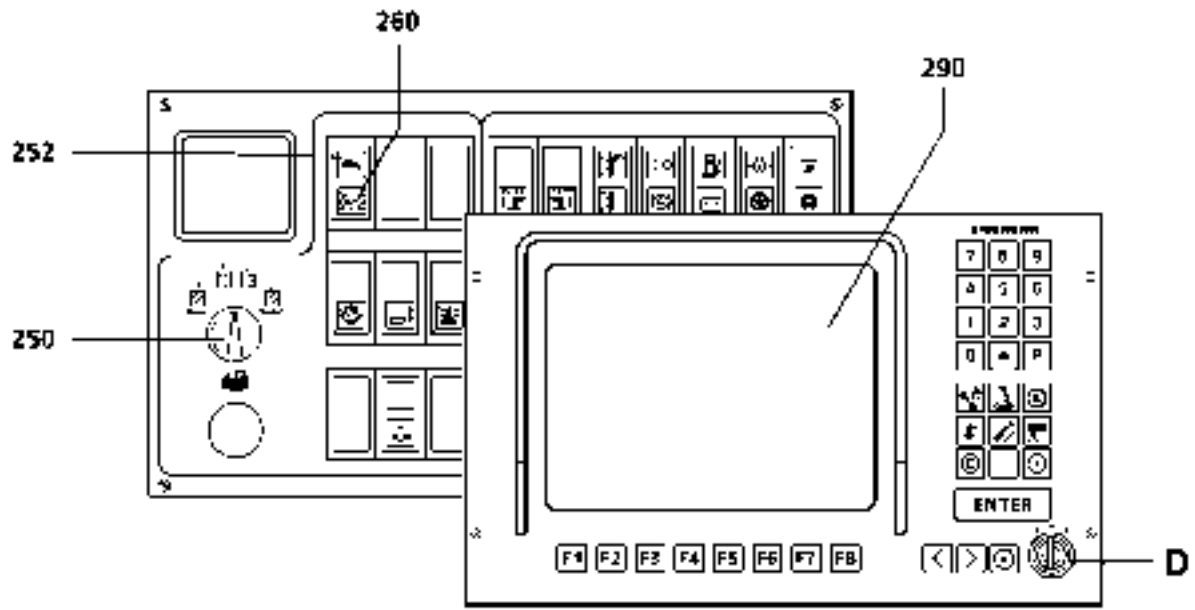

With two hoisting gears**Crane movement "raise / lower" with hoisting gear I**

Move the hand control lever (240) forwards = "lower hoisting gear".

Move the hand control lever (240) to the rear = "raise hoisting gear".

The speed of the crane movement is controlled by varying lever travel and engine speed.

A further increase in speed, for "raise / lower" can be achieved by switching on the high-speed; to do this:

- Press "High-speed" key (241).
- High-speed is now stored, and is indicated by indicator light (252), until the "high-speed" button (241) is pressed again and the indicator light (252) shuts off.
- Initiate lowering or raising movements by moving the manual control lever (240).

DANGER: For 1 - 3 cable reevings, switching to high-speed is prohibited if the crane is loaded to more than 50% of its maximum permissible load capacity at the current working radius.

CAUTION: When spooling out the hoisting cable of hoisting gear I and II, make sure (by observing the winch) that no loose cable is wound in - loose cable can damage the winch cables.

Crane movement "raise / lower" with hoisting gear II

Move the hand control lever (244) forwards = "lower hoisting gear".

Move the hand control lever (244) to the rear = "raise hoisting gear".

The speed of the crane movement is controlled by varying lever travel and engine speed.

A further increase in speed, for "raise / lower" can be achieved by switching on the high-speed; to do this:

- Press "High-speed" key (241).
- High-speed is now stored, and is indicated by indicator light (252), until the "high-speed" button (241) is pressed again and the indicator light (252) shuts off.
- Initiate lowering or raising movements by moving the manual control lever (244).

DANGER: For 1 - 3 cable reevings, switching to high-speed is prohibited if the crane is loaded to more than 50% of its maximum permissible load capacity at the current working radius.

CAUTION: When spooling in and out the hoisting cable of hoisting gear I and II, make sure (by observing the winch) that no loose cable is wound in - loose cable can damage the winch cables.

* Optional

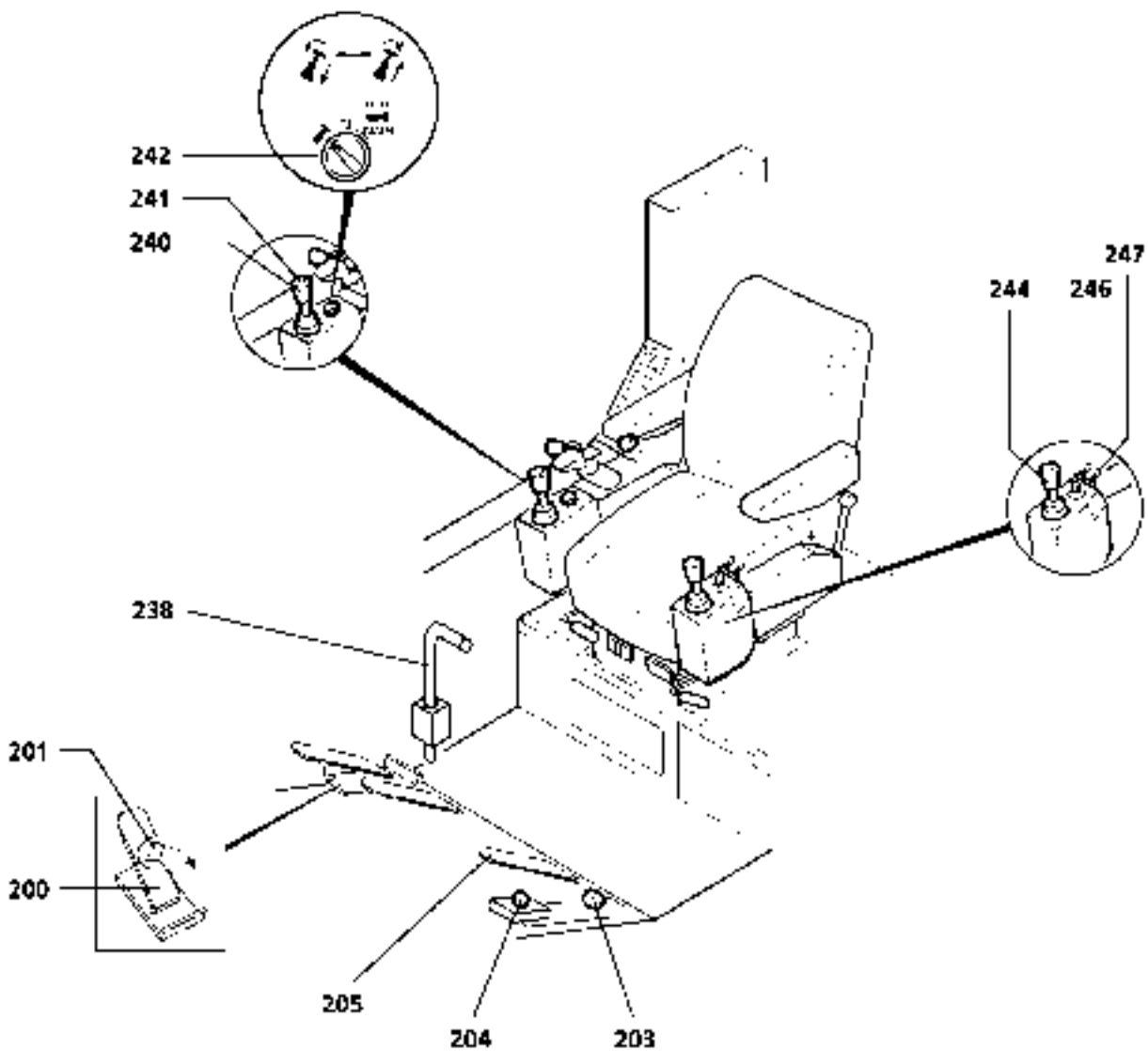
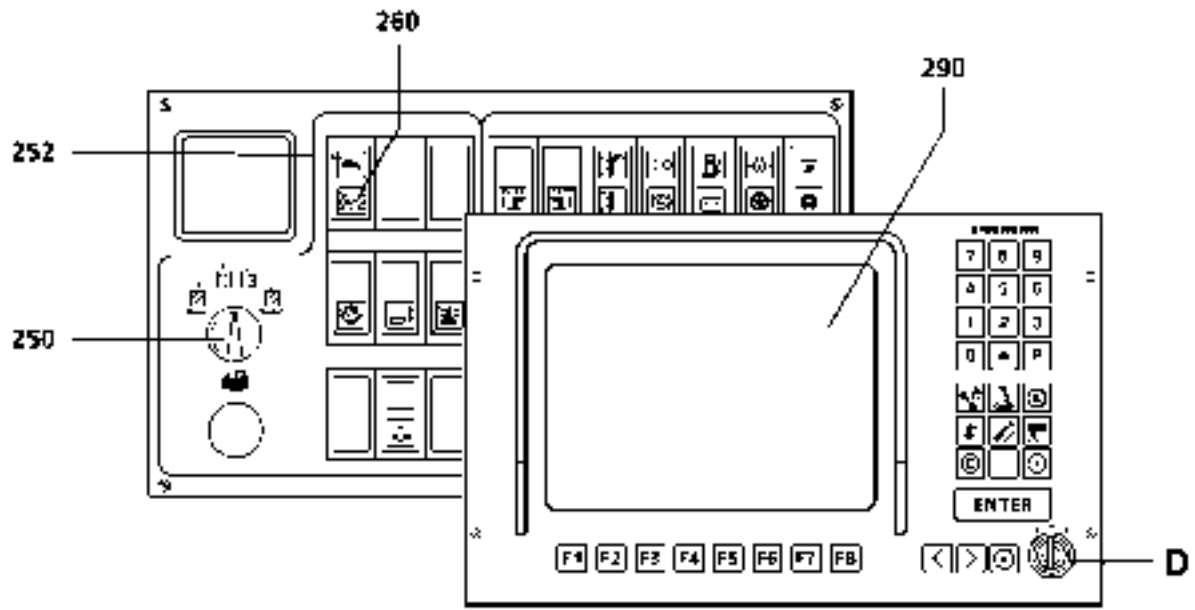

With two hoisting gears ***Crane movement "luffing" the boom**

Via preselector switch (242) select the crane movement "luffing", switch position to the left.

Move the hand control lever (240) to the right = "boom luffs down"

Move the hand control lever (240) to the left = "boom luffs up"

The speed of the crane movement is controlled by varying lever travel and engine speed.

A further increase in speed, for "luffing up" can be achieved by switching on the high-speed; to do this:

- Press "High-speed" key (241).
- High-speed is now stored, and is indicated by indicator light (252), until the "high-speed" button (241) is pressed again and the indicator light (252) shuts off.
- Initiate the boom topping movement by moving the hand control lever (240).

Crane movement "telescoping"

Via preselector switch (242) select the crane movement "telescoping", switch position to the right.

The telescopic sections must be extended to the required length in accordance with the load capacity table by activating the manual control lever (240).

Each extension is assigned a 2-place code number.

This code number is taken from the current operational load capacity table and is input via the LICCON keypad.

Note: Refer to the separate "LICCON" operating instructions.

Move the hand control lever (240) forwards = "extend telescope".

Move the hand control lever (240) to the rear = "retract telescope".

The speed of the crane movement is controlled by varying lever travel and engine speed.

The speed of the crane movement "extend telescope" can be increased by switching on the high-speed; to do this:

- Press "High-speed" key (241).
- High-speed is now stored, and is indicated by indicator light (252), until the "high-speed" button (241) is pressed again and the indicator light (252) shuts off.
- Initiate the telescoping out movement by moving the hand control lever (240).

CAUTION: In normal operations, the telescopic boom is extended without a load to the required length, and only then loaded.

However, it is possible to extend the telescopic boom under partial load.

This partial load is dependent on the lubrication of the bearing pads as well as the available useable length of the boom.

The maximum permissible partial load is limited by the pressure setting on the pressure relief valve of the telescope cylinder.

The partial load indicated on the LICCON must never be exceeded!

* Optional

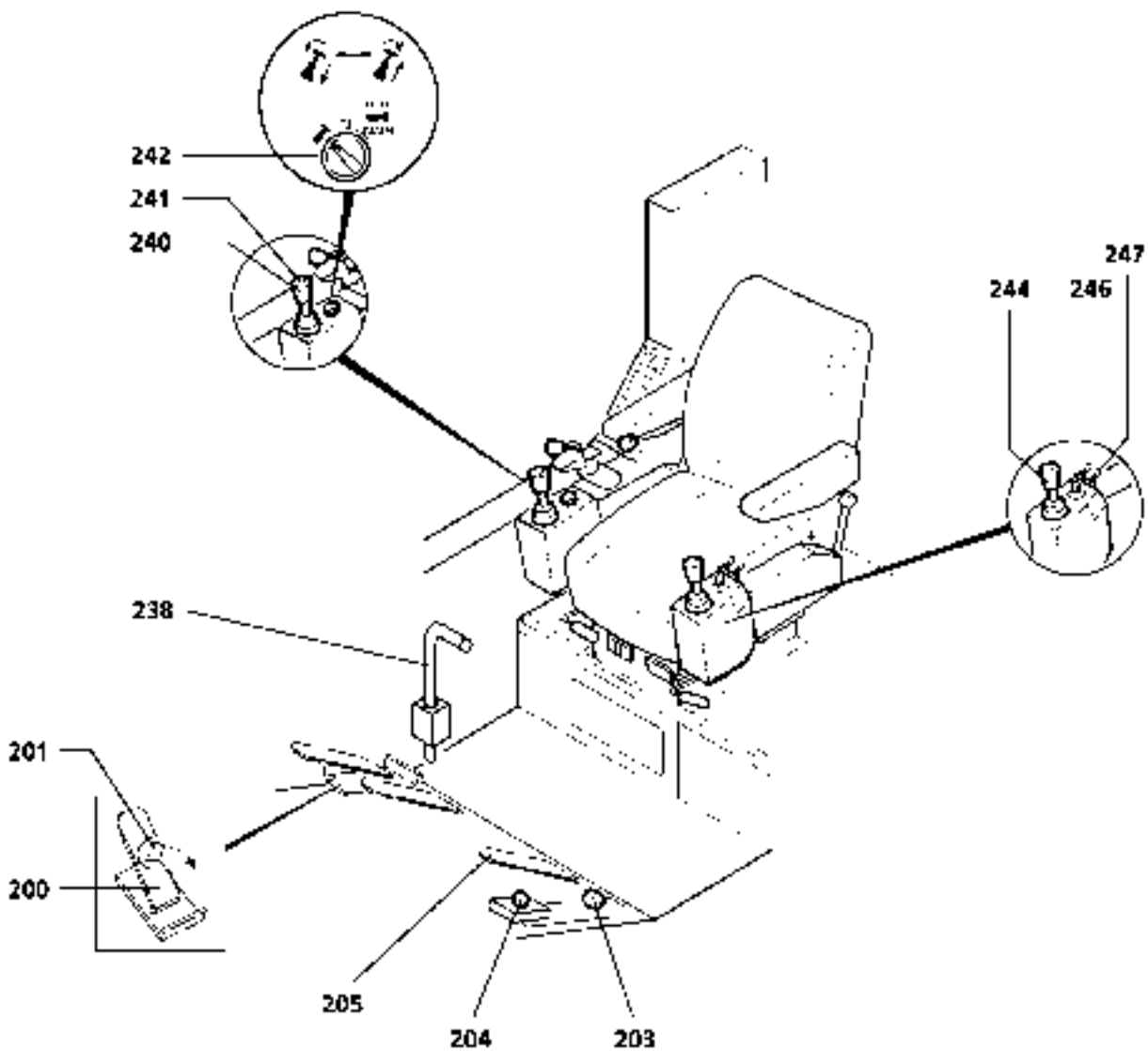
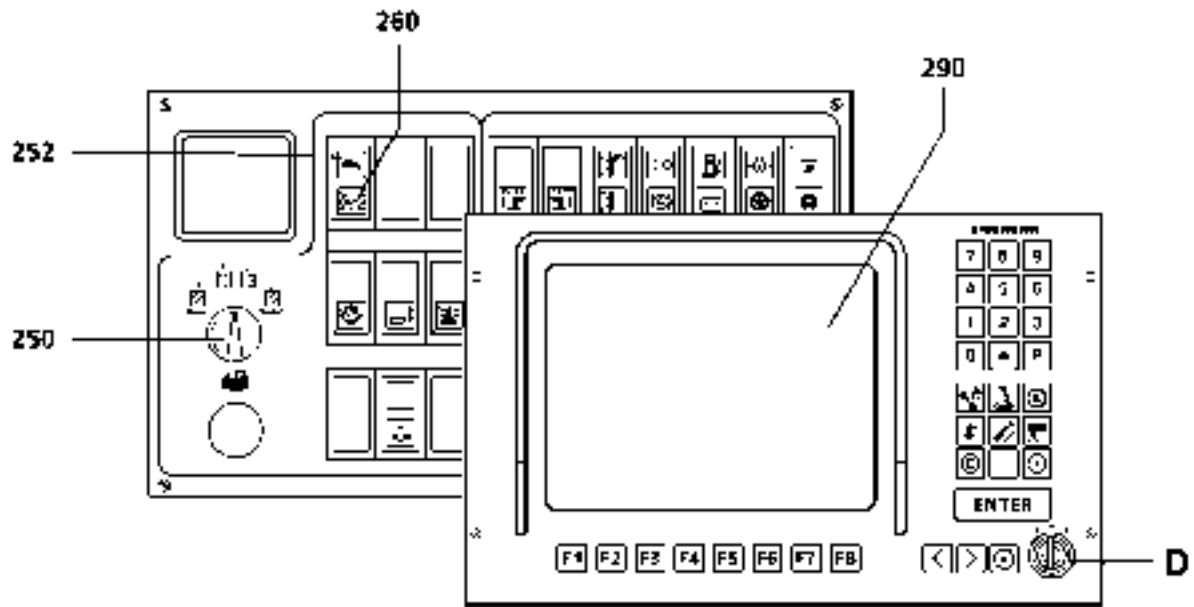

With two hoisting gears ***Crane movement "slewing" the superstructure**

Before initiating this crane movement, the mechanical slewing platform locking (238) must be released.

- Open the slewing gear brake by activating switch (247), upper position.
- Move the hand control lever (244) to the right = "slew to the right".
- Move the hand control lever (244) to the left = "slew to the left".

DANGER: If the slewing movement is performed at an excessive speed, the crane may be damaged.

Before beginning any slewing movements, the crane operator must make sure there are no persons or obstacles in the slewing radius - otherwise, there is an increased risk of accidents.

Before initiating slewing movements, a warning signal (signal horn) must be given.

The speed of the crane movement is controlled by varying lever travel and engine speed.

With the foot pedal (205), the slewing movement can be braked.

In general, the following is valid:

Longer boom	}	slower slewing speed
More load		

DANGER: Slewing movements must always be started and braked gently to prevent the load from swinging and getting out of control.
A swinging load can cause the boom to break off, or can cause the crane to topple over.

* Optional

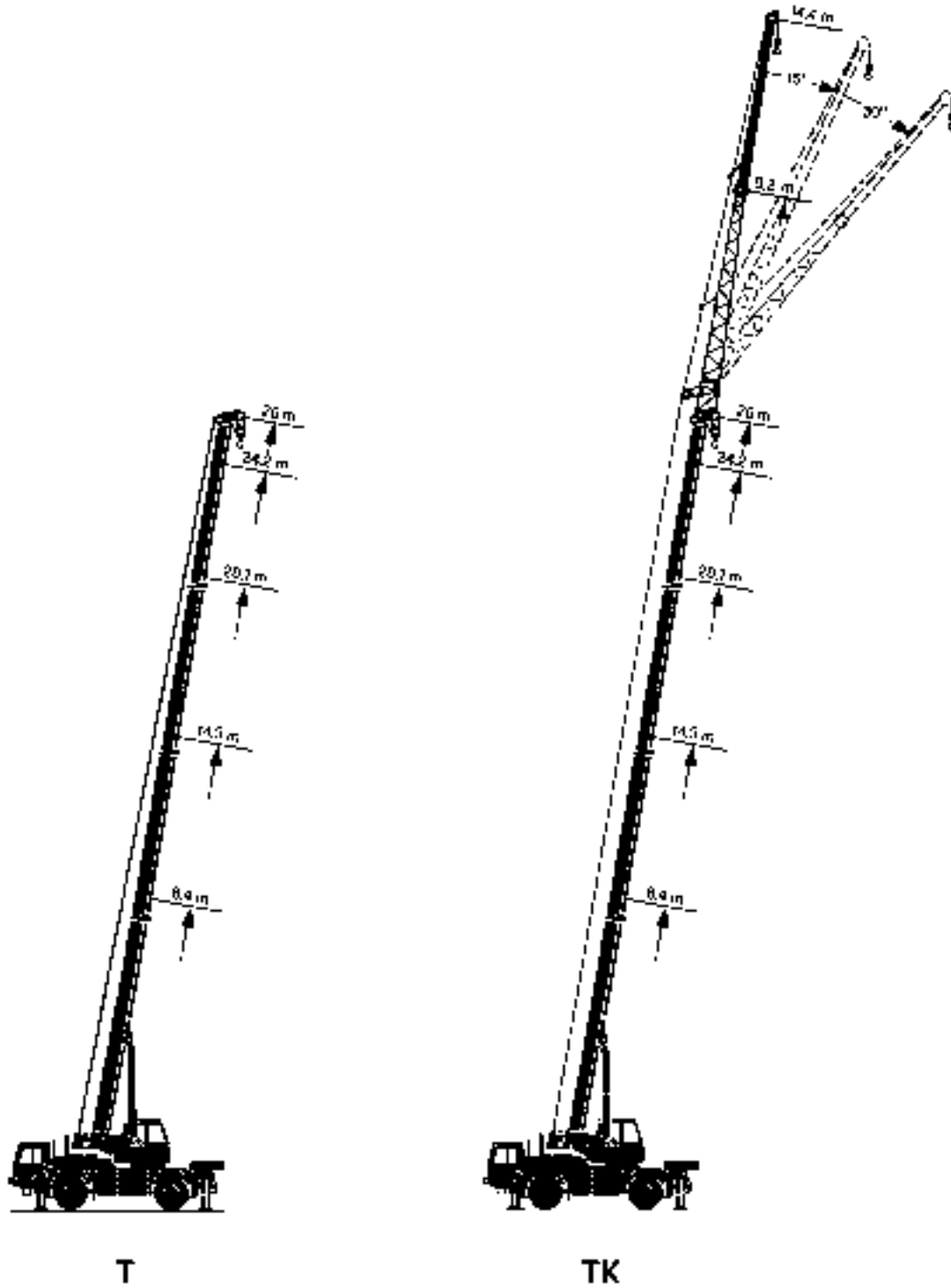

With two hoisting gears *

Extended status of the telescopic boom

Telescopic boom length [m]	Extended status of the telescopic boom sections [%]			Code Nr.
	T 1	T 2	T 3	
8,4	0	0	0	★
14,3	33	33	33	★
20,1	66	66	66	★
24,2	90	90	90	★
26,0	100	100	100	★

★ see current load capacity table

* Optional

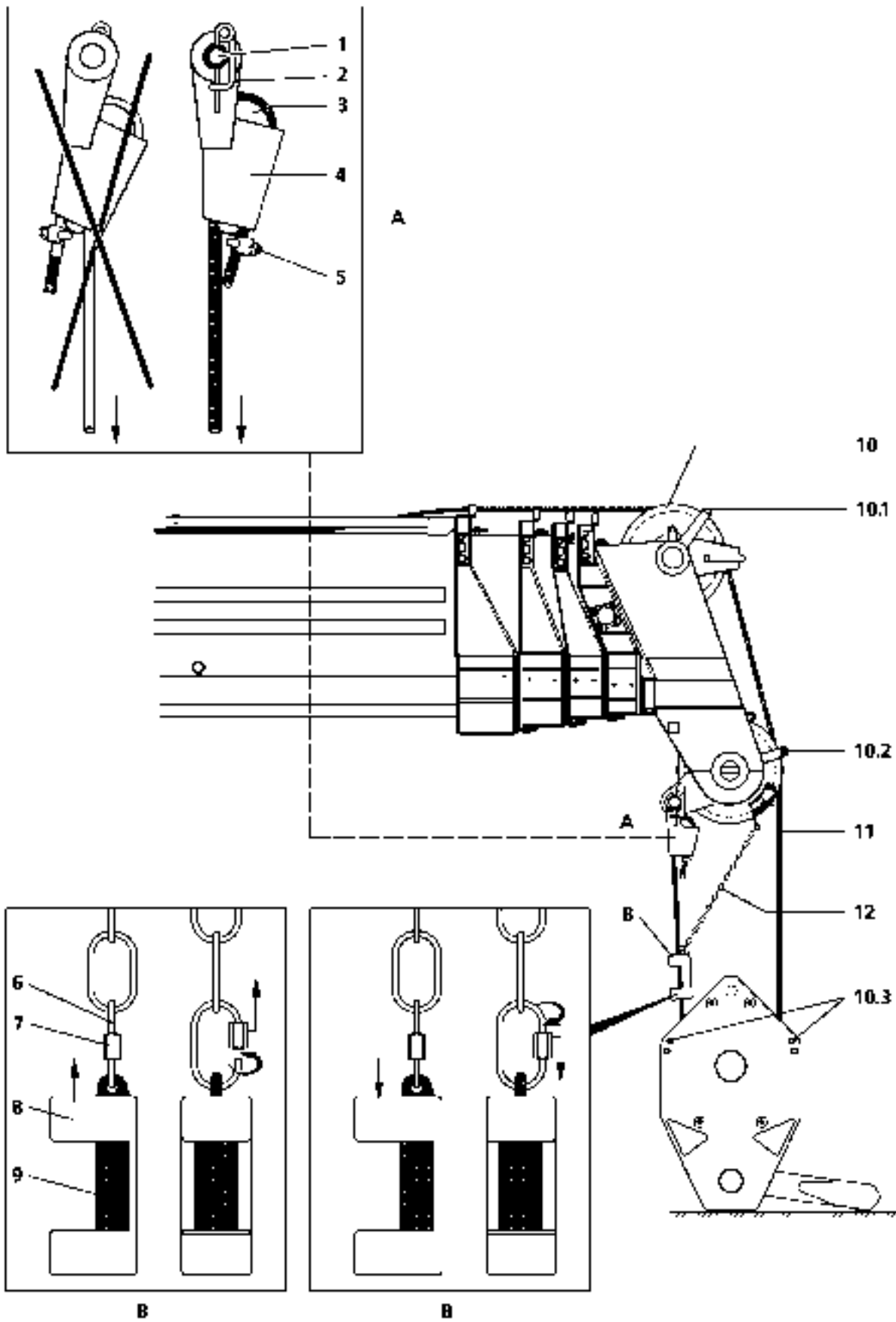

Reeving the hook block

Requirements:

- The crane is properly supported and aligned horizontally,
- an assistant is present to guide the cable.

Assembly sequence:

- Loosen the spring keeper and pull both of the cable retaining axles (10.1 and 10.2) on the pulley head.
- Place the hook block needed under the pulley head of the telescoping boom.
- Remove the locks (spring keepers) on the cable retainer axles (10.3) and pull out the cable retainer axles.
- Start the crane engine.
- Lead the hoisting cable over the telescoping boom to the pulley head.

Note: While the assistant is guiding the hoisting cable to the pulley head, the crane driver has to operate the winch. This should be done in a manner so that no slack cable forms on the cable drum.

DANGER: **This procedure must be performed from a secure place. Leading the cable on the telescoping boom to the pulley head is unavoidable; use utmost caution when walking on the telescoping boom. There is danger of an accident occurring due to faulty operation of the crane functions or slipping on the telescoping boom.**

- Lay the hoisting cable over the upper cable pulley (10) and reeve in the hoisting cable between the pulley head and the hook block according to the reeving plan for the current load capacity table.
- Pull the end of the cable through the cable joint (Fig. A, item 4).
- Lay the end of the cable around the clamp cleat (3) and pull the cable joint (4) over it.
- Fasten on the clamp cleat (5).
- Pull off the spring keeper (2) and take out the bolts (1).
- Bolt the cable joint (A) onto the pulley head or the hook block, according to the reeving, and secure it with the spring keeper.
- Put the cable retainers (10.1, 10.2, and 10.3) back in place and secure them with spring keepers.

Note: The bolts (1) must be placed from the inside to the outside, and secured on the outside, in order to prevent the hoisting cable from rubbing on the bolts or on the spring keeper (2).

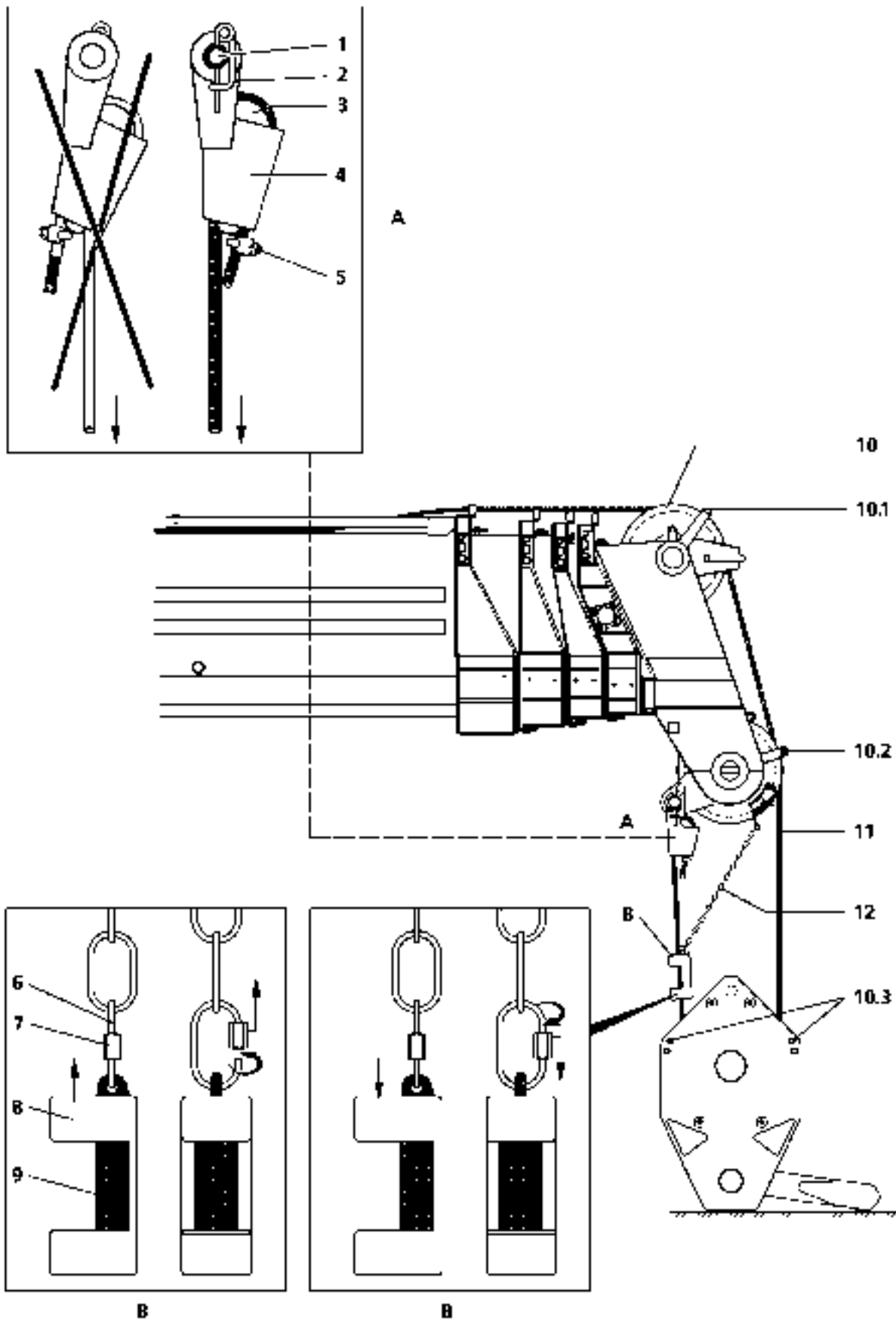

Mount the hoist limit switch weight

- Open the chain lock (Fig. b, item 6) on the hoist limit switch weight (B).
- Loosen the hexagonal cap nut (7) with a 13mm open-end wrench and unscrew it by hand.
- Hang out the hoist limit switch weight (B).

C A U T I O N : **The hoist limit switch weight (B) consists of two parts, one inside the other (8,9).
When hanging it in and out, make sure the two parts do not slide out of each other
causing the weight (8) to fall.
Danger of foot injury.**

- Place the weight (8) on the hoisting cable and hold it there,
- using the other hand, guide the carrying section (9) under behind the hoisting cable, under the weight (8).

Note: When multiple hoisting cable reeving is used, the hoist limit switch weight (B) must always be placed around the "**standing cable**", i.e. around the cable with the cable fastening point on it.

- Push the weight (8) over the carrying section (9).
- Hang the hoist limit switch weight in the chain lock (6) again.
- Screw down the cap nut (7) and tighten it hand-tight with a 13mm open-end wrench.

D A N G E R : **The chain lock (6) is also the fastener for the weight (8).
Other parts such as shackles or spring hooks may not be substituted.
The chain lock (6) must always be hung so that the cap nut (7) is above, i.e. on the
chain, (12) and the chain lock is closed by turning the cap nut (7) downwards.
This ensures that the cap nut (7) cannot loosen by itself, opening the chain lock.**

Visual check:: Is the chain lock (6) completely closed?
Is the hoist limit switch weight (B) mounted on the "standing cable"?

- Enter and/or check the number of reeves in the overload safety device.

D A N G E R : **The crane operator must ensure again that the reeving is done properly and that the
overload safety device is properly set. Improper reeving or improper input can lead
to accidents.**

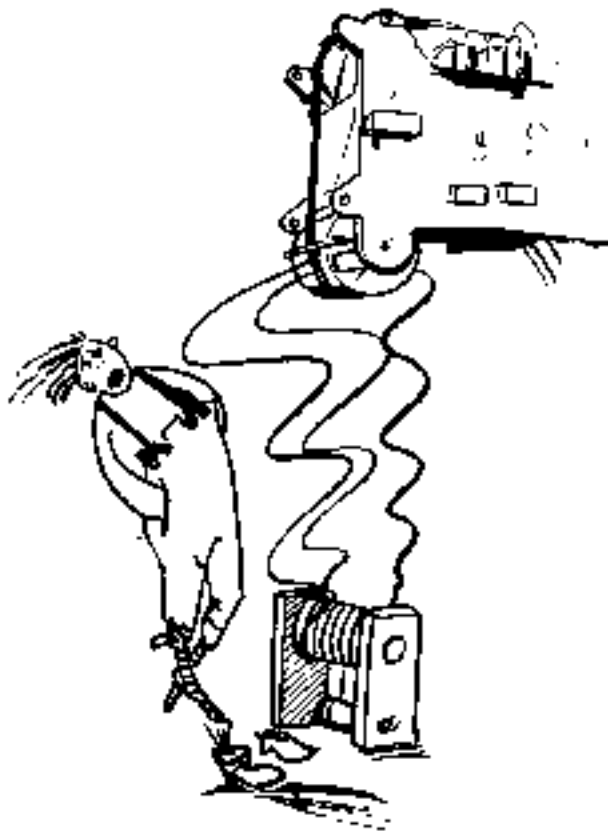

Unreeving the hook block**Assembly sequence:**

- Lower the hook block to the ground and check to make sure it is standing in a stable position.
- Unpin the cable joint and loosen the cable clamp.
- Slowly rewind the hoisting cable.

D A N G E R: **There must be no persons in the area around the hook block. During rewinding, the cable can lash out like a whip. It must be ensured that there is no loose cable on the winch.**

- Attach the hoisting cable with the cable joint onto the pulley head, or rewind the complete hoisting cable onto the winch.

C A U T I O N: **Always rewind the hoisting cable so that there is at least 2 m remaining - never rewind the cable end onto the winch!**

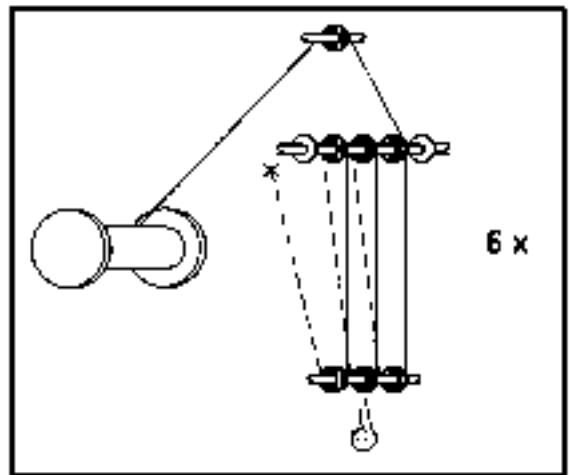
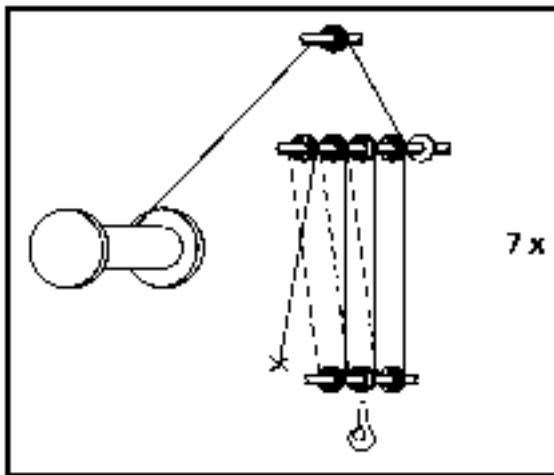
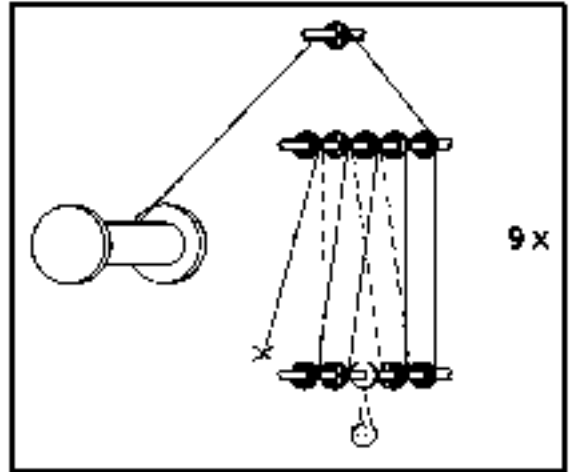
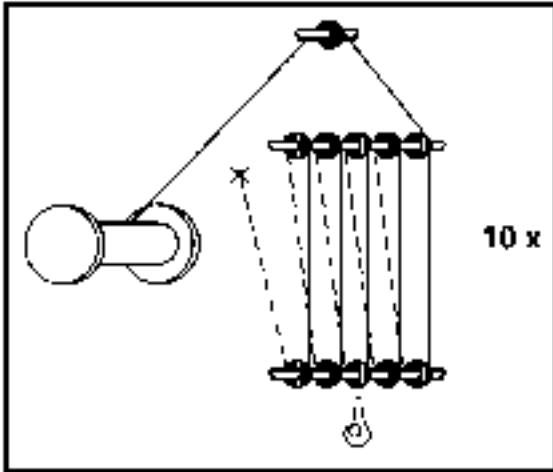

Reeving plans, cable socket on the side of the pulley head

"Normal" reeving for:

5-roller hook block	10 × reeving
3-roller hook block	6 × reeving
1-roller hook block	2 × reeving

T**Reeving plans, cable socket on the side of the hook block**

"Normal" reeving for:

5-roller hook block	9 × reeving
3-roller hook block	7 × reeving
1-roller hook block	3 × reeving

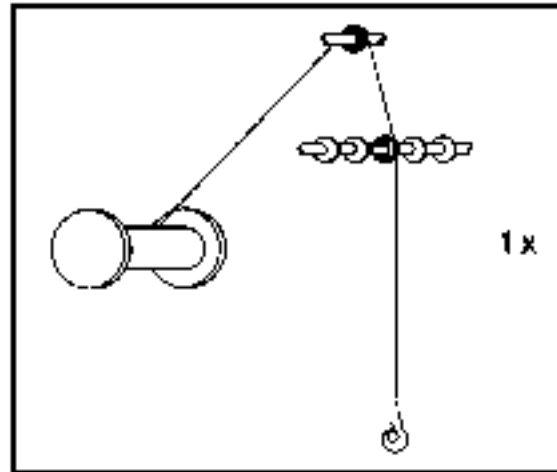
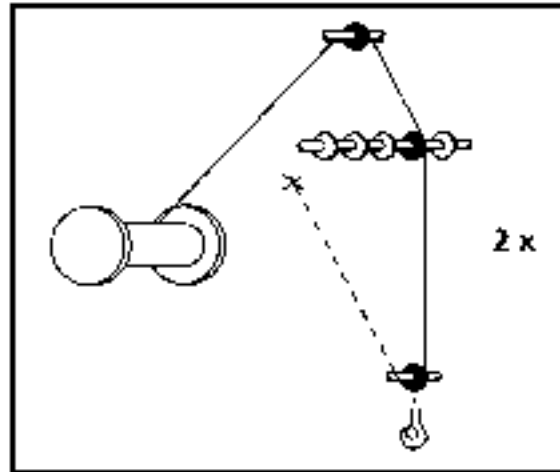
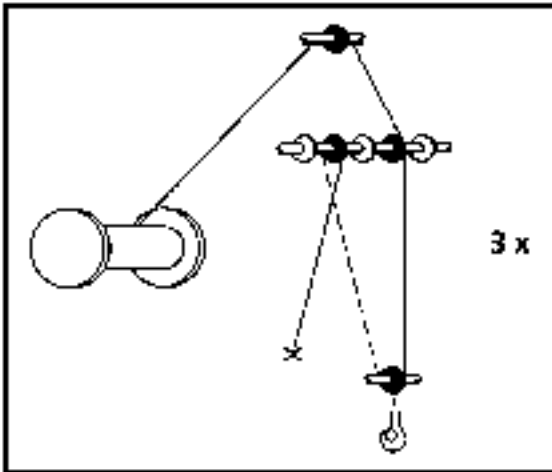

Reeving plans, cable socket on the side of the pulley head

"Normal" reeving for:

5-roller hook block	10 × reeving
3-roller hook block	6 × reeving
1-roller hook block	2 × reeving

T**Reeving plans, cable socket on the side of the hook block**

"Normal" reeving for:

5-roller hook block	9 × reeving
3-roller hook block	7 × reeving
1-roller hook block	3 × reeving

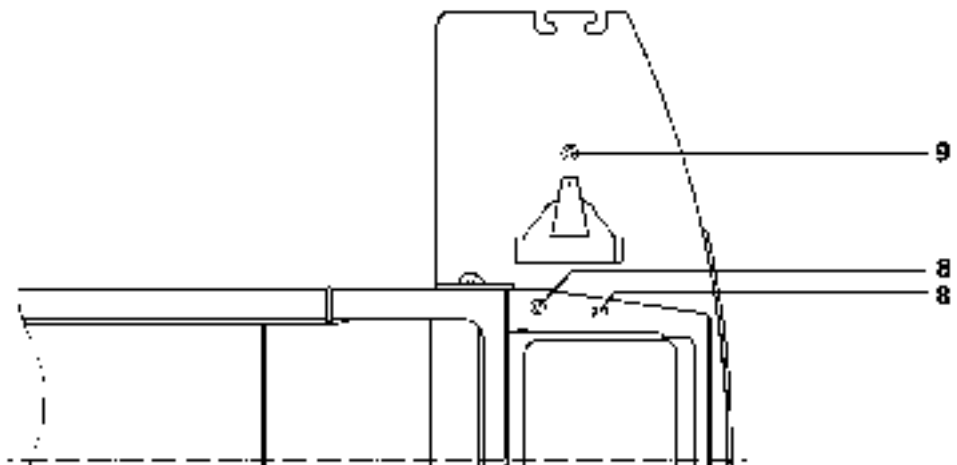
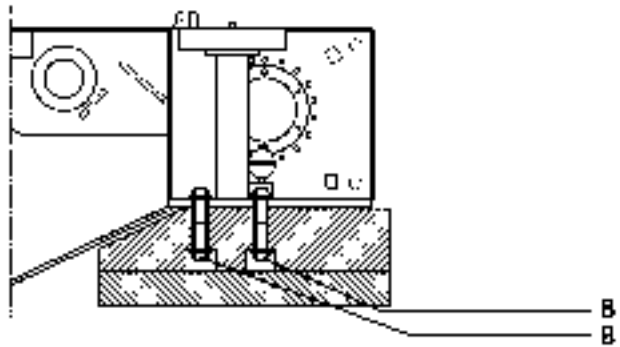
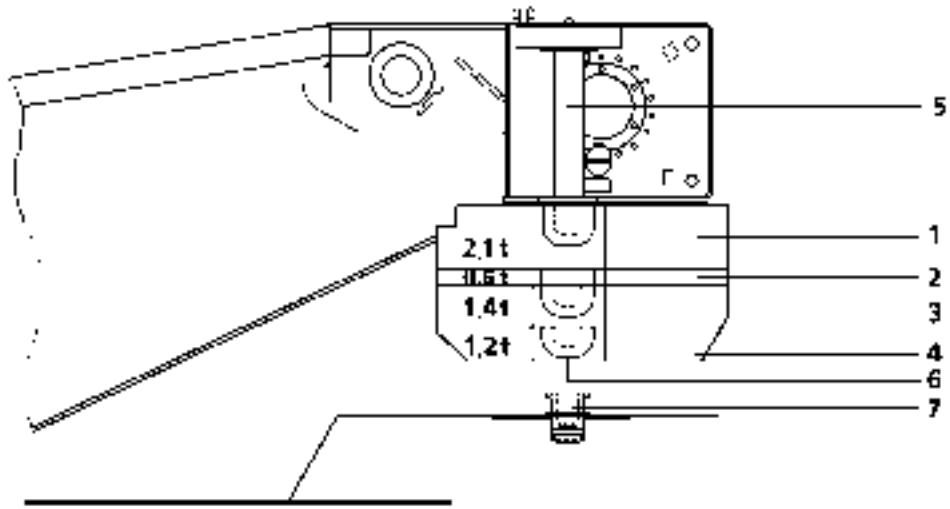

Ballast slabs

The ballast slabs are marked with their own weights.

DANGER: The mounting of the ballast slabs must correspond to the information given in the load capacity table - otherwise, there is the danger of accidents.

The following combinations are possible:

ballast	without hoisting gear II		with hoisting gear II	
	combination	individual weight	combination	individual weight
2,1 t	slab 1	2,1 t	slab 1	2,1 t
2,7 t	slab 1 slab 2	2,1 t 0,6 t	slab 1 slab 2	2,1 t 0,6 t
3,3 t	slab 1 slab 4	2,1 t 1,2 t	slab 1 slab 4	2,1 t 1,2 t
5,3 t	slab 1 slab 2 slab 3 slab 4	2,1 t 0,6 t 1,4 t 1,2 t	slab 1 slab 2 slab 3 slab 4	2,1 t 0,6 t 1,4 t 1,2 t

CAUTION: When hoist gear 2 is installed, the rear axle load is increased by 750 kg.

Note: Ballast plate (4) is held by the locking mechanisms of both ballasting cylinders (5).

DANGER: The 1.4 ton counterweight (3) must be mounted with one M 24 x 160 screw (6) to the 1.2 ton counterweight (4), because only the lower counterweight can be locked to the mount (7) on the vehicle.
The 2.1 ton counterweight (1) must be mounted with four M 24 x 130 screws (8) to the slewing platform.
The 0.6 ton counterweight (2) must be mounted with two M 30 x 140 screws (9) to the 2.1 ton counterweight (1).

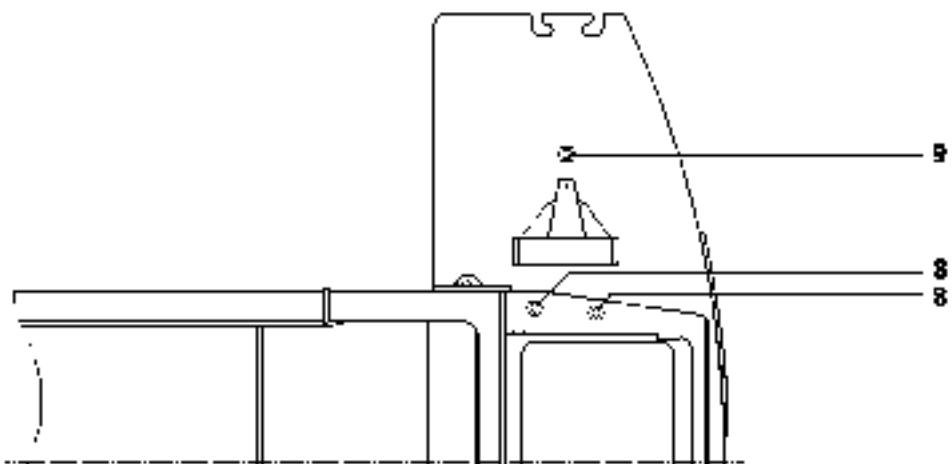
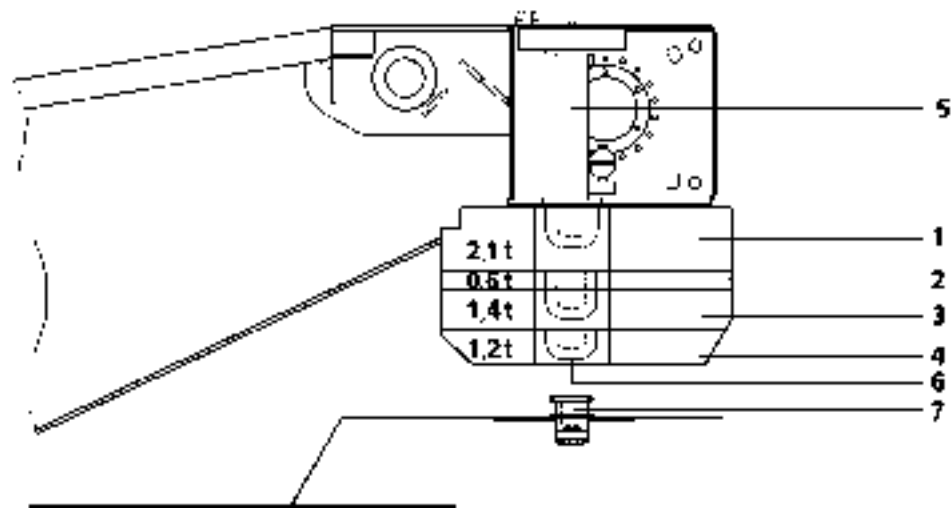
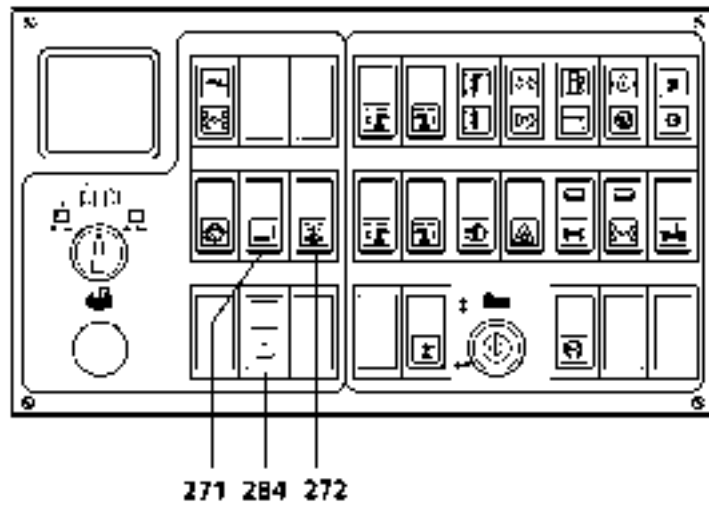

Mounting / Dismounting**Requirements:**

The crane must be correctly suspended and horizontally aligned.

CAUTION: The ballasting cylinder (5) must be completely retracted - otherwise, there is the danger of collision.

DANGER: There must be no persons or obstacles in the slewing radius.

When the boom is in a steep position for which there is no load capacity in the load capacity table, there is a danger of the crane tipping over in the direction of the ballast when the slewing platform is rotated.

This is especially dangerous

- at reduced support bases or
- if supported with the sliding arms retracted

Mounting sequence

Start the driving and crane engine

Set the load torque limiter according to the load capacity table and the mounted ballast.

Disengage slewing platform.

DANGER: Before the boom can be raised from its transport rest, the crane must be supported in accordance with the load capacity table and the "LICCON" overload safety device must be set corresponding to the appropriate and valid load capacity table. If this is not carried out, there is the danger of the crane tipping over.

Note: The base plate (4) must always be the first slab placed on the vehicle frame, since it is the carrier plate for all other slabs.

Rotate the crane superstructure (telescopic boom in direction of travel to the rear) until the ballasting cylinders (5) are above the ballast slab (4) or the the ballast slabs (3) +(4).

CAUTION: When rotating for this procedure, the ballasting cylinder must be completely retracted - otherwise there is the danger of collision with the ballast slabs stacked on the vehicle.

DANGER: There must be no persons or obstacles in the slewing radius.

Taking on ballast

Keep button (271) depressed until the green indicator lamp in the switch comes on, ballasting cylinders (5) extended into the recesses of the ballast.

Keep button (272) depressed until the red indicator lamp in the switch goes out, ballasting cylinders (5) are engaged with the ballast.

Keep button (271) pressed "up" until the green indicator lamp in the switch comes on, ballasting cylinders are retracted and the ballast raised to the stop on the ballast slab).

DANGER: If button (272) is pressed and the red indicator lamp remains on, then neither ballasting cylinder is engaged / released and there must be NO ballast movements (ballast raise/lower) with button (271).

Adjust the LICCON overload safety device according to the load capacity chart and the installed counterweight.

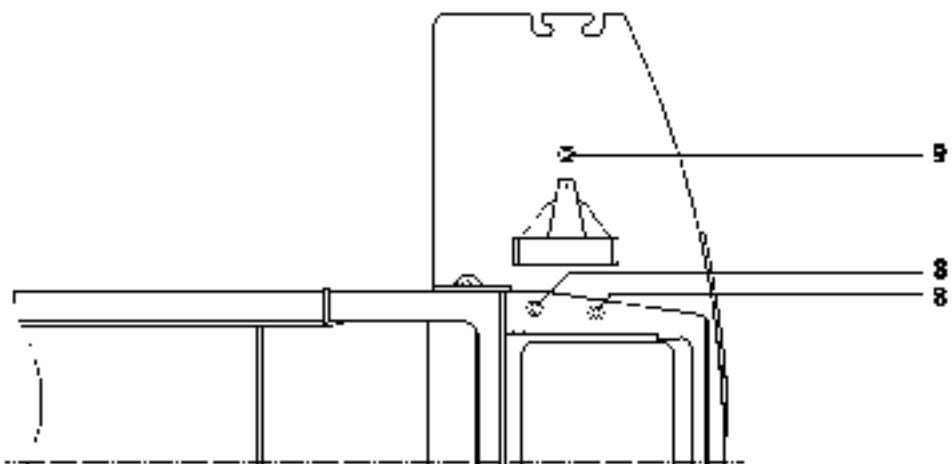
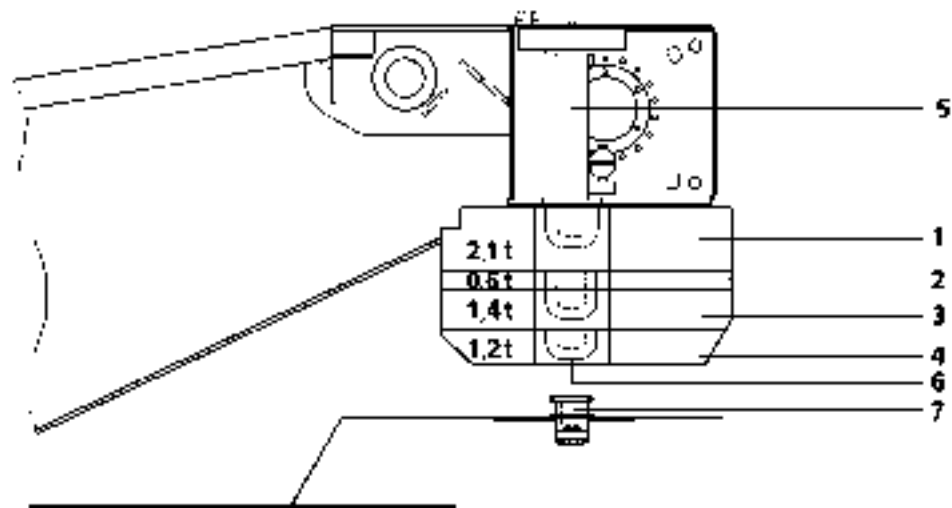
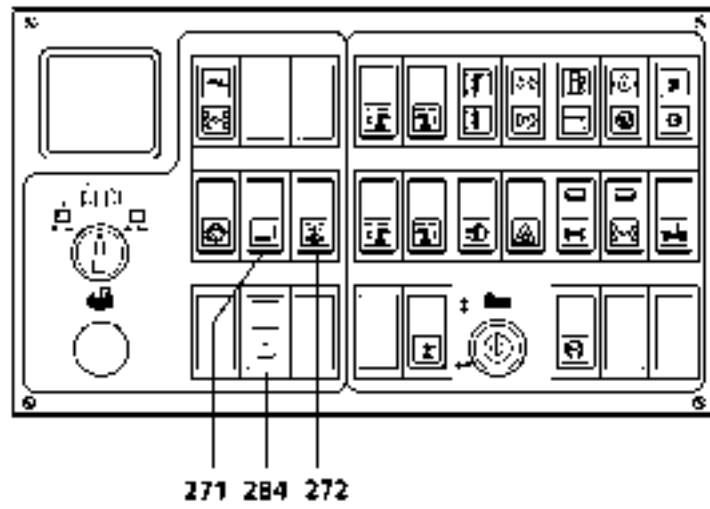

Removing ballast

Rotate the crane superstructure (telescopic boom in direction of travel to the rear) until the ballast is above the receiver (7) on the vehicle.

DANGER: Before beginning any slewing movements or lowering any ballast, the crane operator must make sure there are no obstacles in the slewing range or persons in the danger zone!

Lock crane superstructure to crane chassis with lynch pin (238).
Indicator lamp (284) comes on.
Lower the ballast slowly.

CAUTION: The superstructure must be locked to the chassis, so that the ballast can be placed on the centerings provided and fastened.

DANGER: When placing the ballast on the vehicle frame there must be no foreign bodies under the ballast.
If this is not the case, the ballast cannot be properly locked and a proper securing to the vehicle is not ensured.

Keep button (271) pressed down until the green indicator lamp comes on in the switch, the ballast is in the ballast rest.

Keep button (272) pressed "up" until the red indicator lamp in the switch goes out, the ballasting cylinders (5) are released; the ballast is automatically locked in the ballast rest (7) simultaneously.

Keep button (271) pressed "up" until the green indicator lamp in the switch comes on, the ballasting cylinders (5) are retracted.

Lowering ballast slab (1)

DANGER: The four hex screws (8) of slab (1) may only be removed if ballast slab (1) is held above the ballasting cylinders (5) by ballast slab (4) or an auxiliary crane.

Lowering ballast slab (2)

DANGER: Both hex screws (9) of slab (2) may only be removed if ballast slab (2) is held above the ballasting cylinders (5) by ballast slab (4) or an auxiliary crane.

Note: When transporting, the ballast slabs must be distributed as described in Chap. 3.04, "DRIVING ON PUBLIC ROADS".

DANGER: Before every trip, make sure to visually check the counterweight slabs for damage. Damaged counterweight slabs must be replaced.
Fix any distortions on the mounting bracket first before placing the counterweight slabs.

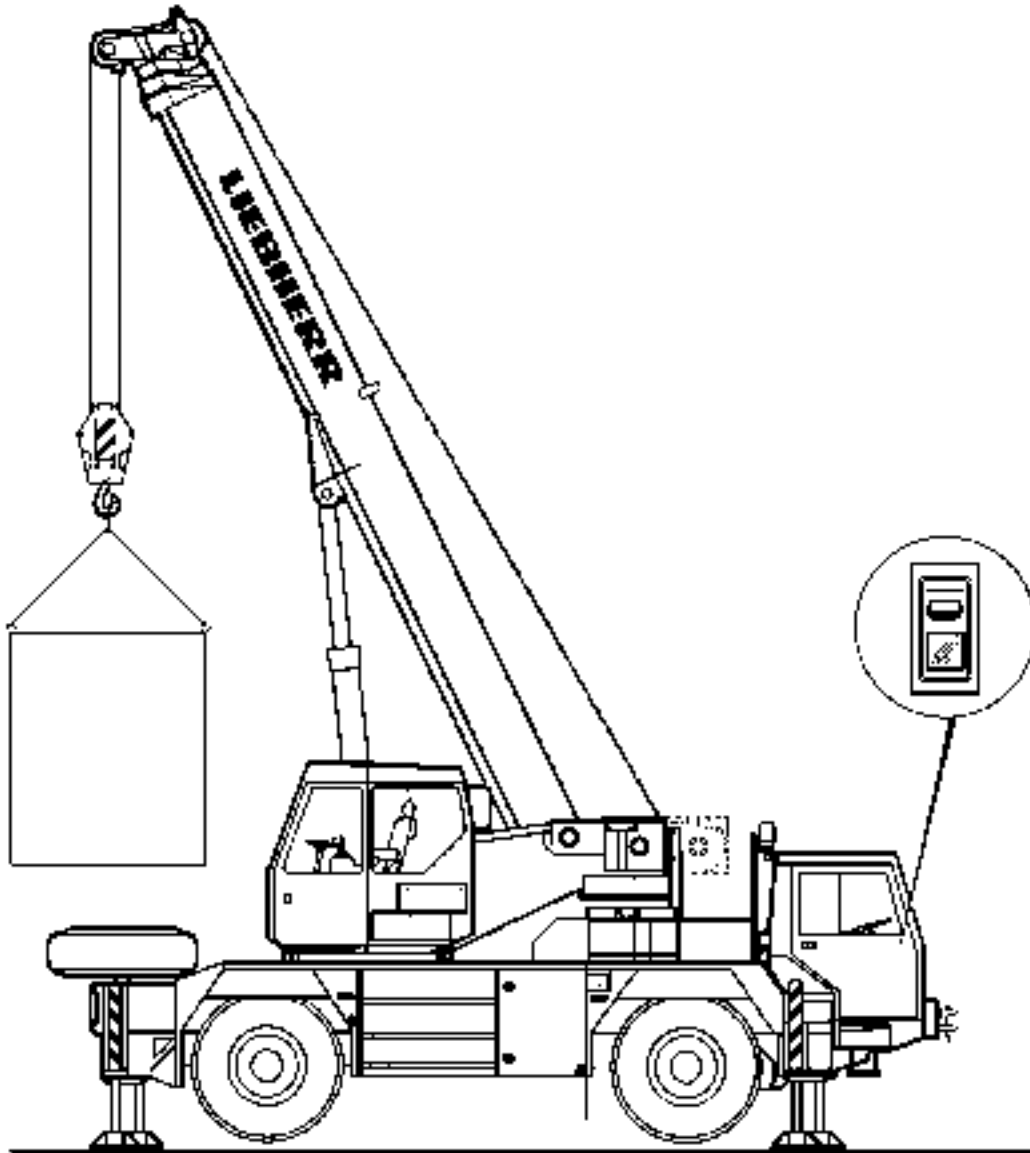

Safety-technical notes for working with a load

Note: Refer to the safety-technical notes in Chap. 2.04!

- Always maintain the maximum load as specified in the load capacity table.
- Always maintain the working radius as specified in the load capacity table.

D A N G E R : When the boom is in a steep position for which there is no load capacity in the load capacity table, there is a danger of the crane tipping over in the direction of the ballast when the slewing platform is rotated.

This is especially dangerous

- at reduced support bases or
- if supported with the sliding arms retracted

Operating the crane at a smaller working radius than that specified in the load capacity table is not permitted, regardless of whether there is a load on the hook or not - doing so increases the risk of accidents.

- Always maintain the number of reevings corresponding to the maximum load capacity as specified in the load capacity table.

D A N G E R : If this is not done, the cable could snap, causing serious damage or injury!

- The load must be prevented from swinging by slowly initiating crane movements and carefully braking.
- If the lowest layer of a winch drum is reached, an observer must make sure that there is always at least 3 coils remaining on the winch drum.

D A N G E R : Not following this rule can lead to serious accidents!

- Hook blocks larger than those required to hoist the maximum load as specified in the load capacity table are not permitted.

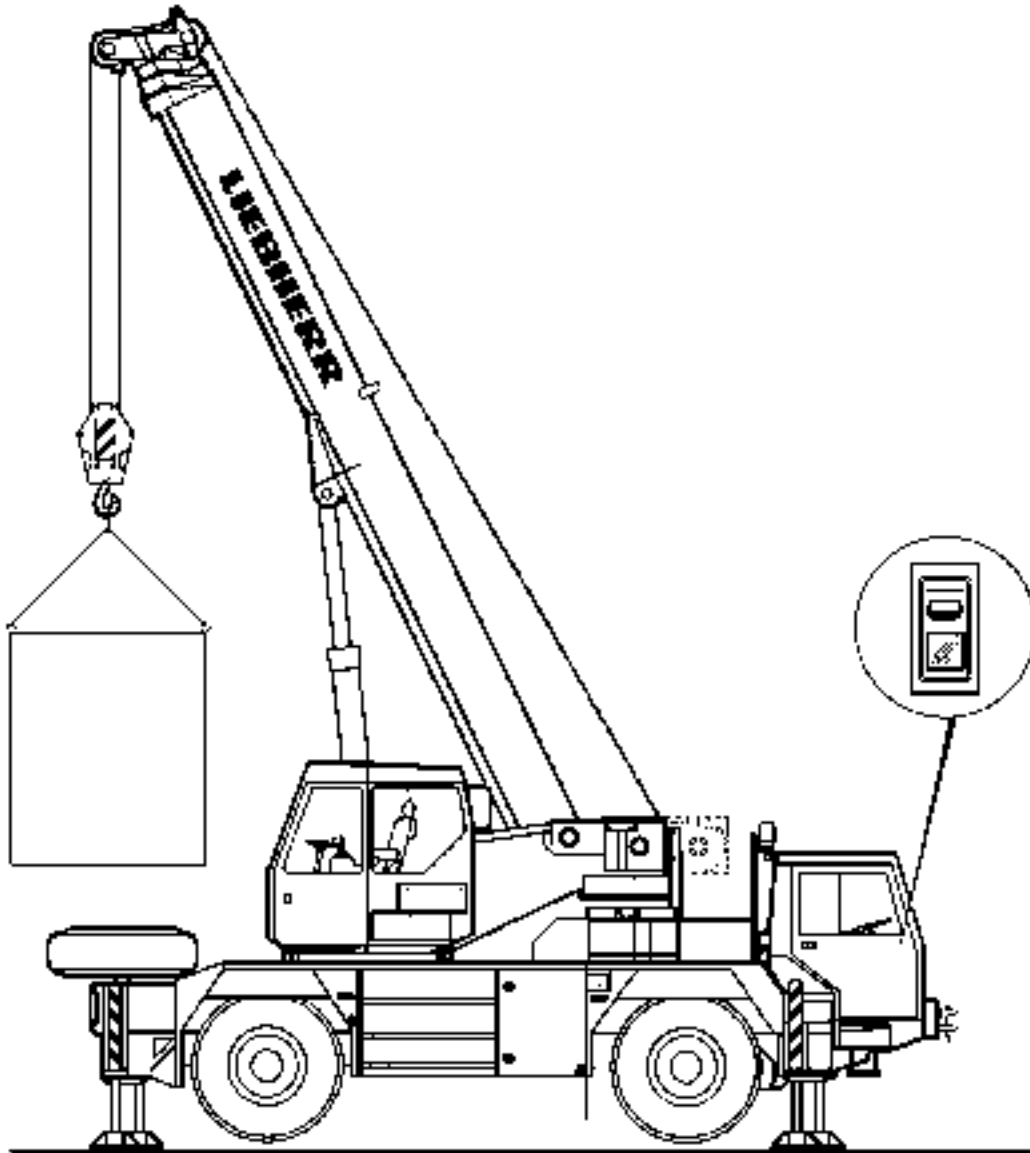

Inspection

Before beginning any crane operations, the crane operator must carry out a thorough inspection routine and make sure that the operational safety of the crane is ensured.

- Is the crane properly supported and horizontally aligned?
- All applicable values for the current equipment mode as taken from the load capacity table are set and/or fulfilled?
- There are no persons or objects in the danger area of the crane.

DANGER: The crane operator must make sure while slewing the crane superstructure, particularly while operating when the working radius behind the ballasts and chassis are confined, that there are no persons or objects in danger. Before beginning any slewing movements, an acoustic signal (horn) must be given.

Visual inspection for damage

The crane operator must report damage or function that do not work properly to the operator who relieves him and to the responsible persons in charge of operations.

DANGER: The crane operator must immediately stop crane operations if any malfunctions should occur which endanger the operational safety of the crane. This applies particularly to:

- damage to load-bearing parts of the crane, such as the boom, supports, etc.
- overrun of the load (due to hoisting gear brake failure)
- faults in the crane control
- warning and indicator lamps that have burned out
- damage to the hoist cable
- damage to the tension cable and tension columns
- safety devices that no longer work
- crane hydraulics that leak

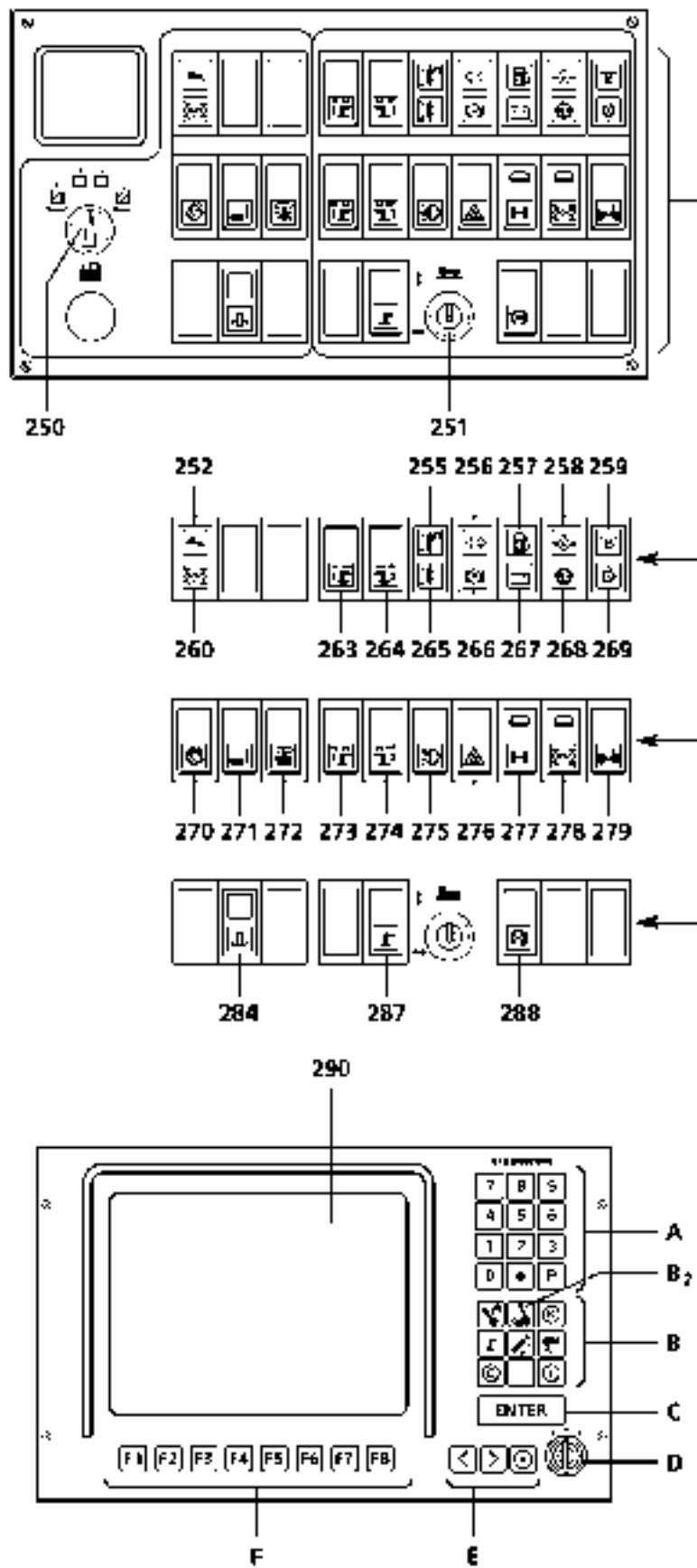

Setting the safety devices**Requirements:**

- Start the diesel engine for crane operations.
- As soon as the diesel engine is running and the generator provides power for the on-board power supply, the "LICCON" overload safety device switches on automatically and after a few seconds, the equipment mode diagram appears (290).
The last equipment mode diagram in which operations were carried out always appears.

Settings:

- Before beginning operations or changing equipment, the operating and equipment mode must be entered into the "LICCON" overload safety device in accordance with the load capacity table.

Note: If a function is changed in the operating mode and, or equipment mode, this change must be acknowledged with the (C)-ENTER key.
If an acoustic signal sounds after pushing the (C)-ENTER key, this indicates that the change has not been accepted.
Should this be the case, it must be determined which of the set functions is not correct.
See enclosed extensive "LICCON" operating instructions.

D A N G E R : **The proper functioning of the load torque limiter can only be guaranteed if the data as given in the load capacity table are correctly input and agree with the actual equipment mode of the crane.**
The crane operator is obligated to check, before beginning any crane operations, (even after briefly leaving the crane cab) that the settings on the overload safety device are correct.

Wind speed warning device *

Note: When operating with the folding fly jib, the wind sensor (which is detachable) must be mounted and fully functional - otherwise, the "LICCON" overload safety device will indicate a malfunction.

- Switch on equipment mode diagram with the program key (B2); a wind gauge symbol appears on the screen (290) of the "LICCON".
This shows the current wind speed.
If the maximum permissible wind speed is exceeded, a warning signal will sound and the wind speed display will blink.
Refer to the separate operating instructions of the "LICCON".

D A N G E R : **The device will not be switched off.**
Safe crane operations are only guaranteed if all settings have been carried out according to the load capacity table.

* Optional

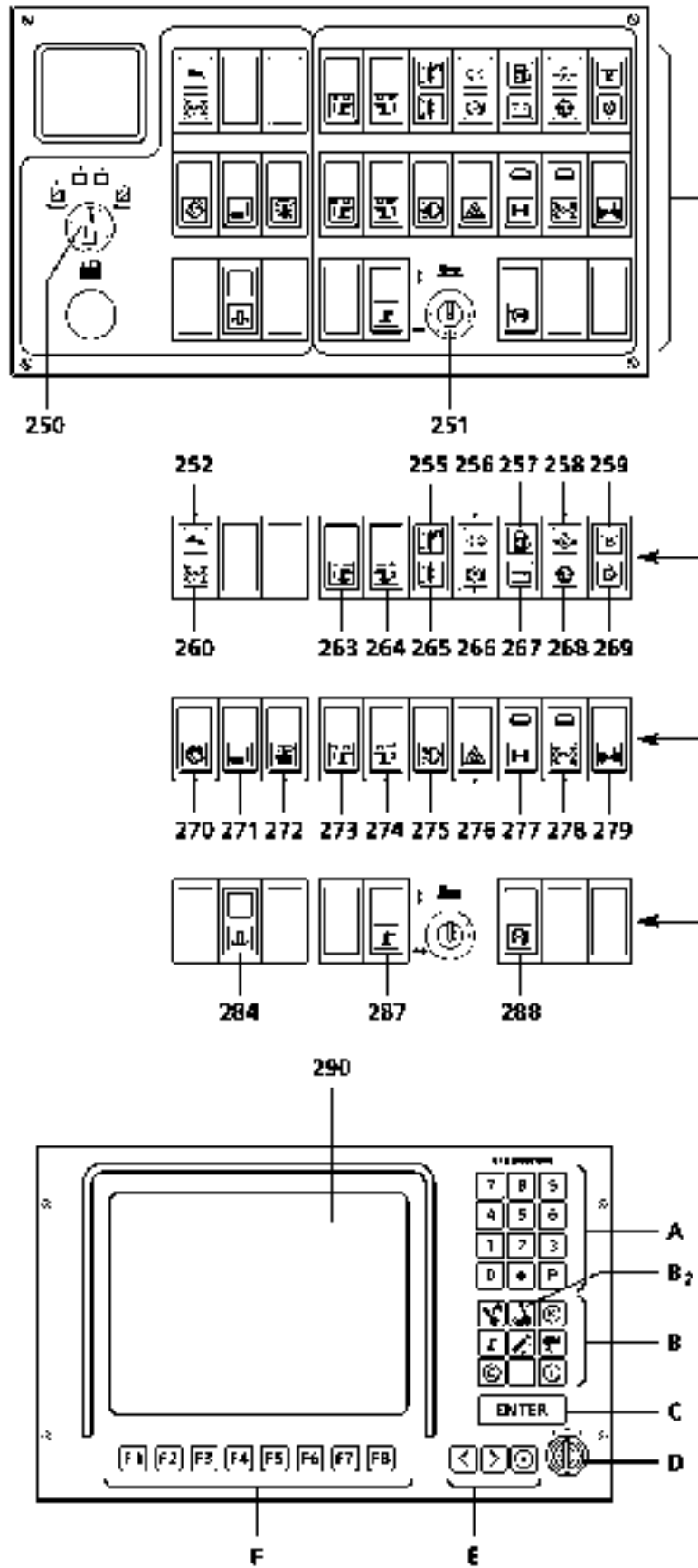

Checking the instruments**Requirements:**

- The diesel engine is running.
- the crane operation hydraulic pump (change-over switch in the driver's cab in position "superstructure") is switched on, indicator light (260) is lit.
- The equipment mode diagram is visible on the screen (290).

After starting the engine, immediately observe

Warning lamp (258) - oil pressure

During crane operations, observe

Warning lamp (268) - coolant temperature

Warning lamp (257) - fuel level

Warning lamp (267) - charge control

CAUTION: If warning lamp (258) does not go out or if either of the warning lamps (258) or (268) come on during crane operations, the engine must be shut down immediately. If this is not done, the engine can be damaged due to a lack of oil pressure.

Taking on a load

The crane must always be operated in such a manner that the load bearing parts are not destroyed and safety is always guaranteed.

Pulling at an angle is prohibited

The crane is built exclusively for hoisting loads vertically. Pulling at an angle, regardless of whether this is in the direction of the boom, or carried out crosswise to it, causes horizontal forces to occur from the load, in addition to the vertically acting forces. As these forces are transferred via the hoisting cable to the boom jib, they have an effect above a torque which corresponds to the height of the boom head pulley.

D A N G E R: **Pulling at an angle is prohibited!**
 Pulling at an angle can destroy the crane or cause it to topple over.

Pulling stuck or jammed loads free is prohibited

It is **prohibited** to pull stuck or jammed loads free with the crane.

D A N G E R: **Pulling stuck or jammed loads free with the crane is p r o h i b t e d !**
 This can cause the crane to topple over.

Hoisting the load

Hoisting the load must be done with the utmost care.

There is the danger of being crushed for persons who are nearest the area of the load to be hoisted.

If the hoisting tackle is manually placed on the load to be hoisted, the crane operator must sure that:

- the hands of the persons placing the tackle on the load are not crushed between the tackle and the load.
- arms and legs are not crushed by a swinging load while hoisting.

D A N G E R: **There is the danger of being crushed for persons in the area where the load is being hoisted.**

For 1 - 3 strand reevings, switching to high-speed is prohibited if the crane is loaded with more than 50% of its maximum permissible load at the current working radius.

Crane operation

A swinging load must always be kept under control.

Only safe, sensitive control of the crane functions can guarantee this. All crane movements must be started and braked slowly so that the load does not begin to swing.

D A N G E R: **A swinging load can damage the crane or cause it to topple over.**
 There is danger of accidents occurring!

Tag lines

As an aid to crane operator for accurately guiding the load, tag lines are recommended. In this way, undesired load movements and the resulting damage they can cause can be prevented.

Moving persons

The crane is not designed for moving persons.

Moving persons from one place to another on a hoisted load is prohibited.

D A N G E R : **Moving persons with the load or load tackle is.
There is danger of accidents occurring!**

Danger of being crushed

Lowering the load must be done with great care.

There is the danger of being crushed for persons who are nearest the area where the load is to be lowered.

D A N G E R : **Persons or objects must not be under the load when it is being lowered.
There is danger of accidents occurring!**

Working near overhead high-tension wires

When operating close to electrical overhead wires, make sure these are disconnected by trained personnel. If this is not possible, the danger area must be covered or blocked off.

If these measures are not possible, the following safe distances must always be kept between the crane/boom and the wires:

Rated voltage	Minimum distance
up to 1000 V	1 m
over 1 kV up to 110 kV	3 m
over 110 kV up to 220 kV	4 m
over 220 kV up to 380 kV	5 m
if the rated voltage is unknown	5 m

Note: If, despite all precautionary measures, a flashover occurs, observe the following:

- Remain calm
- Do not leave the crane cab.
- Warn all those around the crane to remain standing where they are and not to touch the crane!
- Move the crane out of the danger area.

D A N G E R : **If this is not observed, serious injury or damage can occur.
There is danger of accidents occurring!**

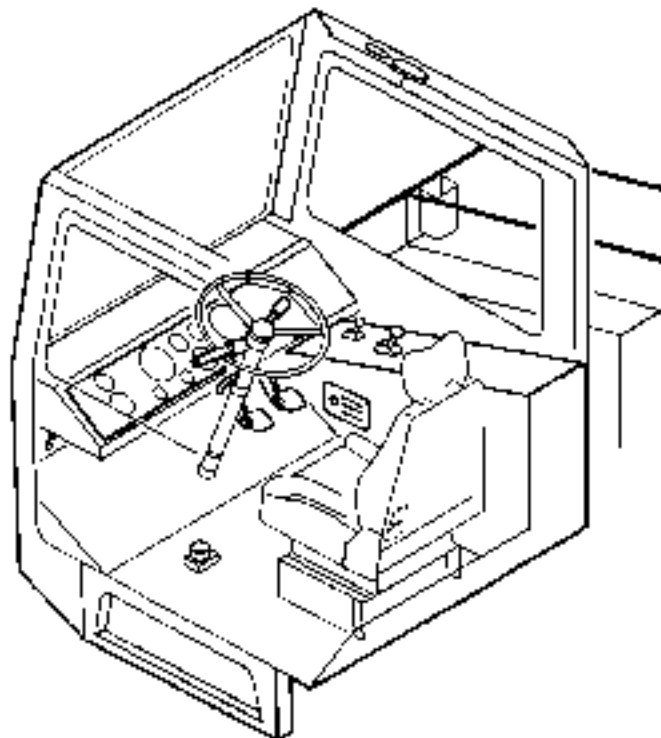
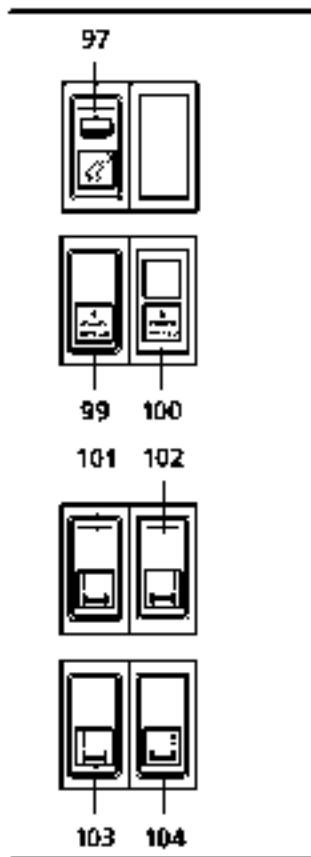
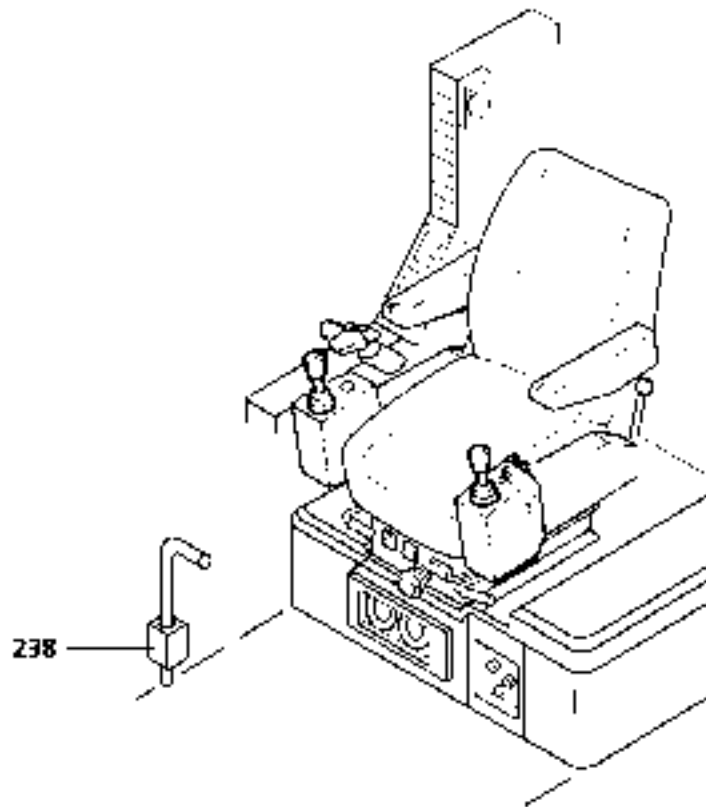
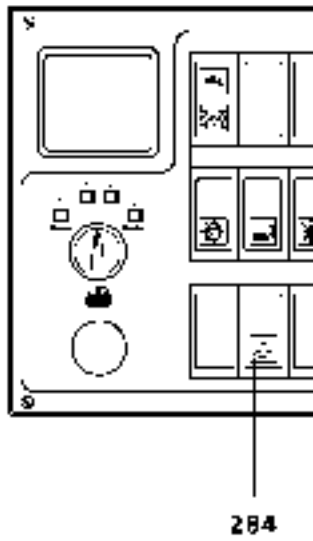

General Guidelines

The crane can be driven with a raised boom and with the attachment in place if it is positioned on level ground and the axle suspension system is locked.

DANGER: When driving with the attachment in place, it is imperative to adhere to the values and notes given on the following charts. If this is not observed, there is a great danger of accidents as the crane might turn over.

The following measures must be performed before driving:

When planning to drive the crane with or without the attachment in place, it must be assured that the support base as well as the driving surface are level, horizontal and of sufficient load carrying capacity.

1. Before supporting the crane and driving you must check the roadbed and driving surface to see if it is level or if there are any dips or uneven areas.

DANGER: The driving surface may not slope by more than 3°, even within the permissible tolerance range of +/- 0,10 m over 10 m length !

2. Installation of the attachment

CAUTION: The crane must always be supported before installation of the attachment.

Before supporting the crane, make sure to level the vehicle via the manual leveling system (99) in horizontal direction. Then you must lock the axle suspension by pressing the switch (97).

Complete the supporting procedure as described in chapter 3.05, **THE CRANE AT THE JOB SITE** .

If needed, install the jib head section .

Luff up the telescopic boom or telescopic boom with the jib head section to the angle given on the corresponding charts.

Turn the crane superstructure to the position given in the charts, either to the **front** or **rear**.

Lock the superstructure with the vehicle by using the locking lever (261), the indicator light (306) lights up.

DANGER: Before turning the crane superstructure, make sure the crane is properly supported according to the load capacity chart and horizontally aligned. The sliding arms must be pinned. After turning, the crane superstructure must be locked with the vehicle in lengthwise direction.

3. Lower the crane onto the blocked axles

Carefully lower the crane onto the blocked axles by retracting the outrigger cylinders.

DANGER: While lowering the crane, you must continuously check the horizontal position of the crane .

CAUTION: All wheels must touch the ground evenly, otherwise the axle suspension will be damaged!
The driving surface must be level and horizontal and it must be able to carry the axle load .

Charts for driving with the attachment in place

Chart 1: Retract the telescopic boom (T-8,4 m) all the way (0 / 0 / 0)

Chart 2: Retract the telescopic boom (T-8,4 m) all the way (0 / 0 / 0) with folding jib 0°, 15° and 30°

Driving operation

DANGER: The driving surface must be checked to see if it is level or if there are any dips or uneven areas in the road. The driving surface may not slope by more than 3°, even within the permissible tolerance range of +/- 0,10 m over 10 m length!
The driving surface must be level and of sufficient load carrying capacity.

Prerequisites:

- The crane superstructure must be positioned in lengthwise direction of the vehicle, either to the **front** or to the **rear** and it must be mechanically locked to the crane chassis.
- The axles must be blocked.
- The support cylinder with support pads must be lowered to about 10 - 15 cm above ground level, so that the crane is able to support itself, in the event that the ground gives.
- All tires must be properly inflated to the correct tire pressure .
- You may only drive in 1st gear (at slowest speed), with cut-in first axle drive and with utmost care, the least possible increase in speed and only with careful braking action.
- The ground must be level, horizontal and able to carry the axle load (see chart).
- There may be no persons or any obstacles within the travel range .
- During travel, another person must observe the luffed up boom as well as the outriggers to prevent any collision.
- It is only permitted to drive **without** a load on the hook.

CAUTION: These prerequisites must be observed and assured when driving with the attachment in place, otherwise there is a great danger of causing a serious accident, as the crane might turn over .

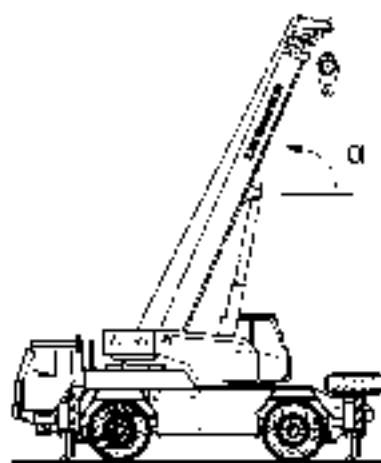
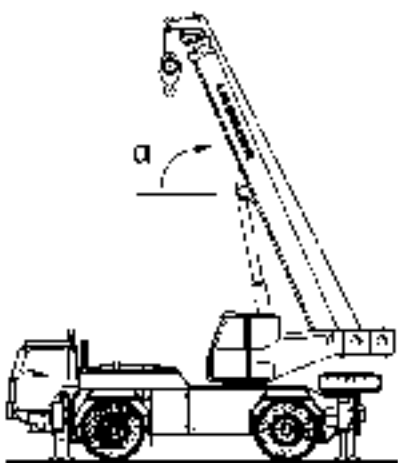
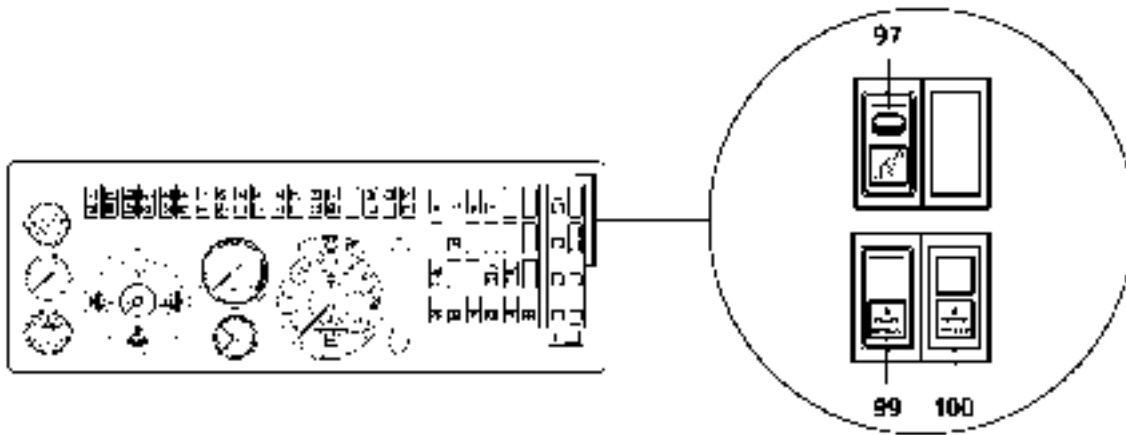

**Driving with an equipped crane
Telescopic boom (T - 8.4 m) fully retracted (0 / 0 / 0)**

Chart 1

	Counterweight on crane superstructure [t]	Telescopic angle \sphericalangle α to horizontal	maximum axle load [t]	
			1	2
Boom to the front	5.3	0° - 80°	9	21
	3.3	0° - 80°	10	18
	2.7	0° - 80°	10	17
	2.1	0° - 80°	10	16
Boom to the rear	5.3	0° - 80°	16	14
	3.3	0° - 80°	14	14
	2.7	0° - 80°	13	14
	2.1	0° - 80°	13	14

In the chart, a pulley block weigh t of 200 kg has been taken into consideration.
Slight increase of axle load if folding jib is installed on the side on the telescopic boom

- **The given distribution of the counterweight and the telescopic boom angles must be adhered to and may not be changed .**
- **Driving with raised boom is only permitted on level ground of sufficient load carrying capacity, without a suspended load !**
- **The hydro - pneumatic suspension of axles 1 to 2 must be blocked.**
- **The support pads must be held close to the ground level .**

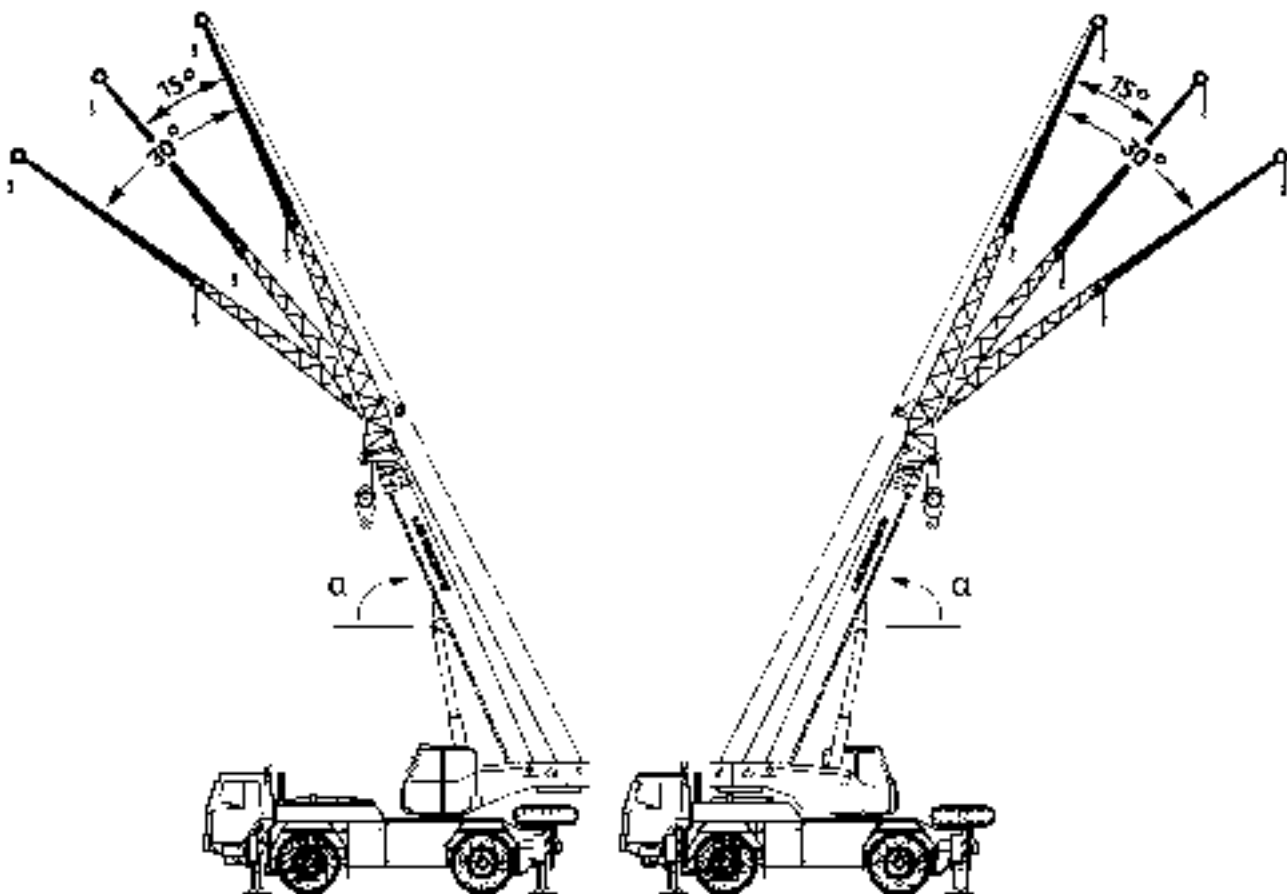
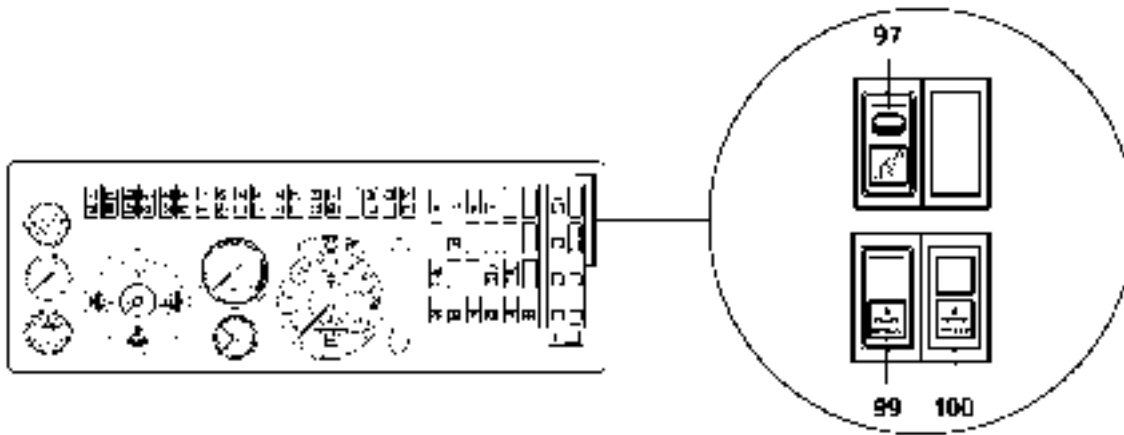

Driving with an equipped crane**Telescopic boom (T - 8.4 m) fully retracted (0 / 0 / 0) with folding jib 0°, 15° and 30°****Chart 2**

	Jib boom	Counterweight on crane superstructure [t]	Telescopic angle \sphericalangle α to the horizontal	maximum axle load [t]	
				1	2
Boom to the front	K - 8.2	5.3	20° - 80°	11	21
		3.3	20° - 80°	11	18
		2.7	20° - 80°	12	17
		2.1	20° - 80°	12	17
	K - 14.4	5.3	20° - 80°	12	21
		3.3	20° - 80°	13	18
		2.7	20° - 80°	13	18
		2.1	20° - 80°	13	17
Boom to the rear	K - 8.2	5.3	20° - 80°	16	16
		3.3	20° - 80°	14	16
		2.7	20° - 80°	13	16
		2.1	20° - 80°	13	15
	K - 14.4	5.3	20° - 80°	16	18
		3.3	20° - 80°	14	17
		2.7	20° - 80°	13	17
		2.1	20° - 80°	13	17

On the chart, a pulley block weight of 120 kg has been taken into consideration.

- **The given distribution of the counterweight and the telescopic boom angles must be adhered to and may not be changed.**
- **Driving with raised boom is only permitted on level ground of sufficient load carrying capacity, without a suspended load !**
- **The hydro - pneumatic suspension of axles 1 to 2 must be blocked.**
- **The support pads must be held close to the ground level .**

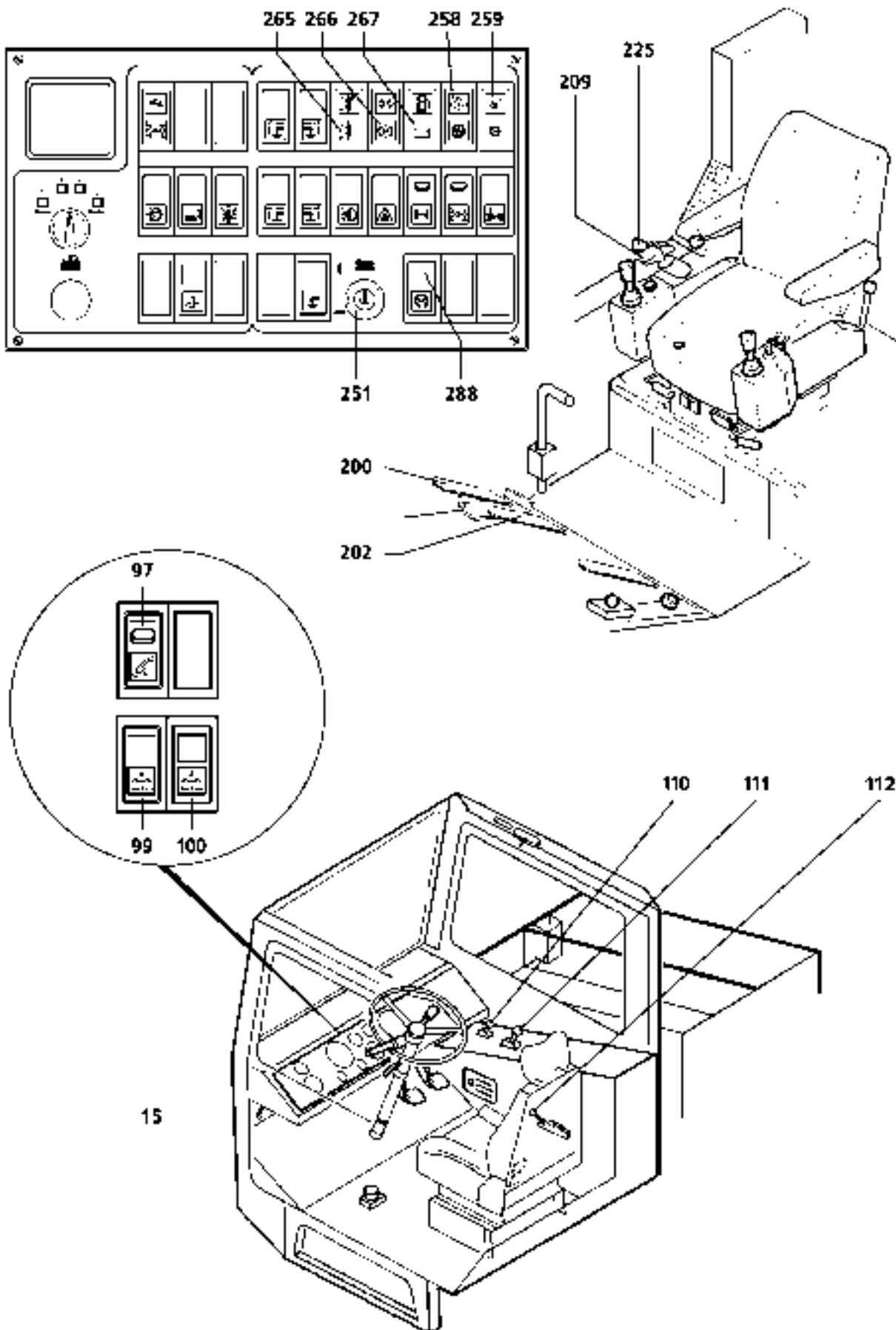

Requirements:

The checks and measures described in Chapter 3.02 BEFORE DRIVING have been performed.

Switching to "Driving from the crane operator's cab"**Engine is at standstill,**

- Ignition in the driver's cab is switched on
- Switch change-over switch (15) to position "superstructure".

CAUTION: Change-over switch (15) may only be activated with the engine at standstill.

Note: Switching over to position "superstructur" automatically locks the axle suspension. Additionally, switch (97) should be switched to AXLE SUSPENSION LOCKED for safety. If the change-over switch (15) is activated with the engine running, the driving engine shuts off automatically.

CAUTION: Each time before switching over the change-over switch (15) hand brake levers (110) in the driver's cab and (225) in the crane operator's cab must be engaged.

The following functions are now switched to in the crane driver's cab:

Steering, gear selection, manual brake, electronics.

- Switch off ignition in the driver's cab.

Switch on ignition in the crane cab

- Insert key into ignition (251) and turn one notch clockwise.
- Switch the gear selector (209) switch to neutral "N".

Note: The engine can only be started in position "N"

Start the engine

- Turn the key further clockwise and start the engine.

Note: When starting the engine, do not depress the accelerator.

CAUTION: The engine can only be started when the preheater indicator light (259) blinks.

Starting procedure at temperatures under 0 °C**1. Preheating**

When the ignition/start switch is switched to position "1" (driving), the preheating interval of ca. 40-50 sec. begins.

The preheating interval is displayed by indicator light (259) blinking.

If the engine is started during the preheating interval, the preheating procedure is automatically interrupted, in this case, repeat preheating.

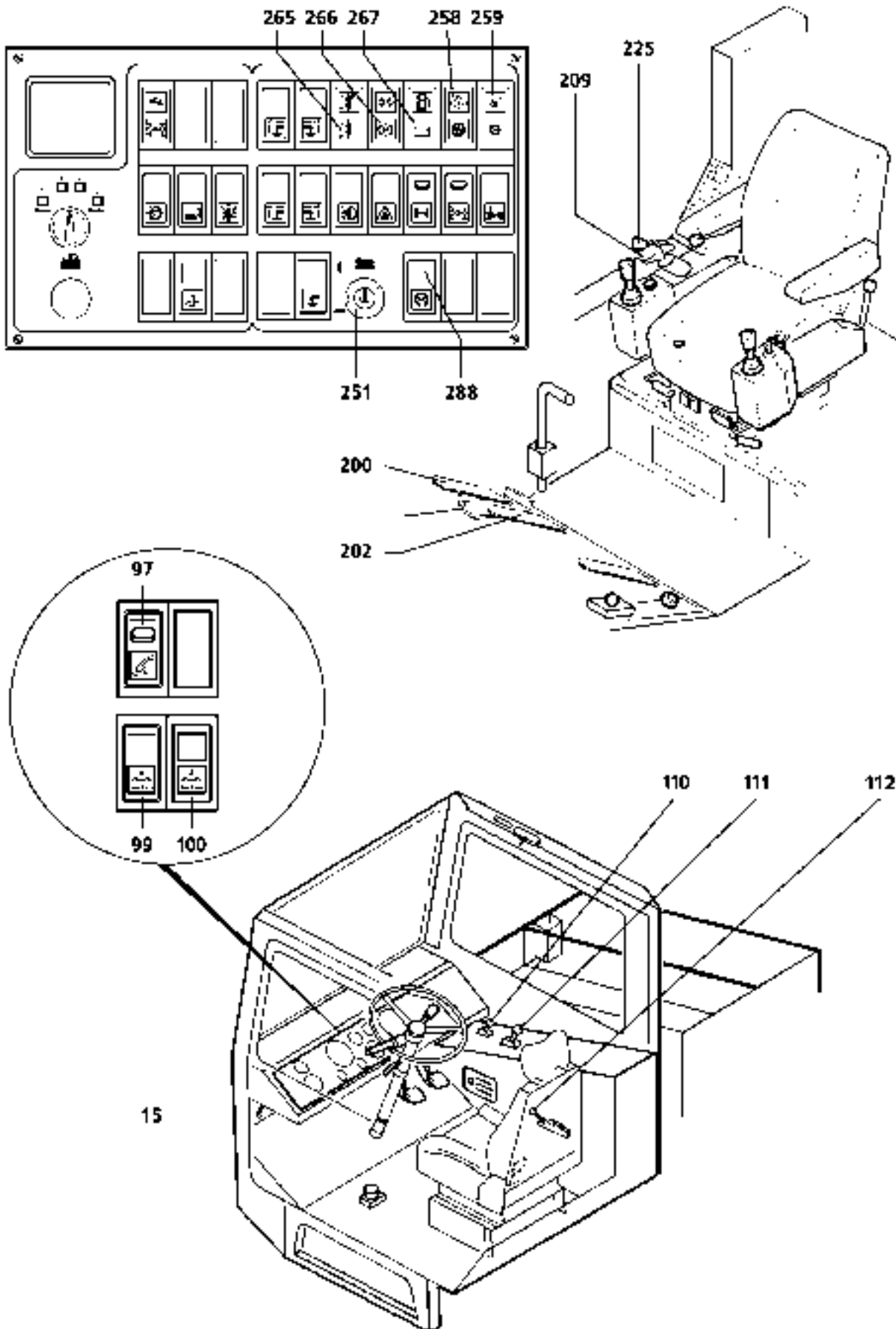

2. Starting the engine

After the preheating interval, indicator light (259) shuts off and the start readiness interval of ca. 30 sec. begins.

The engine is started by turning the ignition/start switch further to position "2" (start).

The charge indicator light (267) must light up.

Note: Start the motor without activating the accelerator pedal.

If the engine is **not** started during the start readiness interval, the start readiness interval is automatically over (in this case, repeat points 1 and 2).

If after ca. 5 seconds the engine doesn't start, slowly depress the engine regulator accelerator pedal.

If after ca. 20 sec. the starting procedure is still unsuccessful, allow a 1 minute pause.

The starter can be activated for 3 x 20 sec. per starting procedure, with one minute pauses between attempts.

Observe the oil pressure warning light (258) immediately after starting the engine.

CAUTION: If the warning light (258) does not shut off, or if it lights up during crane operation, shut off the engine immediately.

If this is not done, the engine may sustain damage due to too low oil pressure.

The engine must be shut off immediately if:

- the oil pressure sinks or varies severely,
- the power and speed sink without the position of the control setting lever being changed,
- the exhaust is particularly smoky or the exhaust manifold temperature rises.
- the coolant water and oil temperatures rise,
- abnormal noises are suddenly emitted from the motor or the turbo-supercharger.

Starting procedure for outside temperatures above 0 °C

When starting the engine warm, do **not** depress the accelerator pedal; this guarantees a smokeless start.

The following indicator lights must go out when the driving engine is running:

- Driving engine charge indicator light (267)
- Engine oil pressure (258)

3. Shutting off the engine

Relieve load on the engine, Reduce the engine speed gradually, so as to avoid overheating the coolant, then allow the engine to run for a short time at idle speed.

This should be observed particularly for supercharged engines, while this gives the turbo supercharger, which is running at high speed, a certain amount of time to run down.

If the engine is shut off suddenly, the turbo supercharger runs for a while without oil supply.

Shut off the engine using button (288).

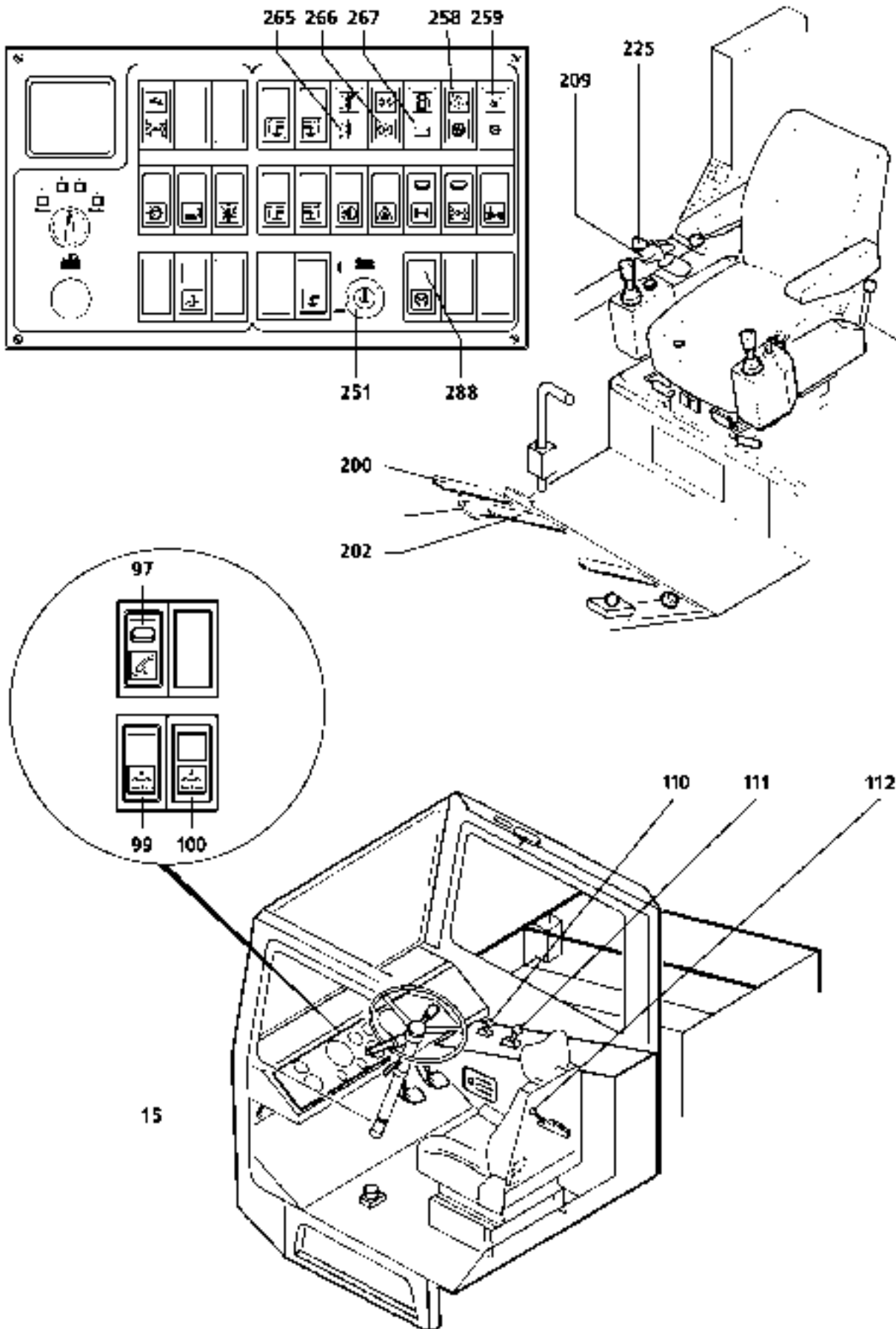

Checking the service brake system

- Slowly depress the service brake foot pedal (202) all the way down.

Note: The parking brake (225) can be released once the ca. 5.2 bar pressurized air reserve in brake circuit III is reached.

Ready to drive - engine runs at idle

- Choose the desired driving range with gear selector switch (209).

Release the parking brake

- Pull out manual lever (225) to its stop along its longitudinal axis and press forward; indicator lamp (266) goes out.

Note: With the parking brake disengaged, the manual lever points forward.

C A U T I O N: **Until the required brake release pressure (ca. 5.2 bar) in brake circuit III is reached, the parking brake is not released, even if the hand lever is moved forward. Move the hand lever back again and fill brake circuit III.**

Service brake

- Increase engine rpm with foot pedal (200); the crane will begin to move.

C A U T I O N: **Immediately after the crane begins to move, the brakes must be tested.**

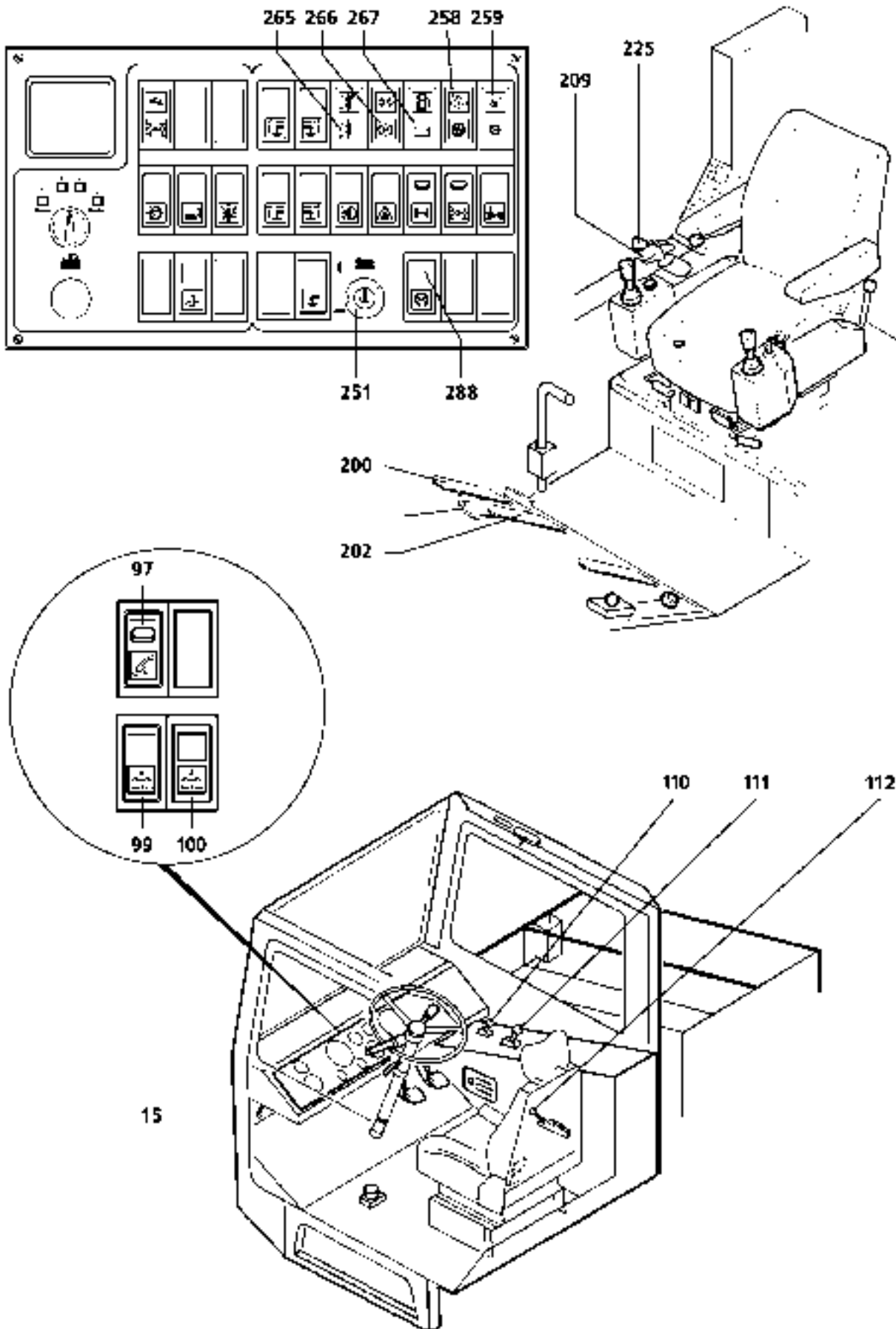

Readying the vehicle for driving

Motor is running at idle speed.

- Select level 1 with the gear selector switch (209) (forwards or backwards, as required).

Note: If indicator light (265) is lit, reverse gear must be selected to travel in the direction of view.

- Release the hand brake.
With the hand brake open, the hand brake lever points forwards.
To release the hand brake, pull out the switch block in the lengthwise direction of the hand lever and rotate the hand brake lever forward.
The crane will now begin to move slowly.

Shifting

2 forward and 2 reverse gears are available for driving the crane from the crane operator's cab.

CAUTION: Travel levels R1 and R2 correspond to travel levels 1 and 3 for forwards travel.

Driving speed is controlled via the foot pedal (200) and the gear selector switch (209) of the transmission. The individual gears can be selected under load.

In order to protect the engine from overrevving, only shift down when the highest speed of the lowest gear is reached. If required, brake the crane with the service brake to reach this speed.

Braking

- Test the brakes immediately after beginning to drive.

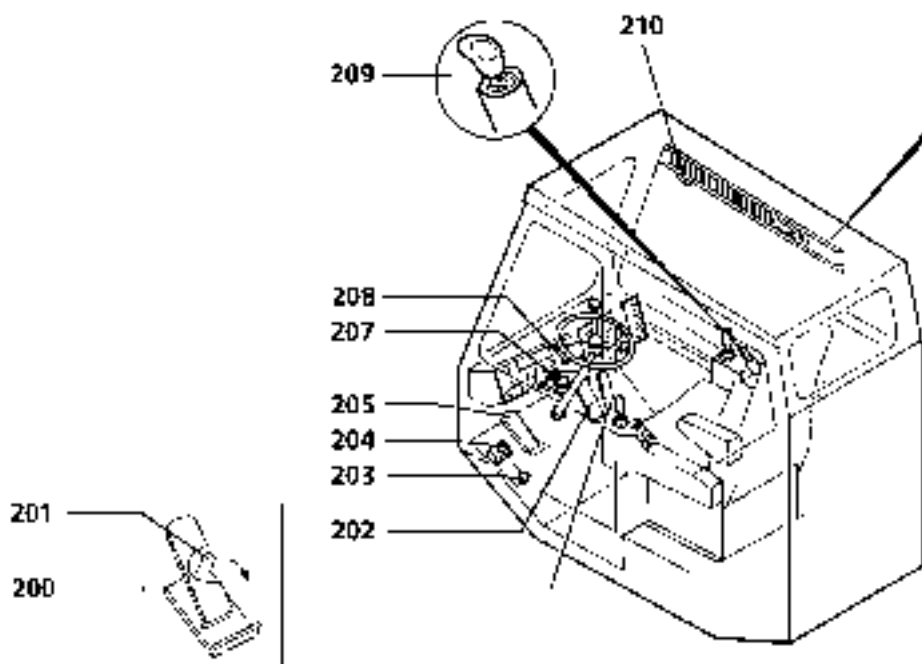
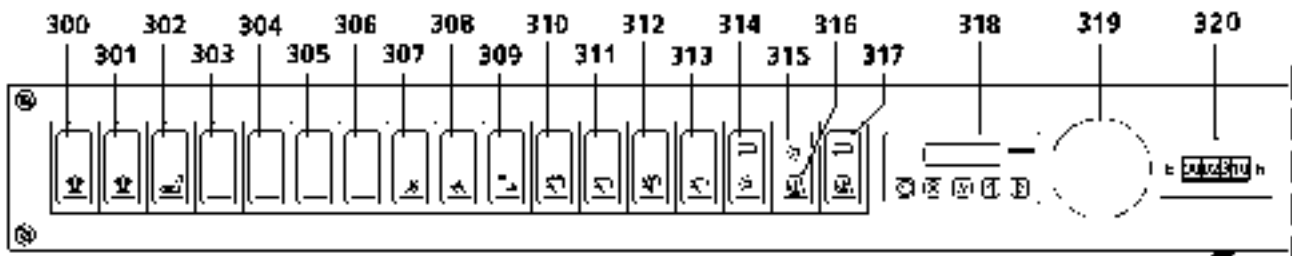
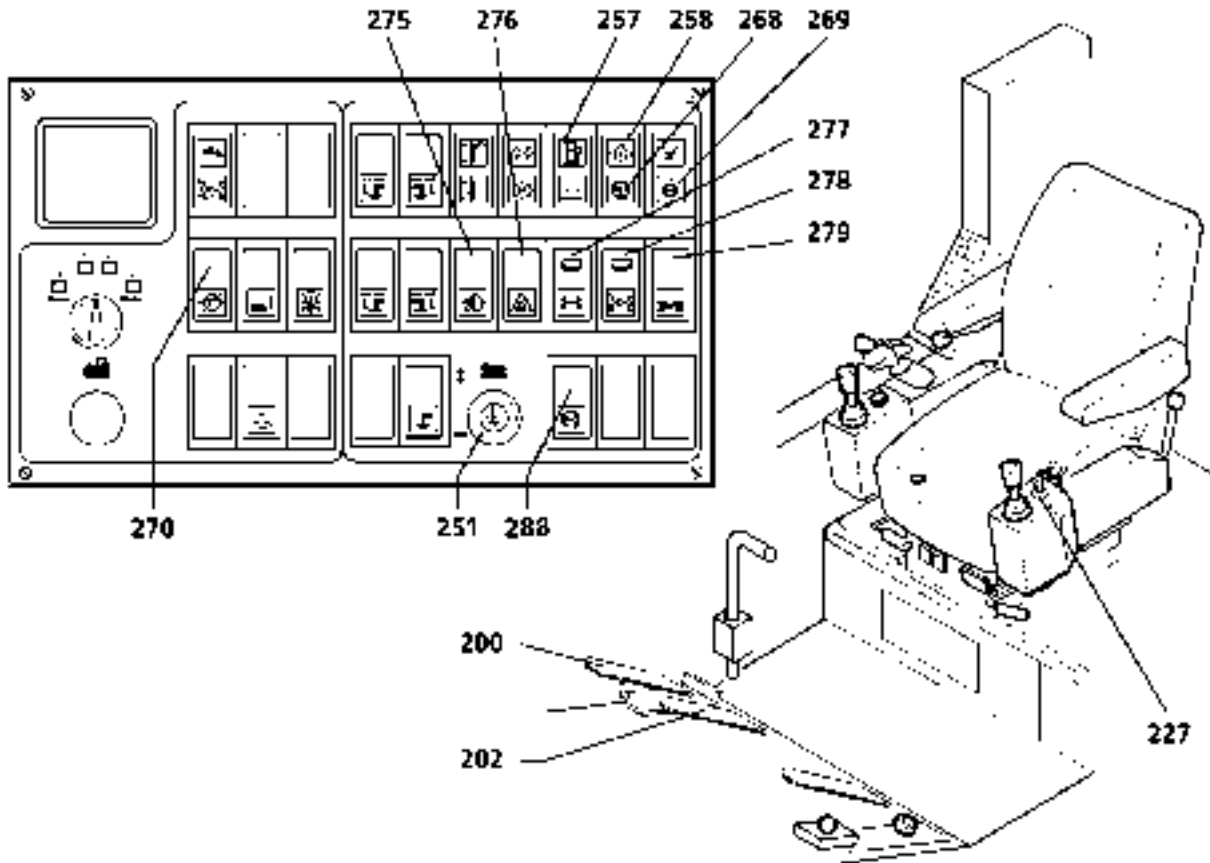

Driving operation

The following instruments, which are important for driving operation, should be observed while driving:

1. Warning light Oil pressure (258).

If this light comes on while underway, and doesn't shut off when engine speed is increased, the crane must be brought to a stop and the engine must be shut off.

CAUTION: If the warning lamp (258) does not go out while driving, the crane must be brought to an immediate stand-still and the engine must be shut down.
Too little oil pressure and too high engine temperature can lead to engine damage.

2. Warning light coolant temperature too high (268).

If this light comes on while underway, first try to get the temperature into the proper range and thus shut off the light by reducing load on the engine and raising the engine speed.

If this does not work, bring the crane to a stop and shut off the engine.

CAUTION: If the coolant temperature cannot be lowered to the permissible range, the crane must be brought to an immediate stand-still and the engine must be shut down.
Too high engine temperature can lead to engine damage.

3. Warning light torque converter/power shift gearbox oil pressure / oil temperature (269).

If the temperature becomes too high while underway, first attempt to bring the temperature within the proper range between 85 °C and 90 °C by reducing the load and raising the engine speed.

If this light comes on while underway, bring the crane to a stop and regulate the engine speed to ca. 1500 rpm.

If the warning light does not shut off within a short period of time, shut off the engine.

4. Warning light fuel level (257)

Make sure that the fuel tank is never run dry, as this causes dirt residue to be sucked into the fuel system, requiring the fuel system to be cleaned and ventilated.

Therefore, as soon as warning light (257) comes on, add diesel fuel.

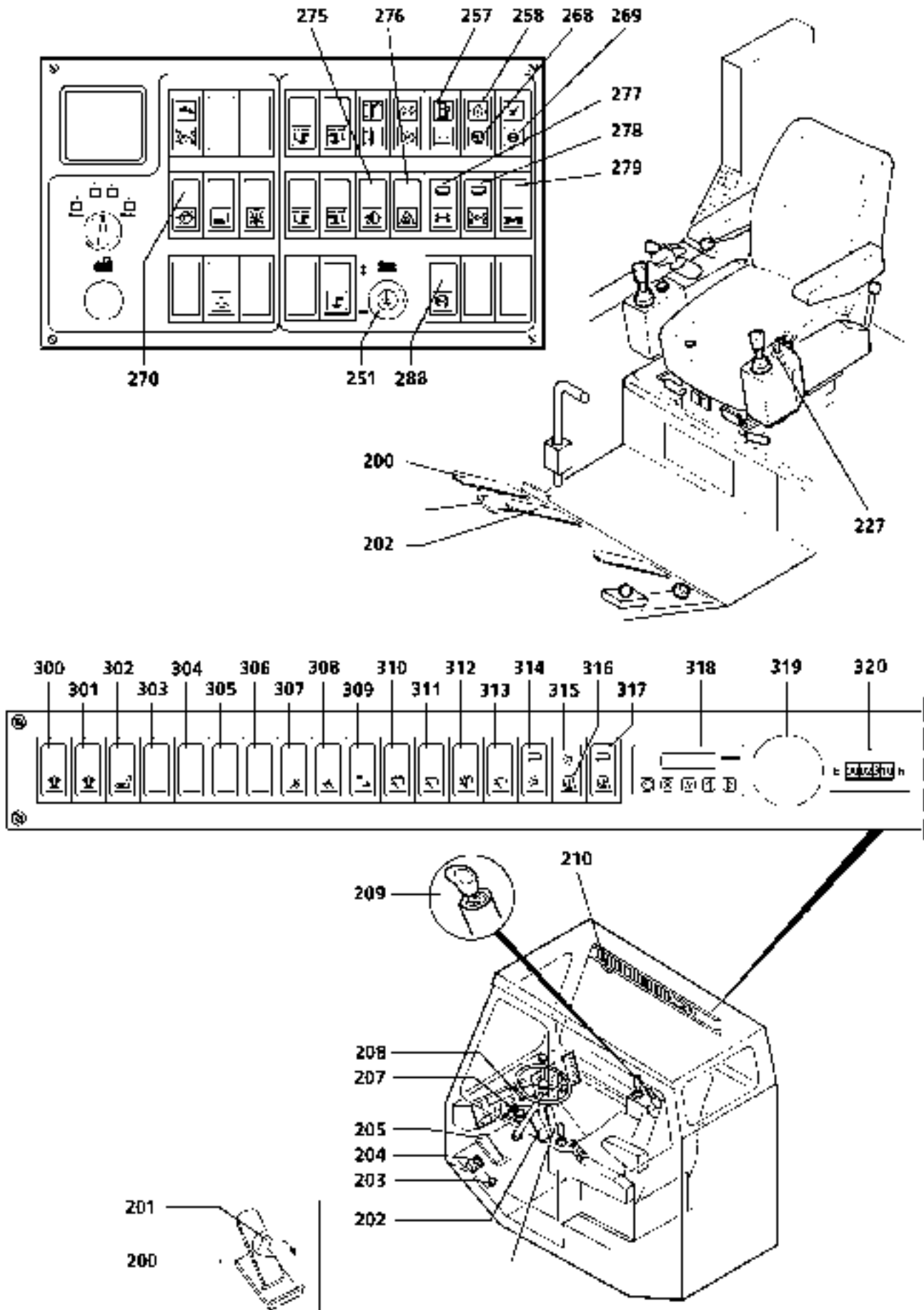

Off-road driving

For off-road driving, driving on unpaved surfaces, and during winter conditions, additional gears are provided which may only be shifted to in the following order with the crane at a standstill:

1. **Front axle drive (off-road gear)**
2. **Swinging * the front axle**

1. Switching on the forward axle drive

As soon as one or both wheels begin to slip, the forward-axle drive can be switched on using switch (278).

Note: Move off carefully.
The forward axle drive is switched on once the indicator light in the switch lights up.

CAUTION: It may only be switched on with the vehicle and a standstill and the gear selector switch in neutral position.
Move off carefully. The forward axle drive is engaged as soon as the indicator light (278) comes on.
As soon as the front axle drive, is no longer absolutely required to continue driving (on firm surface providing traction), it must be switched off again immediately.
Driving on a solid surface with good traction with the front axle drive engaged can cause considerable damage to the driven axles and the whole drive train!

2. Switching on the front axle swinging *

The front axle swinging* provides better off-road mobility on uneven terrain.

CAUTION: It can be switched on only if the boom is pointing to the rear and the crane superstructure is locked to the chassis with the locking pins (238).
The front axle is switched to swinging as long as button (279)* is held pressed down.

Note: Axle suspension for off-road driving see under "AXLE SUSPENSION / LOCKING SYSTEM", Chapter 3.03.

* Optional

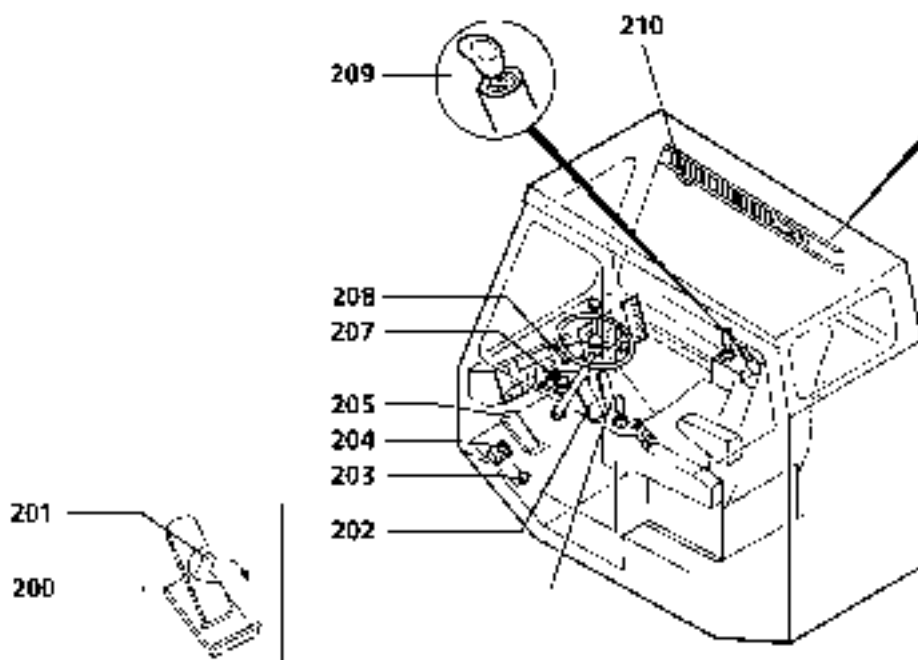
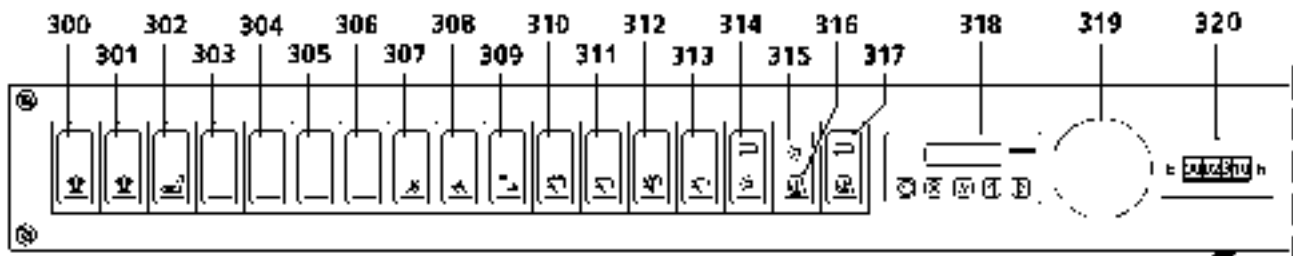
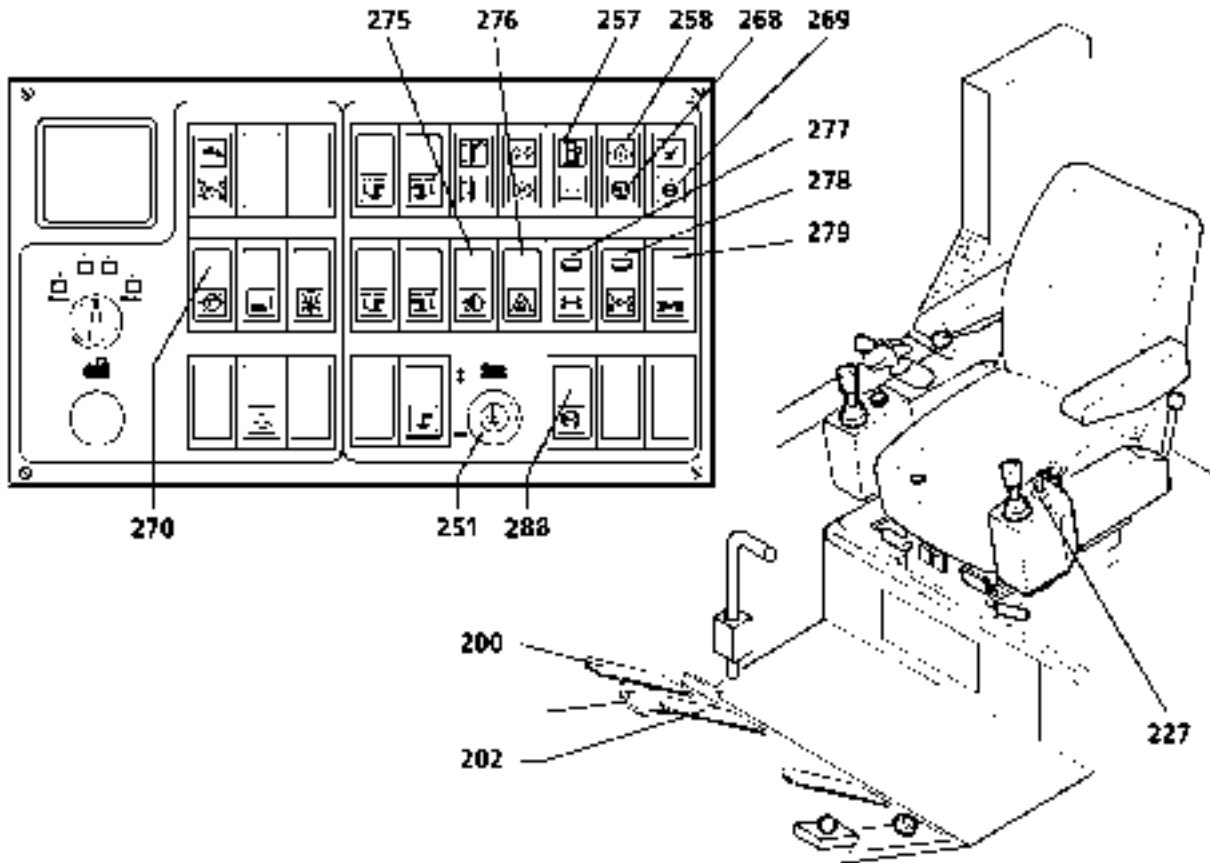

Rear axle steering *

The rear axle steering makes it possible to lock in the 1st and 2nd axle wheels in the same direction, allowing the crane to move sideways (crabbing motion) and turn in a tight radius.

CAUTION: Rear axle steering must not be engaged or operated on public roads.
Rear-axle steering switch (277) must be switched off for driving on streets.
The steering direction of the rear axle must be checked by observing the rear wheels.

Putting into operation

- Bring the crane to a standstill on even ground.
- Move the wheels to straight travel.
- Switch to neutral.
- Open the rear axle steering lock via switch (277).

Note: Disengaging is possible in neutral, in 1st and 2nd gear, and in 1st reverse gear.

- Move the steering switch (227) lightly to the right and the left.

Note: If the rear axle steering is not successful, the steering locking / unlocking is in an intermediate position.
In this case, the switch (277) must be switched on and off again.
After this, move the steering switch (227) lightly to the right and the left.

- Via the steering button (227), the rear axle can now be steered left or right independently of the two front axles.

Disengaging rear axle steering

CAUTION: As soon as rear axle steering is no longer required, it must be disengaged on even ground before continuing.

- Bring the crane to a standstill on even ground.
- Bring the wheels to the straight ahead position.
- Close steering lock of the rear axle via switch (277).
- Make sure that rear-axle steering is locked; i.e. activate the steering button lightly to the right and the left while watching the wheels of the rear axle: steering must no longer be possible.

* Optional

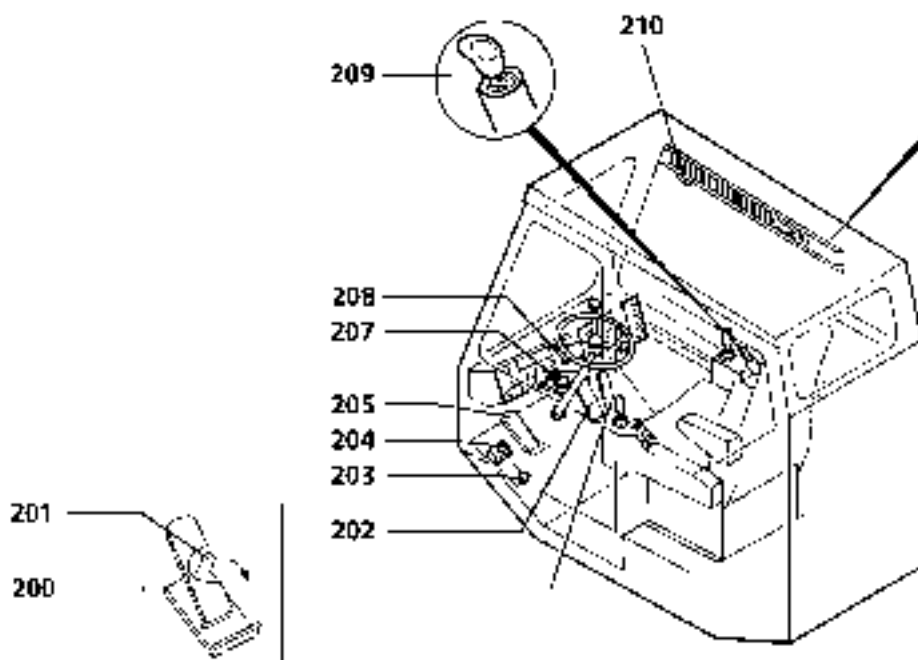
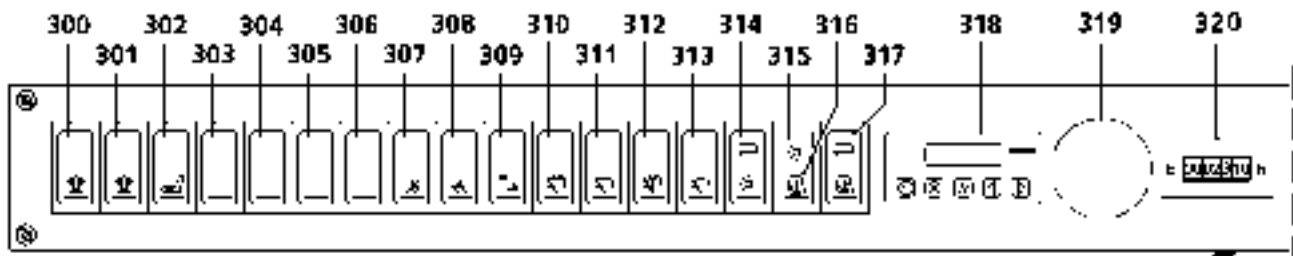
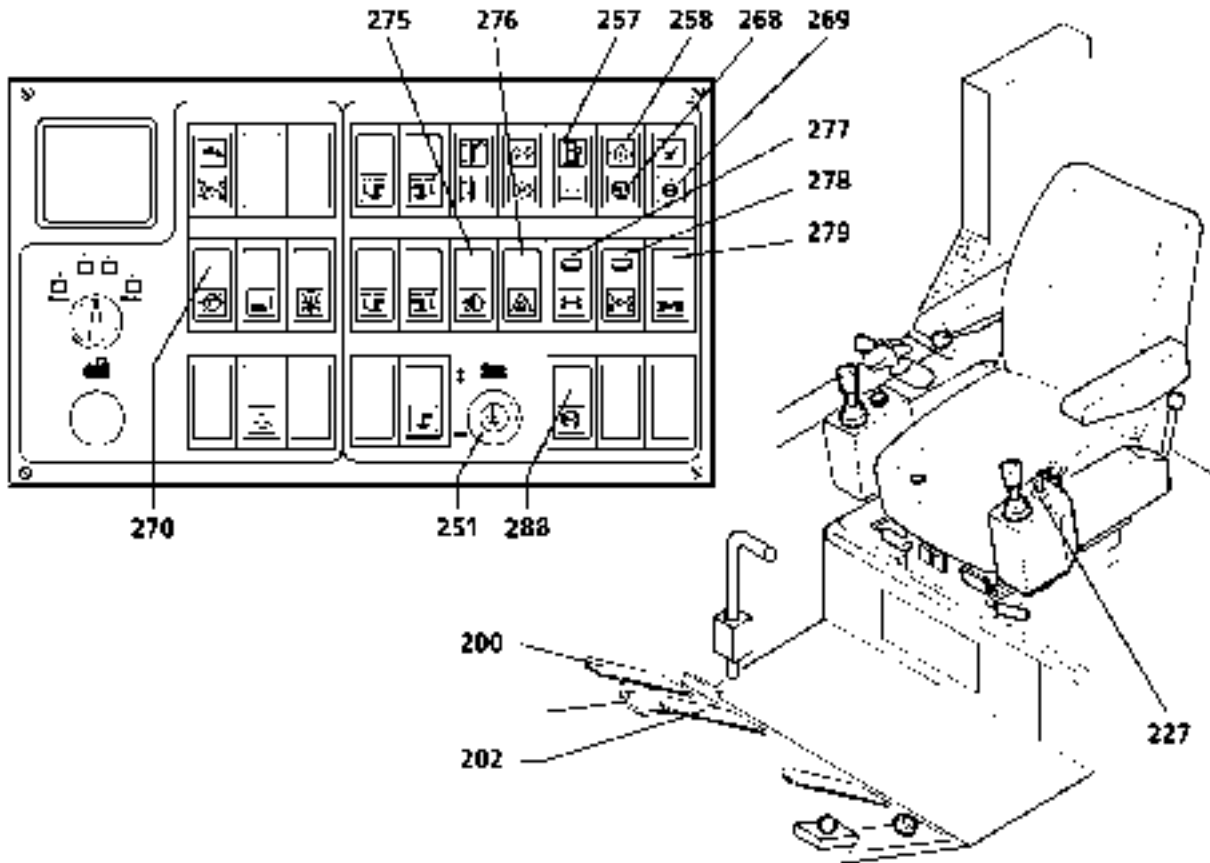

Further equipment for driving

- The windshield wiper for the front window is switched on with switch (313).
- The windshield wiper for the roof window is switched on with switch (311) *.
- Parking and low-beam lights can be switched on with the 2-stage switch (275).
- The hazard warning flashers are activated with switch (276); their function is indicated by the blinking indicator lamp in the switch.
- The control panel can be illuminated - switch (270).
- The crane operator's cab is provided with an interior light, (210).

Ending the journey

- Brake the crane to a halt with the service brake (202).
- Engage the parking brake, switch to neutral.
- To equalize the temperature, allow the engine to run for a short time longer at idle speed.
- Press the engine stop button (288) until the motor stands still.

* Optional

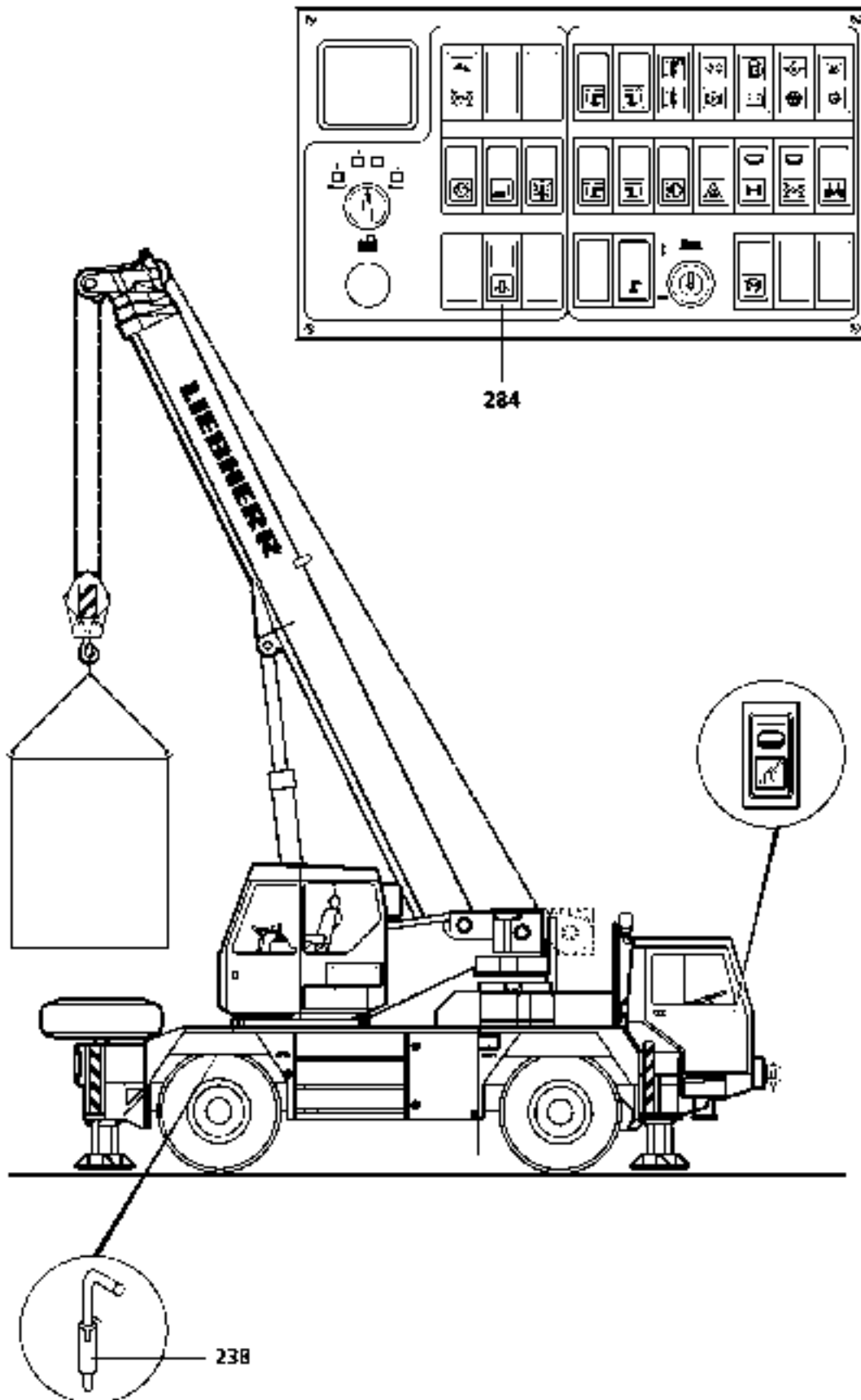

The crane can be operated "free-standing" if the information in the corresponding load capacity table as well as the following instructions are followed:

A) Crane operation "free-standing on tires"

1. The foundation must be capable of supporting the maximum operating weight of the crane (approx. 24 t) in addition to the weight of the suspended load.
2. The foundation must be even and without inclination.
3. The LICCON overload safety device must be set to the equipment mode "free standing on tires, working range 360°" (see load capacity table and LICCON overload safety device operating instructions).
4. The telescopic boom may only be extended to a maximum length of 14.3 m.
5. The axle suspension must be blocked via the rocker switch in the crane cab.
6. The tires must be inflated to the prescribed air pressure (see load capacity table).
7. The 4 sliding arms should be extended and the support jacks with the support pads mounted should be lowered approx. 15-10 cm above the ground so that the supports can catch the crane should the ground give way.
8. For safety reasons the crane should always be supported during operations, even when free-standing crane operations are possible.
9. Always prevent the suspended load from swinging.

B) Driving with load, working range "to the rear "

The crane may be driven with a hung load only, if there are existing load capacity tables for "free-standing on tires, working range to the rear".

In addition, the values listed under **A)** must be adhered to.

Additionally, the following must be noted:

1. For the crane operating mode "free-standing on tires, working range to the rear", the crane superstructure must face the rear along the direction of travel and be mechanically locked to the chassis with the pins (238).
Indicator lamp (284) * must be on.
2. Operating in the working range 360° is **not** permitted.
3. Driving with a suspended load must only be carried out **in 1st gear at crawl speed**, with the slowest acceleration, and careful braking.

* Optional

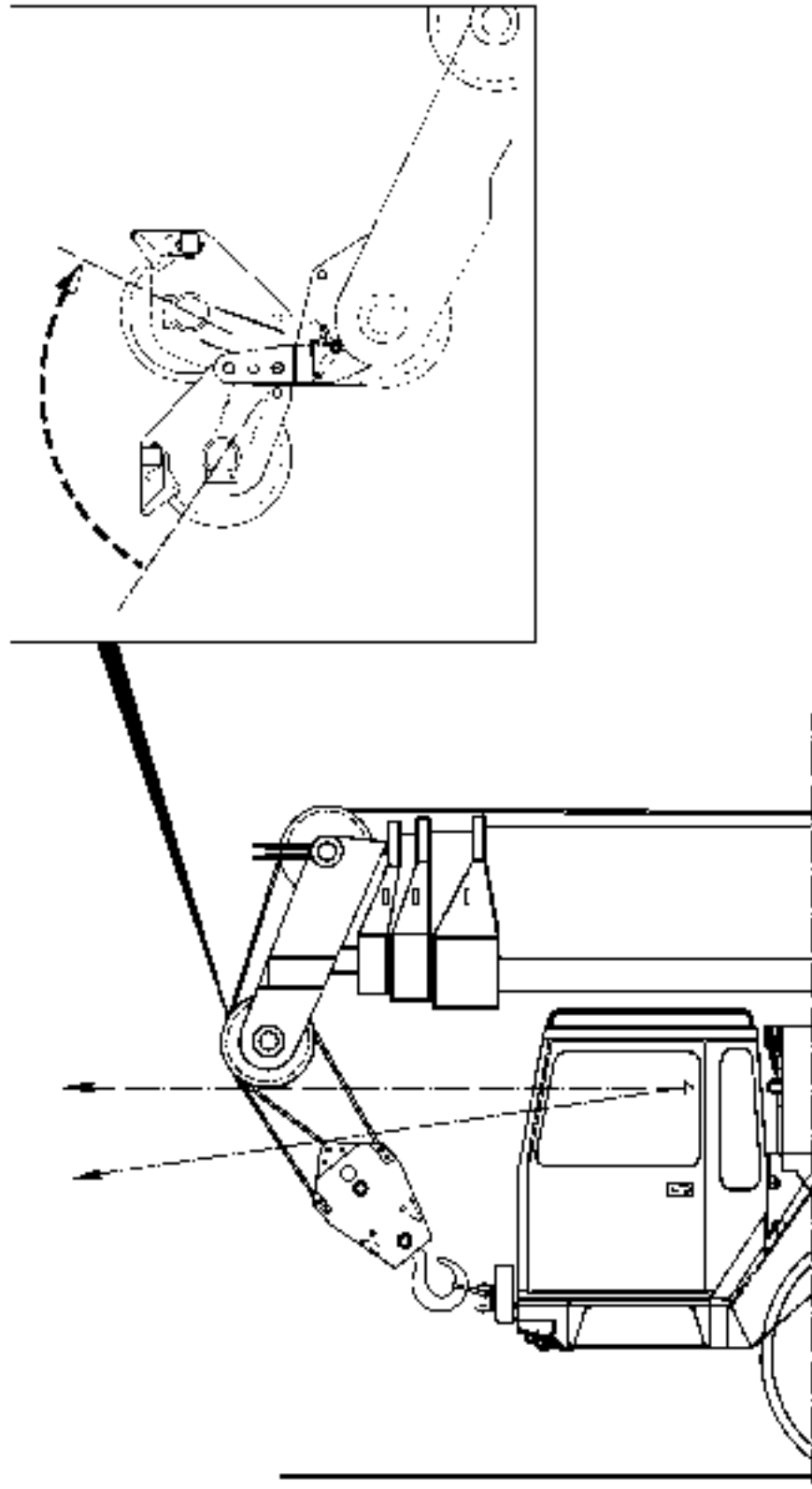

Description

In two-hook operations, a distinction must be made between

1. Operating with a derrick hook and
2. Operating with a boom extension (special auxiliary boom, fly jib, luffing jib).
3. Operating with a load turning device.

1. Operations with the derrick hook*

The capability is set up for quick hoists via hoisting gear II, whereby reeved hook block (hoisting gear I) on the telescopic boom may remain completely reeved.

DANGER: Safety via the LICCON overload safety device is only provided if the 1-cable reeving have been entered!

In this case, simultaneous operation of two hooks is not permitted!

- Set the LICCON overload safety device to the operating mode "Tele-operations or L-mode".
- Enter cable reeving in the equipment mode diagram of the LICCON overload safety device with "1".

Note: Refer to separate LICCON operating instructions.

CAUTION: The LICCON overload safety device must be set to 1- cable reeving, and the corresponding code no. of the respective telescopic boom length must be entered.

In addition, the ballast, support base, etc., must also be considered.

Setting 1-cable reeving ensures that the crane cannot be overloaded.

The maximum total load corresponds in this case to the max. load on the individual cable.

The weight of the hook block and the slinging tackle must be added to the loads to be hoisted.

CAUTION: In this case, the radius and load display of the LICCON is not precise because the derrick hook is not considered in the boom geometry.

* **Special equipment**

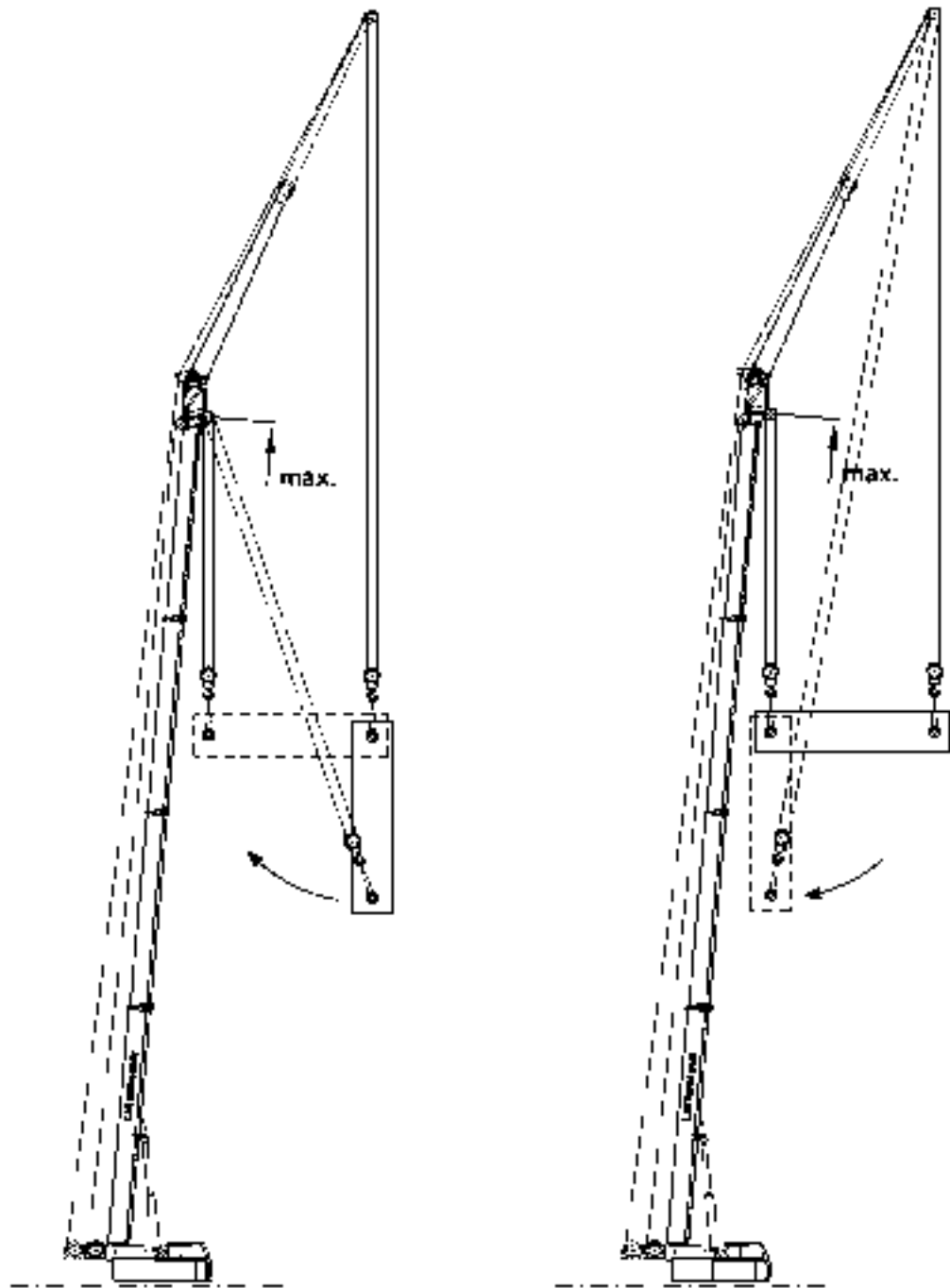

Va. 1

Va. 2

2. Operations with the folding fly jib and with the special auxiliary boom*

This capability is provided for turning the load while simultaneously operating both hoisting gears.

DANGER: The load must always be raised or lowered to 100% with the weakest component (fly jib or special auxiliary boom*).

- Enter the reeving in the LICCON in accordance with the reeving present (folding fly jib or special auxiliary boom *).

DANGER: The reeving on the main hook (telescopic boom) must be equal to or larger than the reeving on the jib (folding fly jib or special auxiliary boom*).
If this is not observed, hoisting gear 1 or the hoisting cable could be overloaded.

- For operations with the **folding fly jib and the special auxiliary boom***, the LICCON must be set to the operating mode "**Folding fly jib**".
- Enter the cable reeving in the equipment mode diagram of the LICCON in accordance with the reeving present on the jib.

In this case the maximum total load corresponds to the maximum permissible load on the folding fly jib given in the corresponding load capacity table for jib operations.

The weight of the hook block and the slinging tackle must be added to the loads to be hoisted.

CAUTION: The radius display is given corresponding to the entered folding fly jib.

The individual loading capacity per hook during two-hook operations corresponds to the permissible load given in the appropriate load capacity table for operations with folding fly jib.

The sum loading capacity corresponds during two-hook operations to the permissible load given in the appropriated load capacity table for operations with folding fly jib.

DANGER: Hoisting a load with 2 hooks is only permissible in accordance with diagrams Va.1, Va.2 and Va.3.
If this is not observed, there is a danger of accidents due to the overloading of the individual crane components.
Protection via the overload safety device is then no longer provided.

If a load is hoisted in accordance with Va.1, the load must first be completely hoisted to 100% with the most outer hook.

Note: As soon as the inner hook is drawn, the load display in the overload safety device is incorrect!

DANGER: If both hook are loaded, luffing the boom is prohibited!
Protection via the overload safety device is then no longer provided.
For this reason, the load must always be taken up at the maximum radius.

* Special equipment

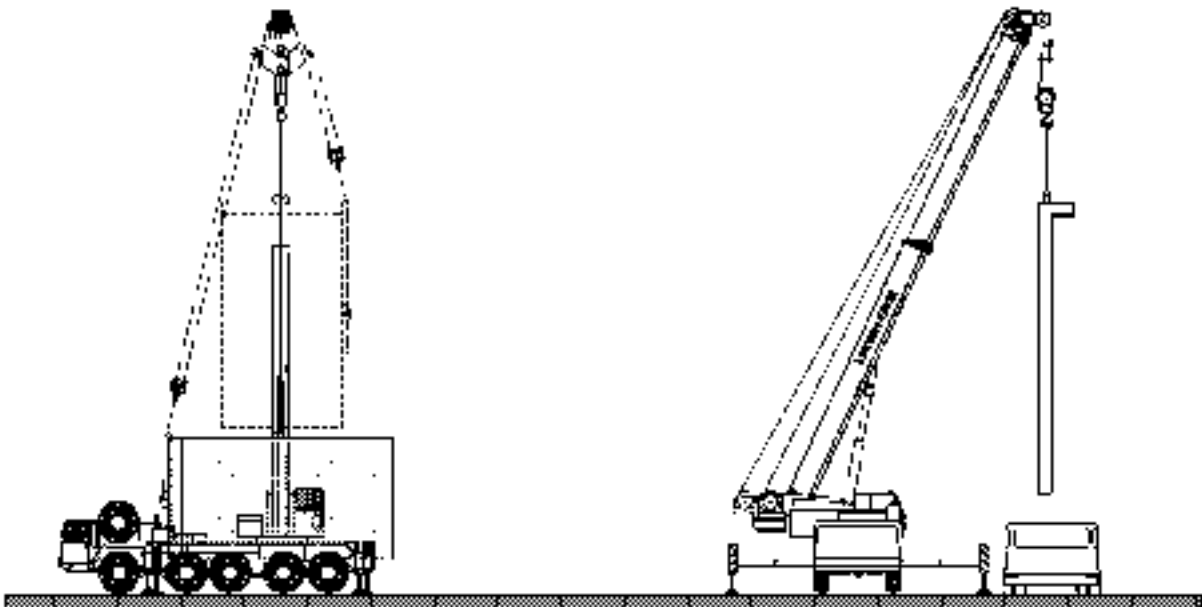

Va. 3

3. Load turning device *

The load turning device (Va.3) is a special device and is not included in delivery with the crane.

Starting up

- For two-hook operations with the load turning device, the LICCON overload safety device must be set to Tele-operations or L-mode and the present equipment mode.
- Both hooks must be quadruple-reeved.
- Cable reeving in the equipment mode diagram of the LICCON must be entered with "4".

Note: The overload safety device monitors the entire load.
The weights of the hook blocks and the slinging tackle must be added to the load to be hoisted.

DANGER: Both hook blocks must be multiply reeved. If this is not done, a hoisting gear can be overloaded.

* Special equipment

Chapter 5

Equipment

Notes on assembly:

- The hoisting cable must be reeved in between the pulley head and hook block in accordance with the reeving plans in Chap. 4.06, for the respective load capacity table.
- The ballast must be mounted in accordance with the specifications in the load capacity tables.
- Combining and mounting the ballast must be carried out in accordance with Chap. 4.07.

D A N G E R : **For assembly works on the crane, an operationally safe assembly scaffold / working platform must be used - improvisations are prohibited. Otherwise, there is a danger of falling.**

Checking the safety measures

- Is axle suspension / axle floating locked?
- Is the load bearing capacity of the foundation sufficient?
- Are all four sliding arms and support cylinders extended to the support base as indicated in the load capacity table?
- Are the sliding arms secured with pins?
- Are the support pads secured?
- Is the crane horizontally aligned?
- Is the crane at a safe distance from slopes and trenches?
- Are the axles relieved; i.e., no contact between the tires and the ground?
- Has it been absolutely established that there are not electrical wires and lines within the operating range of the crane?
- Has the operating site been selected so that operations can be carried out with the smallest possible working radius?
- Are there any obstacles which would block necessary crane movements?

Bypassing the safety devices with the assembly key-operated switch

Parts of the safety device equipment can be bypassed with the assembly key-operated switch. For certain assembly procedures, this is necessary and permissible.

D A N G E R : **Using the assembly key-operated switch during crane operations is prohibited. Only those persons may use the key-operated switch who are fully familiar with the entire operation of the crane and who are aware of the effects of bypassing the system.**
After all assembly work has been carried out, the key must be removed immediately and handed over to an authorized person.
If the load torque limiter is bypassed during crane operations, there is the danger of accidents.

Checking the cables

Before assembly and at regular intervals, the cables must be subjected to expert inspection in order to recognize possible damage and signs of wear.

D A N G E R : **The cables must be taken off the crane immediately if any of the following defects are found:**

- **broken strand**
- **broken wires**
- **groups of broken wires**
- **cable diameter 10% or more narrower than the nominal value**
- **cable deformation**

New cables must be of the same design, strength rating and diameter as the old ones. After installing a new cable, the cam limit switch in the hoisting gear must be reset.

C A U T I O N : **If the cable pulleys are rewound, they must be wound out or replaced before replacing an old cable with a new one. Otherwise, the new cable can be damaged.**

Connecting or removing hydraulic lines with quick-release couplings

D A N G E R : When connecting or removing hydraulic lines by means of the quick-couplers, it must always be ensured that the coupling procedure is carried out properly.

Requirement for a correct coupling connection is:

- Before any connections are made or loosened, there must be no pressure in the entire pressure system. (Bring engine to a standstill - wait 5 minutes)
- Assemble the coupler parts (socket and plug) and tighten with hand nut.
- Turn the hand nut until a noticeable, fixed stop is reached.
- The couplers must only be attached and detached by hands - do not use tools as this could damage the couplers.

D A N G E R : Improperly connected couplers could lead to a loss of pressure or sudden leaks and thus lead to an accident.

Raising / Lowering

Before raising or lowering a boom combination, the following requirements must be fulfilled:

Requirements:

- The crane is properly supported and horizontally aligned.
- The ballast is attached to the slewing platform in accordance with the load capacity table.
- The telescopic boom is completely retracted.
- The jib is assembled in accordance with the load capacity tables and instruction manual.
- All limit switches are correctly mounted and properly functioning.
- All pinned connections are secured.
- The hoist cable is properly placed in the cable pulleys and is secured with cable retaining pins against jumping out.
- There are no loose parts on the telescopic boom or jib.

In winter:

- The telescopic boom and the TA strut and its components (limit switch, cable drum, aircraft warning light, wind speed gauge, etc.) are free of snow and ice.

D A N G E R : Incorrectly mounted or nonfunctioning limit switches as well as falling parts (pins, spring keepers, ice, etc.) are dangerous and can cause serious injury.

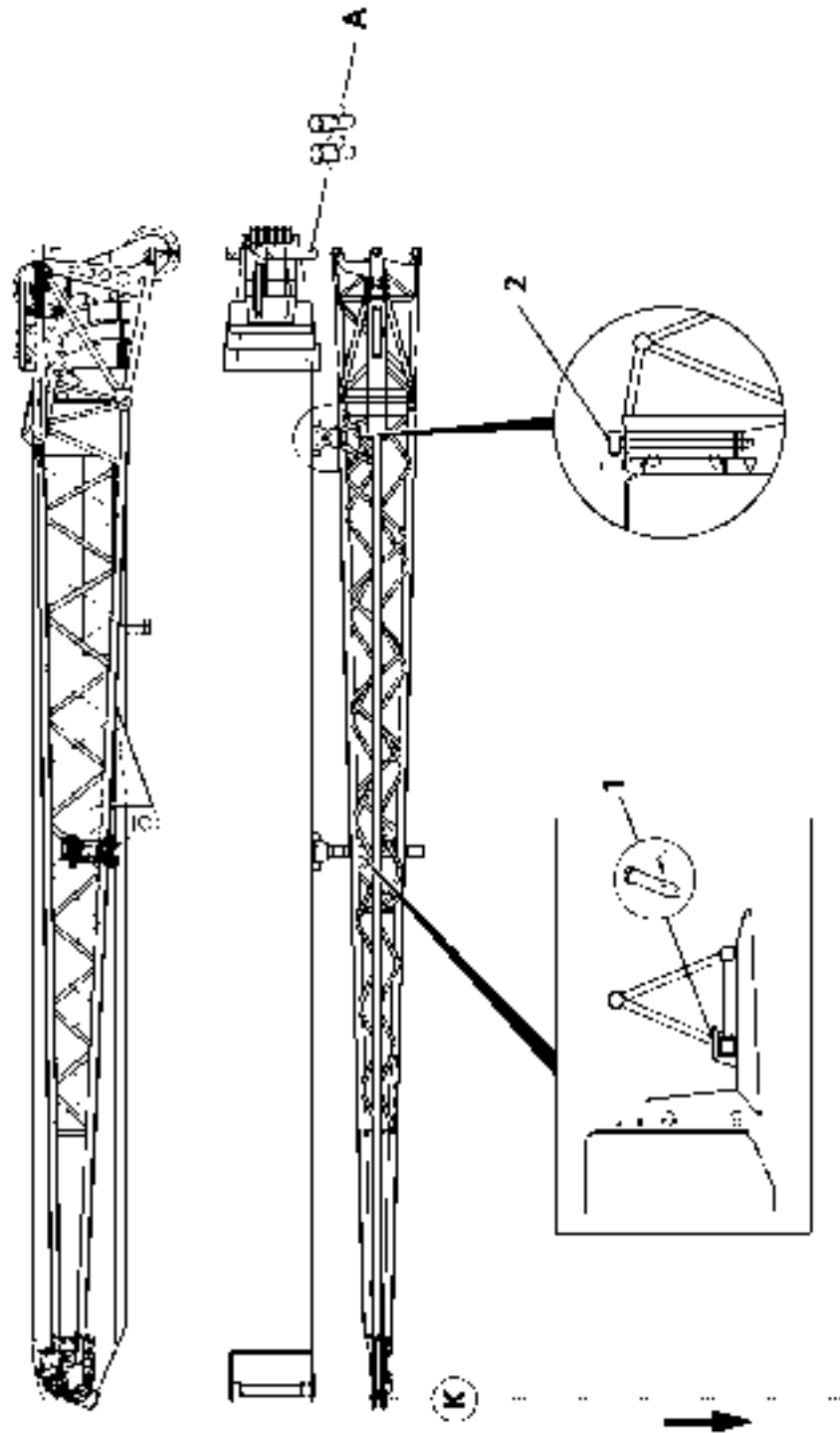

180229
LTL 1025
LTM 1025
LIM 1040

Description

The folding fly jib is composed of 1 section and can be operated at a **working length** of **8.2 m** on the 24.2 m or 26.0 m extended telescopic boom.

It can either be mounted as a straight extension or at an angle of 15° or 30° to the telescopic boom.

Assembly

DANGER: For all assembly work, an operationally safe assembly/working platform must be used. Improvisations are prohibited.
There is a danger due to the risk of falling.

Requirements:

- The crane is properly supported and horizontally aligned.
- The ballast is mounted to the slewing platform.
- The telescopic boom is fully retracted.
- The folding fly jib is attached in its transport position on the telescopic boom pivot section.
- The telescopic boom is facing to the rear, or luffed to the side at 0°.

Note: Angle indicator 0°; refer to operating and display unit of the "LICCON" overload safety device.

DANGER: The telescopic boom must be in the 0° position, as otherwise there is the danger that the folding fly jib could swing out by itself when locking is removed.

1. Assembly of the 8.2 m folding fly jib

- With the appropriate CODE number and hoisting cable reeving, set the load torque limiter to crane operation "*Crane supported, with 8.2 m folding fly jib*" (see separate "LICCON" operating instructions). The 2-place CODE number can be taken from the load capacity table.
- Attach the auxiliary rope onto the head piece (K) of the folding fly jib.
- Remove pin (1) from transport locking after removing spring keeper, and keep ready.
- Swing the folding fly jib around pivot pin (2) until (A), top and bottom, can be pinned.
- Insert both pivot pins (A) and secure with spring keepers.

DANGER: All pins must be secured. Otherwise, there is the danger of parts of the crane falling or of the folding fly jib swinging down during crane operations.

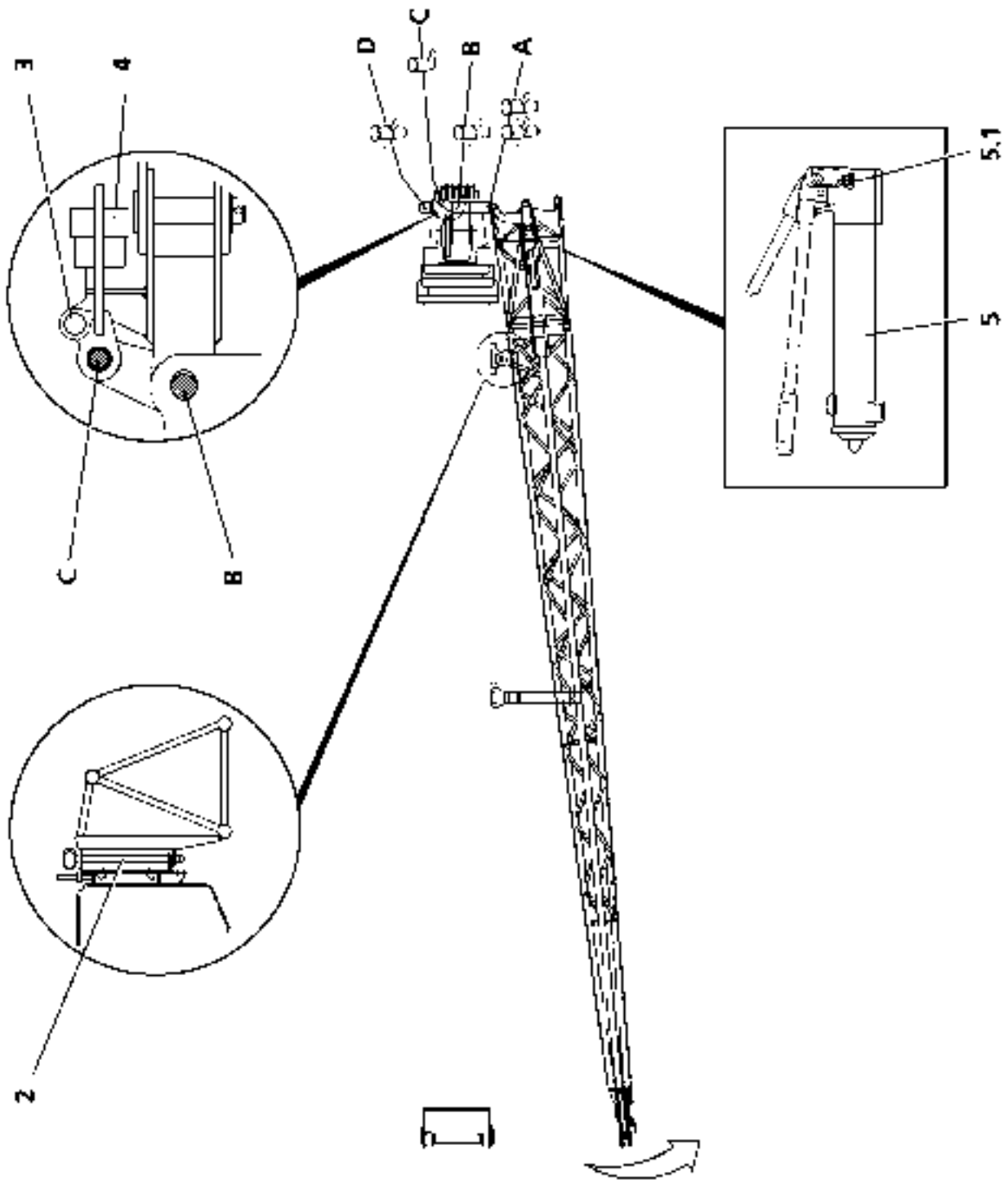

LT L 1025
LTM 1025
LIM 1040
180231

Assembly, continued**Swing the folding fly jib forward**

CAUTION: For units with narrow driver's cab, the folding fly jib must be raised somewhat before being swung forward (ca 150 mm).
If this is not done, the right-hand outside mirror may be damaged. To avoid this, mounting the folding fly jib with the boom to the side or to the rear is recommended.

- Remove pivot (2) pin after removing spring keeper.

DANGER: When removing the pivot pin (2), the folding fly jib must be held with the auxiliary rope in order to prevent it from swinging out.

- With the aid of the auxiliary rope, swing the folding fly jib out enough so that pivot pin (2) can be reinserted in the holder on the boom pivot section and secured with a spring keeper.
- With the auxiliary rope, swing the folding fly jib 180° until it can be pinned at (D).
- Insert pin at (D) and secure with spring keeper.

DANGER: There must be no persons or objects within the swinging range of the folding fly jib - there is a danger of injury or accident.

In order to pin at (B), after removing the spring keeper of pin (3), the pin must be reinserted on the pressure cylinder (4) and secured with a spring keeper.

The pressure cylinder (4) is then activated with hand pump (5) until the bore holes on the eye of the folding fly jib and on the boom head are even with each other.

Insert a pin at (B) and secure with a spring keeper.

CAUTION: If all pins (2x at A, 1 each at B and D) are inserted and secured, the load on the pin in hole (C) must be relieved by opening the valve (5.1) on the hand pump (5).

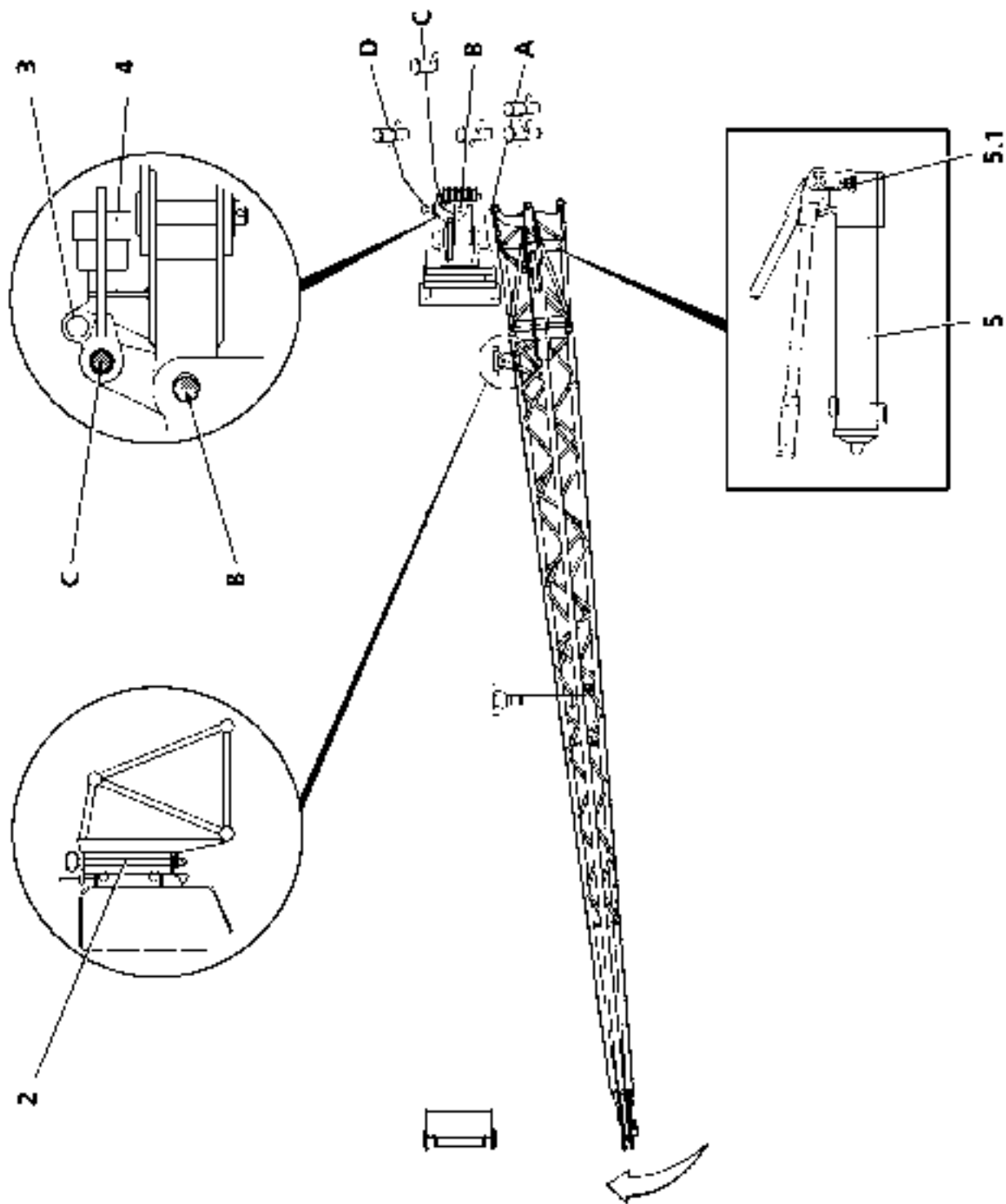

LT L 1025
LTM 1025
LIM 1040
180232

Disassembly

DANGER: For all assembly work, an operationally safe assembly/working platform must be used. Improvisations are prohibited. Otherwise there is a danger of falling off the platform.

Requirements:

The crane is properly supported and horizontally aligned.

The ballast is mounted to the slewing platform in accordance with the load capacity table.

The telescopic boom is fully retracted.

The folding fly jib is pinned in the 0° position.

The telescopic boom is facing to the rear, or luffed to the side at 0°.

An auxiliary rope is attached to the head piece on the jib.

Note: Angle indicator 0°; refer to operating and display unit of the "LICCON" overload safety device.

DANGER: The telescopic boom must be in the 0° position, as otherwise there is the danger that the folding fly jib could swing out by itself when locking is removed.

CAUTION: For units with narrow driver's cab, swinging back the folding fly jib may damage the right-hand outside mirror. To avoid this, mounting the folding fly jib with the boom to the side or to the rear is recommended.

- Remove both pins (D and B), insert into the holders provided and secure with spring keepers.

Note: In order to relieve pin (B) when removing it, the hand pump (5) of the pressure cylinder (4) must be operated until the bore holes on the eye of the folding fly jib and on the boom head are even and pin (B) can be removed.
The pin in hole (C) must be relieved of its load by opening the valve (5.1) on the hand pump (5), reinserted in hole (3) and secured with a spring keeper.

DANGER: Both pivot pins (A) must remain inserted and secured. While unpinning the folding fly jib from the telescopic boom (pins D and B), the jib must be held by the auxiliary rope to prevent it from swinging out by itself.

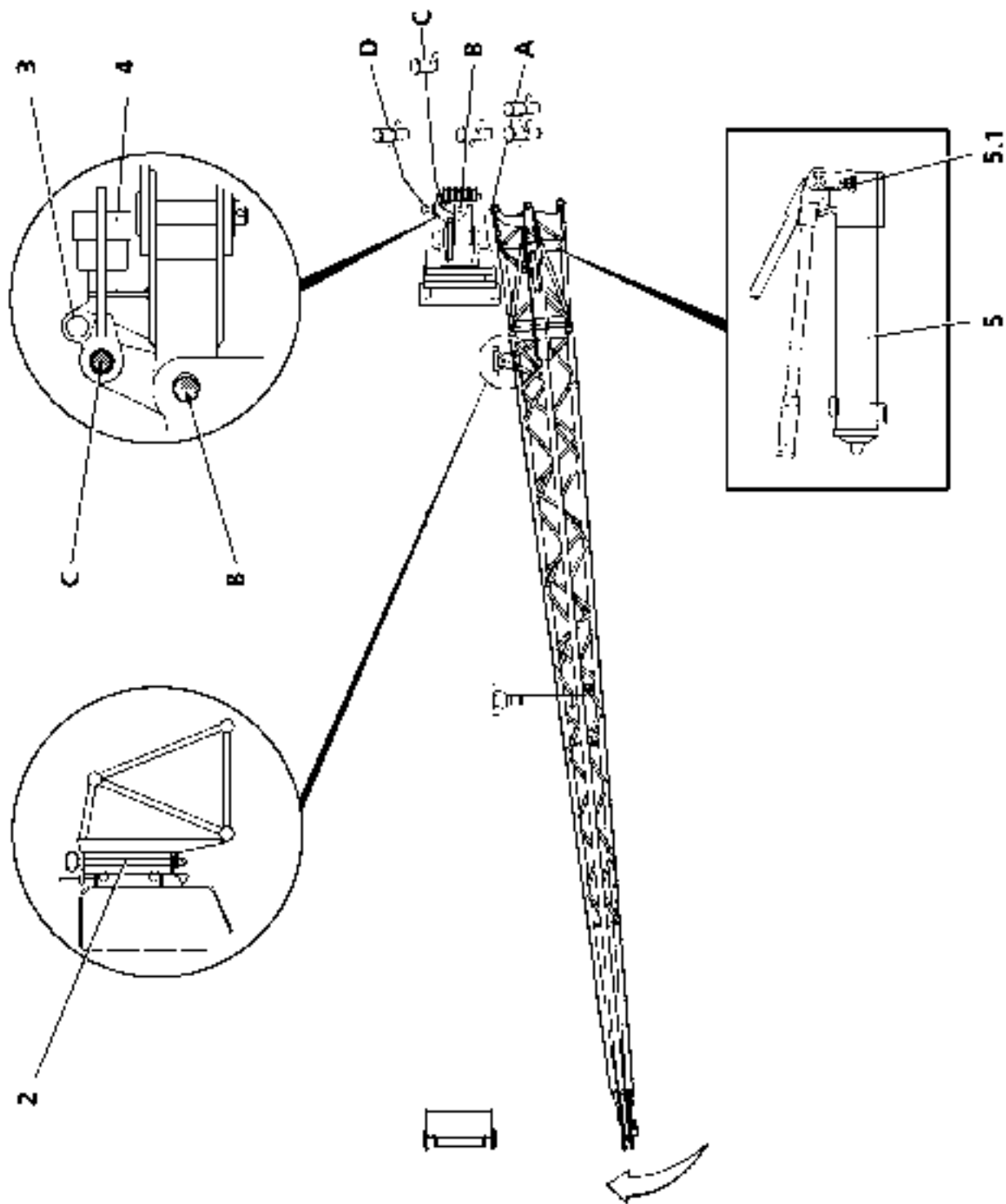

180232
LTL 1025
LTM 1025
LIM 1040

Disassembly, continued

- With the auxiliary, swing out the folding fly jib 180° until the pivot pin (2) can be inserted at the pivot point.
- Insert pivot pin (2) and secure with a spring keeper.

D A N G E R: **There must be no persons or objects within the swinging range of the folding fly jib - there is a danger of injury or accident.**

- Remove both pivot pins at (A), insert into the holders provided, and secure with spring keepers.
- Swing folding fly jib around pivot point (2) to the pivot section until pin (1) can be inserted in the transport locking.
- Insert pin (1) and secure with spring keeper.
- Remove auxiliary rope and stow.

D A N G E R: **All pins must be secured - otherwise, accidents could be caused by falling crane components!**

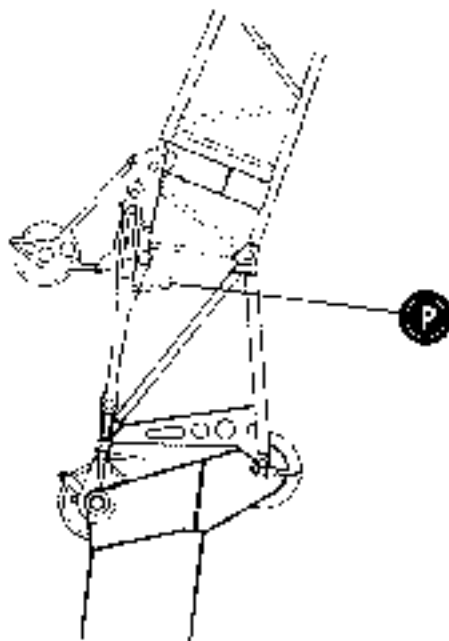
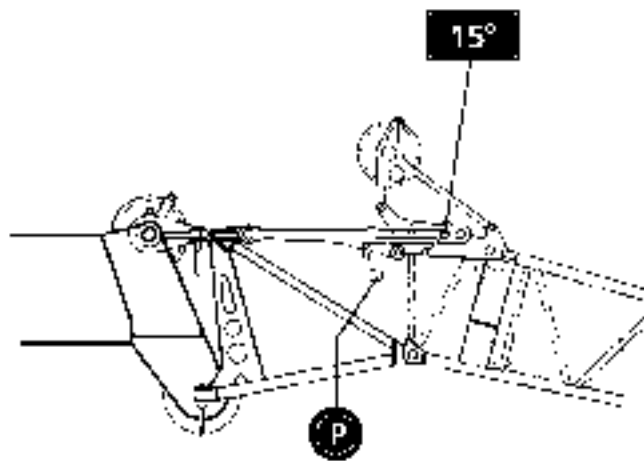
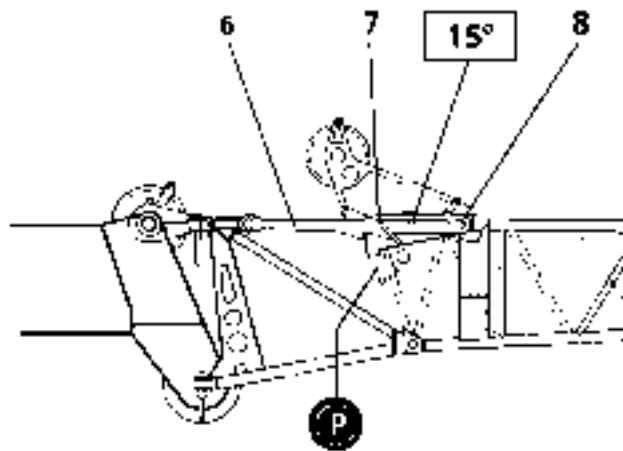

LTL 1025
LTM 1025
LTH 1040

180233

2. Assembly of the 8.2 m folding fly jib below an angle of 15° to the telescopic boom.**Requirements:**

The folding fly jib is mounted as a straight extension in 0° position as described in paragraph 1.

The crane is correctly supported and horizontally aligned.

The telescopic boom is swung to the rear or to the side.

Assembling at an angle of 15°

- Extend and completely lower the telescopic boom until the head piece of the folding fly jib touches the ground.

Note: If necessary, provide a foundation for the head piece/pivot section.
It may be necessary to diagonally adjust the supported crane.

- Remove pin (8), place into its rest and secure with a spring keeper.
- Remove pin (7), raise shackle (6) slightly, insert pin (7) into the corresponding hole for 15° and secure with a spring keeper.

If the crane has been diagonally adjusted, it must now be horizontally aligned once again.

Notes on raising the 15° folding fly jib

When raising, the pendulum (P) swings automatically into the retention locking.

D A N G E R : Before raising, the pendulum (P) must be checked to make sure that it swings freely and smoothly through its entire range.
If this is not done and the pendulum does not operate correctly, the retention locking can fail during strong wind from the front or if the load tears free.

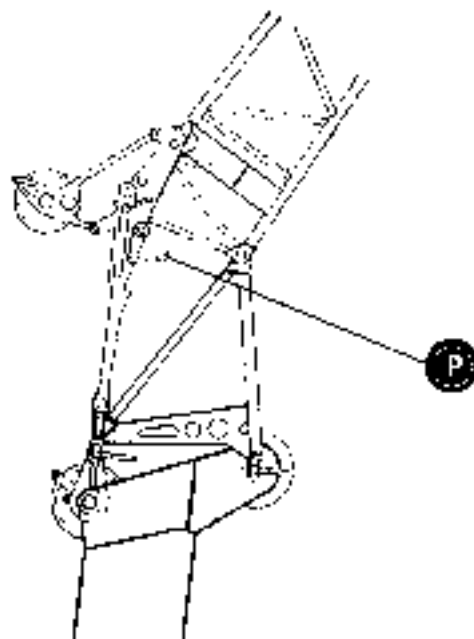
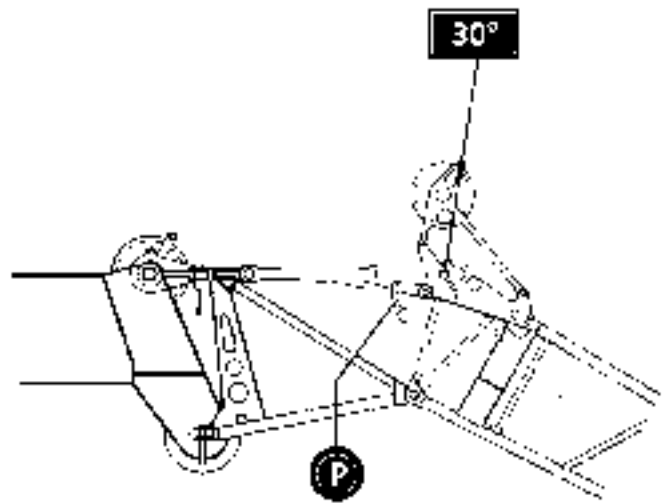
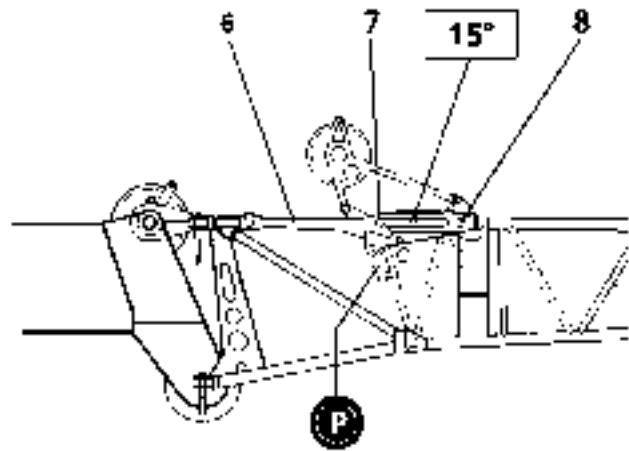

LTL 1025
LTM 1025
LTM 1040

180234

2. Assembly of the 8.2 m folding fly jib below an angle of 30° to the telescopic boom.**Requirements:**

The folding fly jib is mounted as a straight extension in 0° position as described in paragraph 1.

The crane is correctly supported and horizontally aligned.

The telescopic boom is swung to the rear or to the side.

Assembling at an angle of 30°

- Extend and completely lower the telescopic boom until the head piece of the folding fly jib touches the ground.

Note: If necessary, provide a foundation for the head piece/pivot section.
It may be necessary to diagonally adjust the supported crane.

- Only remove pin (8), place into its rest, and secure with a spring keeper.

CAUTION: Pin (7) must NOT be removed.

If the crane has been diagonally adjusted, it must now be horizontally aligned once again.

Notes on raising the 30° folding fly jib

When raising, the pendulum (P) swings automatically into the retention locking.

DANGER: Before raising, the pendulum (P) must be checked to make sure that it swings freely and smoothly through its entire range.
If this is not done and the pendulum does not operate correctly, the retention locking can fail during strong wind from the front or if the load tears free.

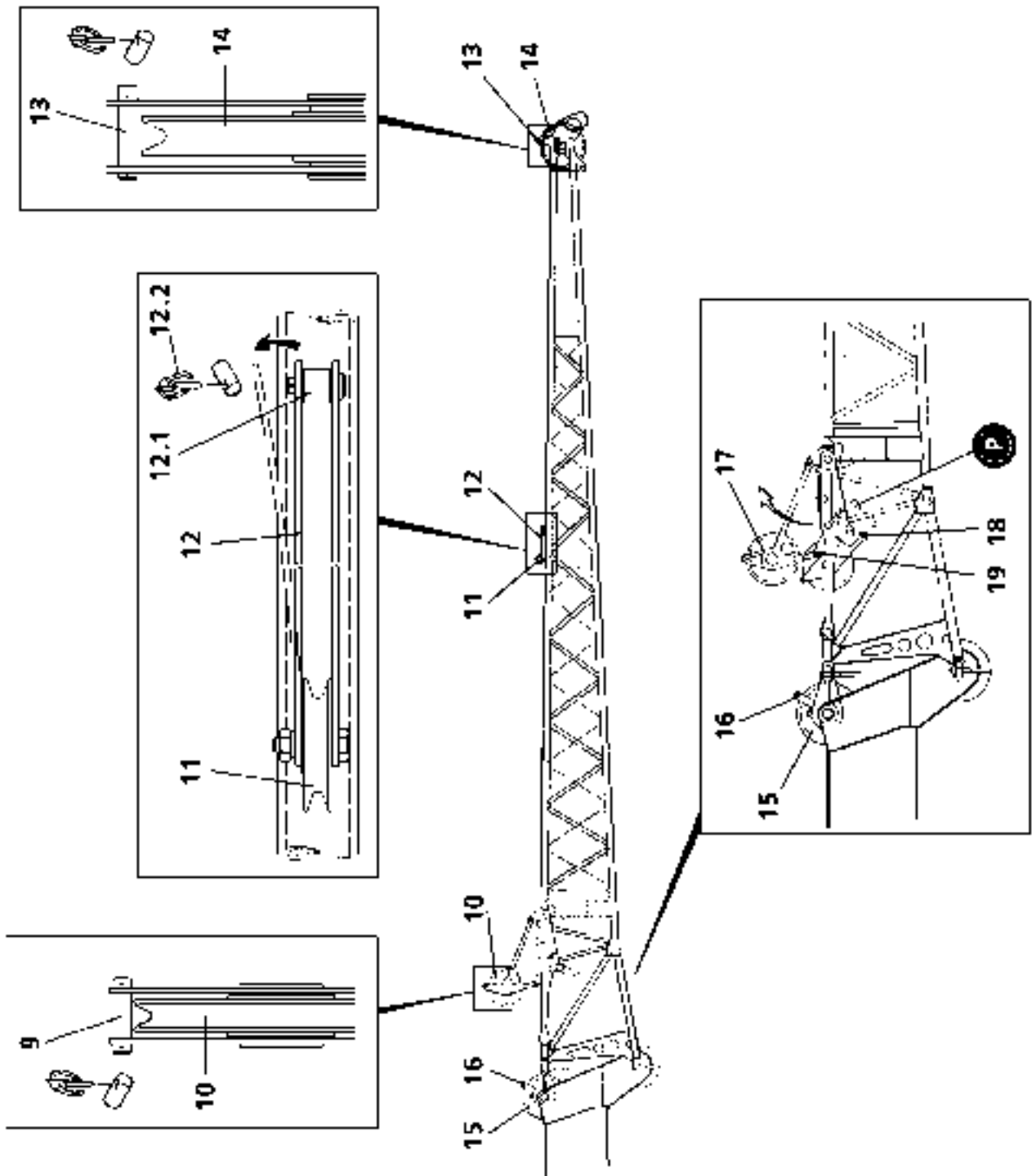

180236
LTL 1025
LTM 1025
LIM 1040

3. Hoisting cable reeving on the 11.3 m long folding fly jib

Requirements:

Swing the cable pulley (17) out of the "lower" into the "upper" transport position in the operating position. Insert pin (18) in hole (19) and secure with spring keeper.

Use of the winch 1 hoisting cable on the folding fly jib

- Remove cable retaining pins (9, 13, and 16).
- Lay hoisting cable over cable pulley (10), beside cable guide (11) and over cable pulley (14).
- On the cable guide (11), after removing the spring keeper (12.2), pull the shackle (12) far enough out that the hoisting cable can be laid behind the shackle (12) onto pin (12.1).
- Replace shackle (12) onto pin (12.1) and secure with spring keeper (12.2).
- Reinsert cable retaining pins (9, 13, and 16) and secure with spring keepers.
- Reeve the load hook on the hoisting cable or the hoisting cable into the hook block and in cable socket and secure.
- Attach hoist limit switch.

Use of the winch 2 hoisting cable on the folding fly jib

- Remove cable retaining pins (9, 13 and 16).
- Lay hoisting cable over cable pulley (10), through cable guide (11) as described above and over cable pulley (14) on the folding fly jib.
- Reinsert cable retaining pins (9, 13 and 16) and secure.
- Reeve the load hook on the hoisting cable or the hoisting cable into the hook block and in cable socket and secure.
- Attach hoist limit switch.

CAUTION: If the hook block on the telescopic boom remains reeved in, cable retaining pin (16) on the back pulley of the boom head must not be removed.

If operations are carried out over the folding fly jib with the hoisting cable of winch 2, reeving out the hook block on the telescopic boom is not required.

CAUTION: In this case, the load capacity on the folding fly jib is reduced in proportion to the weight of the reeved hook block.

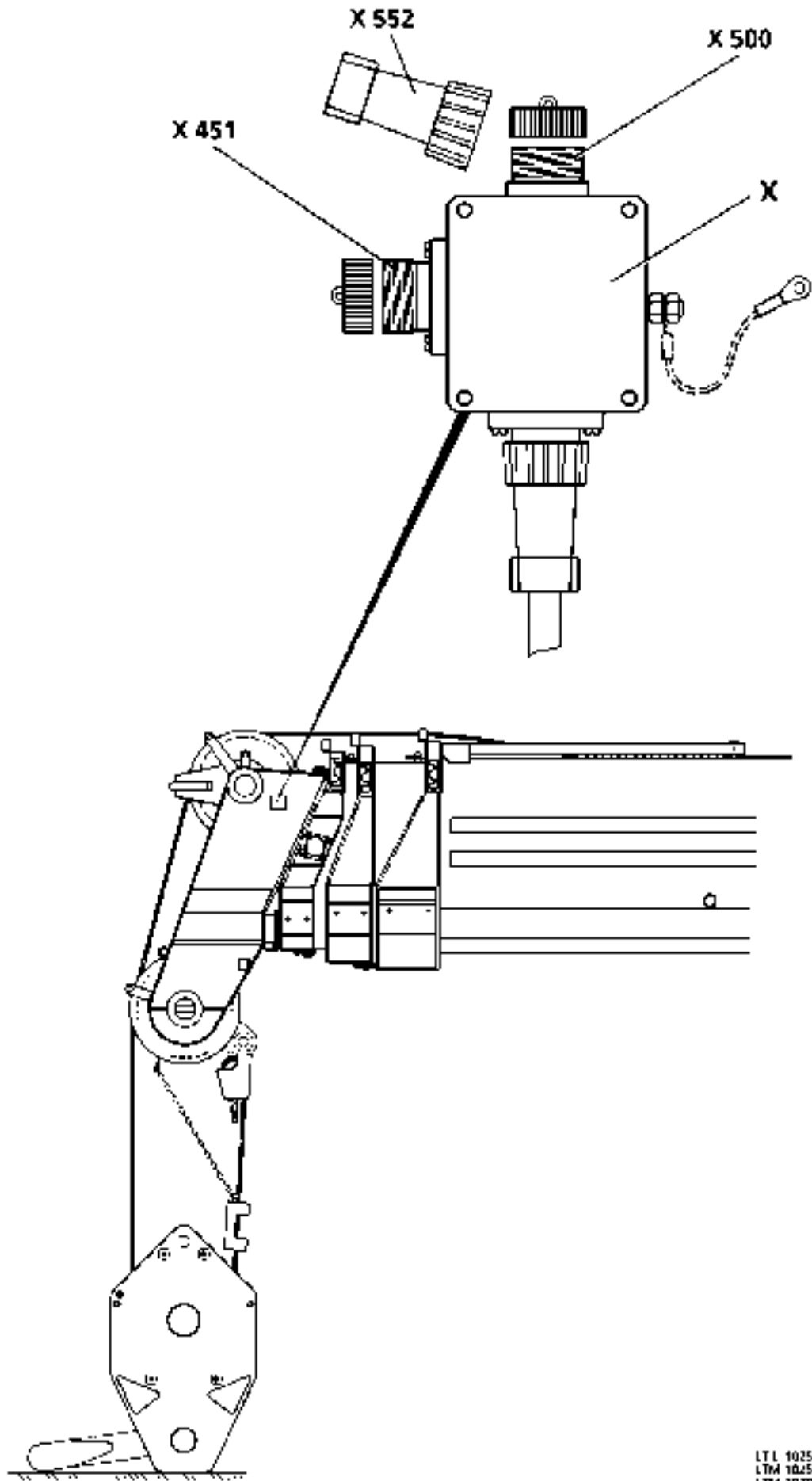

LTL 1025
LTM 1025
LTM 1070
180237

4. Attaching the hoist limit switch (HES)

One-hook operations

- On the terminal box **X** (left side of the telescopic boom), remove the plug from socket **X 451** of the telescopic boom hoist limit switch cable after loosening the sleeve nut.
- Insert the dummy plug **X 552** of socket **X 500** into socket **X 451** and secure with sleeve nut.
- Insert the plug of the hoist limit switch of the folding fly jib into socket **X 500** and secure with sleeve nut.
- Attach hoist limit switch.

Two-hook operations

CAUTION: For two hook operation, the dummy plug **X 552** must be removed and the plug of the folding jib hoist limit switch cable must be connected to socket **X 500**.

Disassembly

- Reinsert dummy plug **X 552** into socket **X 500** and the limit switch plug of the telescopic boom into socket **X 451**, secure with sleeve nut.

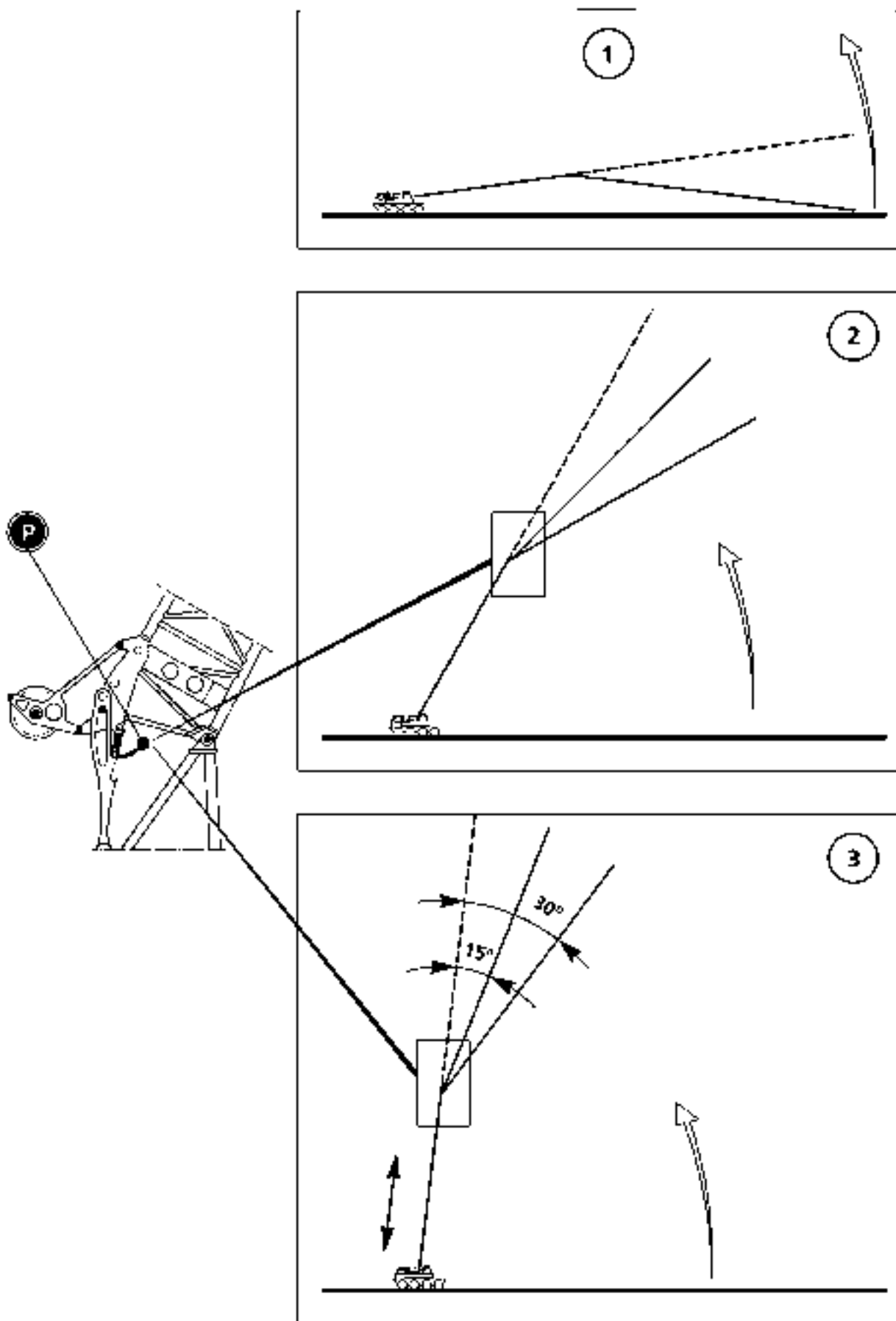

Raising

Requirements:

The crane is properly supported and horizontally aligned.

The ballast is mounted to the slewing platform in accordance with the load capacity table.

The telescopic boom is fully retracted.

The folding fly jib is assembled in accordance with the load capacity table and operating instructions.

All limit switches are correctly attached and fully functional.

All pinned connections are secured.

The hoisting cable is properly placed in the cable pulleys and secured against jumping out with the cable retaining pins.

There are no loose objects on the telescopic boom and folding fly jib.

In winter:

The telescopic boom and the folding fly jib and associated components (limit switch, cable drum, aircraft warning light*, wind speed gauge*, etc.) are free of snow and ice.

DANGER: **Incorrectly mounted or nonfunctioning limit switches as well as falling objects (pins, spring keepers, ice, etc.) pose a serious danger and could lead to accidents.**

Raising procedure

- Set the "LICCON" overload safety device in accordance with the load capacity table to 0°, 15° or 30° operation and confirm.
- Enter operating mode TK.

Raising

- Luff the folding fly jib until the head piece raises from the ground.
- Reeve the hoisting cable between the pulley head on the head piece and the hook block and secure on cable socket.
- Attach hoist limit switch.
- Luff the telescopic boom with the mounted fly jib to the **lowest** operating position (Figure 2).

DANGER: **The working radii specified in the load capacity table must be strictly adhered to, even without a load! If the working radius is less than that indicated or is exceeded, the crane could topple over.**

* Optional

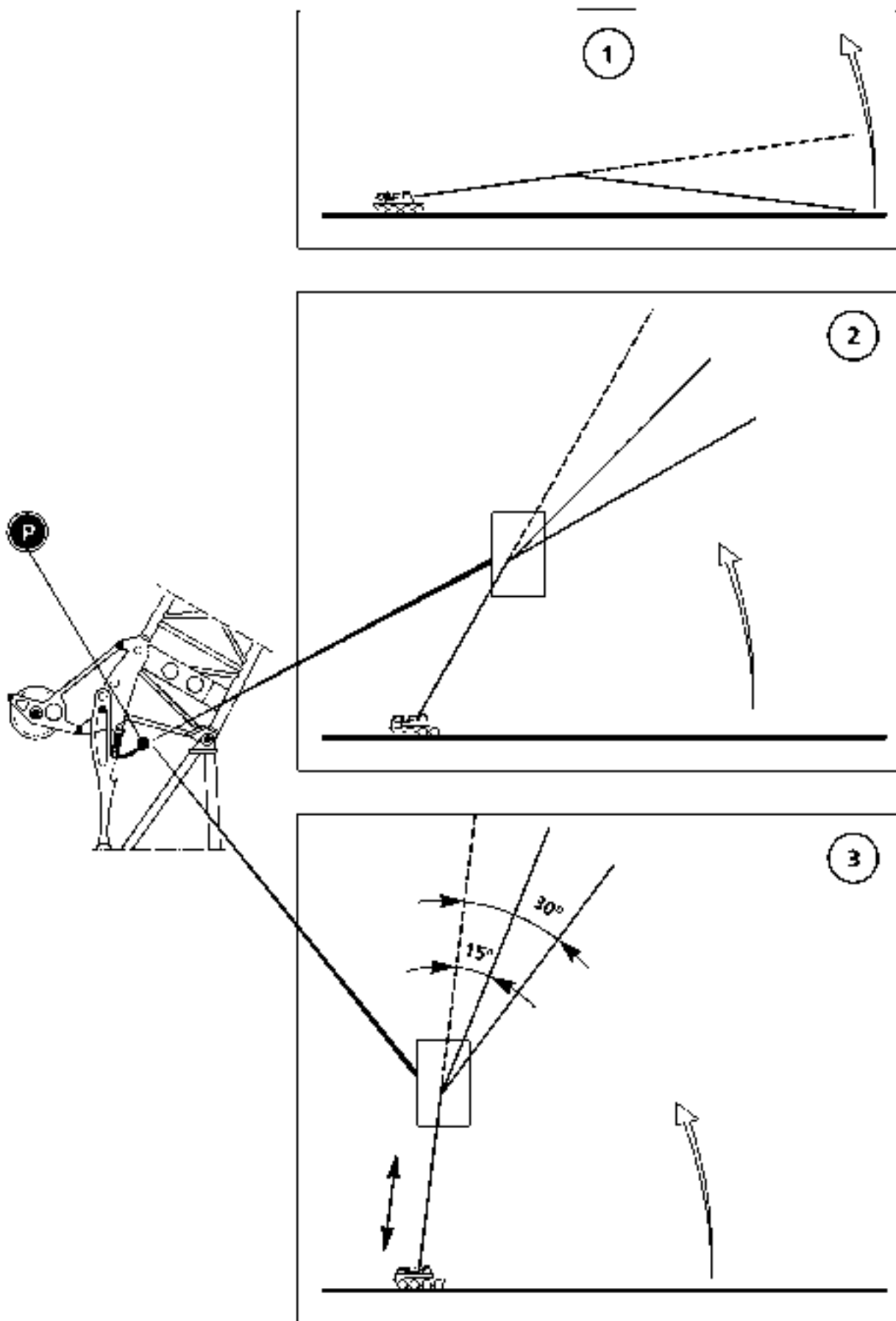

Raising, continued

- Luff the telescopic boom to the steepest telescopic boom position of 83°.
- Extend the boom to the telescopic boom length as specified in the load capacity table.

D A N G E R: **Extending or retracting the telescopic boom with the folding fly jib attached is only permissible at the steepest telescopic boom position (83°).
There is danger of accidents occurring!**

Note on raising the folding fly jib below an angle of 15° or 30°.

When raising, the pendulum (P) swings automatically into the retention locking.

D A N G E R: **Before raising, the pendulum (P) must be checked to make sure that it swings freely and smoothly through its entire range.
If this is not done and the pendulum does not operate correctly, the retention locking can fail during strong wind from the front or if the load tears free!**

Use of aerial platforms on Liebherr telescopic cranes

Issued according to the ‘Safety Regulations for Aerial Personnel Platforms’, issued by the Hauptverband der gewerblichen Berufsgenossenschaften (German Trade Union Association), Id. No. ZH 1/461, Issue 10/89.

The following is an example for the use of an aerial platform with a total weight of 650 kg (1433 lbs.), a utility load of 360 kg (794 lbs.) and a dead weight of 290 kg (639 lbs.):

1. The responsible crane operator as well as any personnel responsible for the crane operation with the aerial platform must know the above mentioned safety regulations and must have received special instructions regarding these regulations.
 - 1.1 The trade union must be notified in writing before the first operation of the crane with an aerial platform.
 - 1.2 Before the first operation, after any construction changes, repairs, and as necessary, but at least once a year, the installation (the lifting device with aerial platform) must be checked by expert, authorized personnel.
 - 1.3 The work platform, which is to be used, is subjected to certain requirements (see paragraph 5 to 5.9). Therefore, only an approved aerial or work platform may be used.
 - 1.4 A supervisor, who is familiar with all guidelines and regulation and who is monitoring the application, must be appointed or designated .
 - 1.5 Before any use, the safety devices of the crane must be checked for proper function; this applies especially to the hoist limit switch and the load momentum limitation. However, all other crane functions must also operate properly.
 - 1.6 The crane operator may not leave the crane's cab when the aerial platform is occupied, the operating levers must remain in zero position.
 - 1.7 Crane speeds, measured on the top of the boom, may not exceed 0.5 m/s (30 m/min). Since the maximum cable speed is up to 120 m/min, a 2 - sheave reeving is required. During aerial platform operation, the engine speed must be reduced to 1000 RPM (high idle), from a maximum engine RPM of 2100 RPM. However, if the reeving number is (higher than) ≥ 4 , the full engine speed may be utilized.
 - 1.8 It is only permitted to work in an aerial platform within a range, where the permissible load carrying capacity is at least 1.5 times the value of the total weight of the platform.
For the aerial platform above, this value would be: $1.5 \times 650 \text{ kg} = 975 \text{ kg}$ (2150 lbs).
The crane with the work or aerial platform may **not** be operated while **”freestanding on tires”**.

D A N G E R : **If these points are not being observed, the danger of having an accident is greatly increased!**

Requirements on the lifting device for operation with aerial platform

2. The requirement, which must be met by lifting devices for the operation of an aerial platform are met by Liebherr telescopic cranes with standard attachments as follows:
 - 2.1 The lifting devices correspond to prerequisites set by the trade union, the cable drives are set according to DIN 15020.
 - 2.2 The calculation and minimum breaking load values of the hoist cables are entered in the crane's board book. The personnel platform must be attached by the operator in such a way that the cable safety is at least 10 - fold.
 - 2.3 All hoisting cables must have a diameter of at least 8 mm and must be a stressfree type.
 - 2.4 The hoist winches are power driven, with powered "down" operation without free - fall device, can be controlled steplessly and permit output speeds below 0.5 m/s (1.6 ft. per second). Due to spring force, the control levers move into zero position when released. The brakes are self - acting.
 - 2.5 The upward movement is limited by an emergency limit switch, designed according to regulations which must be checked before every operation.
 - 2.6 The hoist cable must be mounted properly in the cable mount. It may not hook and conflict with the hoist limit switch installation.
 - 2.7 All cable rollers are fitted with cable protection .
 - 2.8 A device, which would make it possible to return the aerial platform into initial position in case of an power failure is not part of a standard equipment. For this reason, an external source can be connected, if necessary.
3. **Liebherr** telescopic cranes are designed for operation with aerial platforms and exceed the safety regulations set for lifting devices with the following items , such as
 - integrated shut off valves in all load carrying hydraulic cylinders, which fulfill the function of load check valves in case hydraulic pipe rupture.
 - with self acting, generously dimensioned hoist gear brakes .
 - with automatic load moment protection.

Chapter 6

Additional Equipment

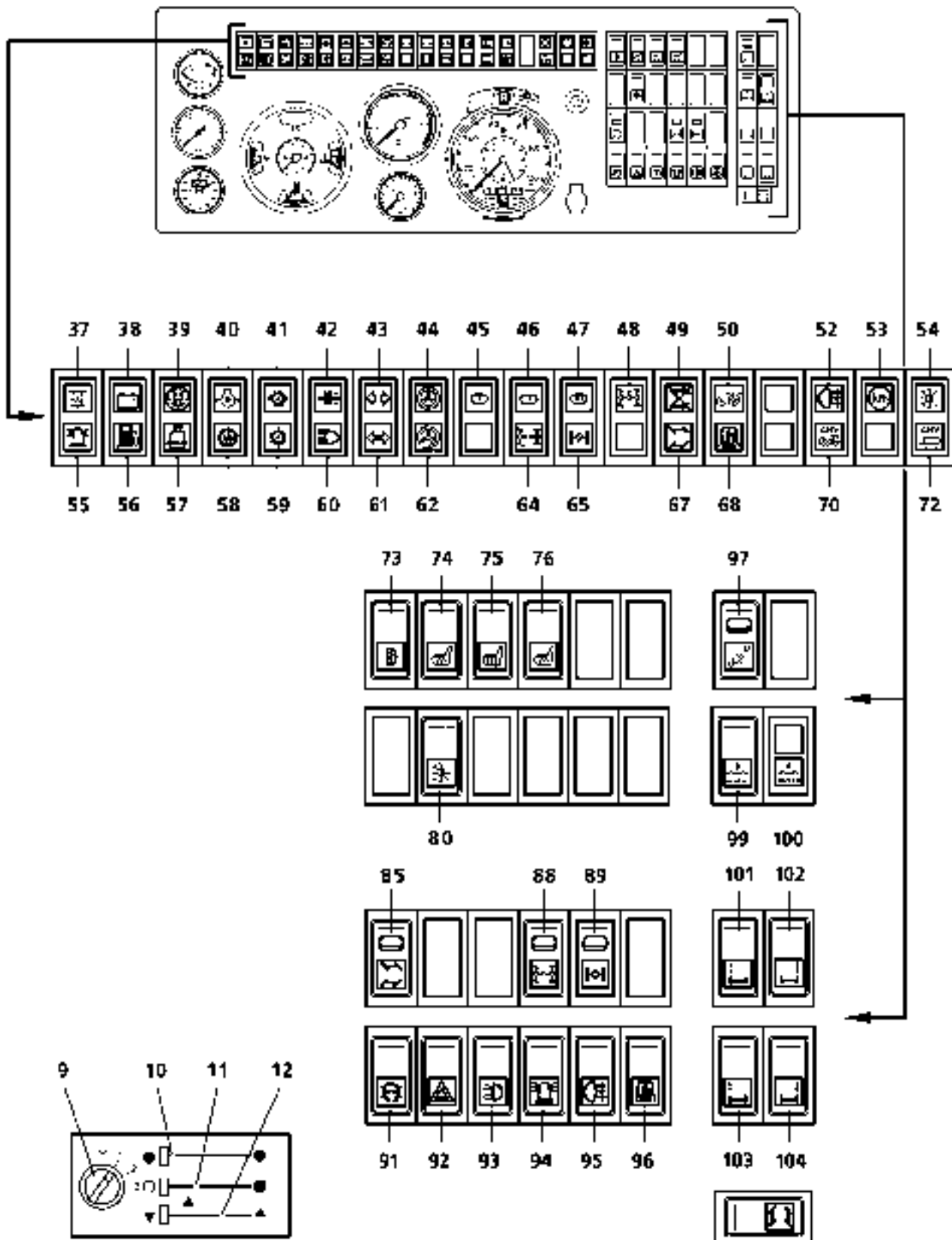

Heating system - crane chassis

1. **The driver's cab can be heated with two ¹⁾ heating systems, which operate independently from each other .**

1.1 **Engine dependent heater**

The heat for the driver's cab is supplied by the engine coolant, it can be regulated via the temperature regulator (10) and can be used to heat the cab.

Via regulator (11) , you can choose between fresh air or air circulation.

The air distribution to the top or bottom can be preselected via the regulator (12) .

Via a 3-stage blower switch (9), the heated air flow can be regulated.

1.2 **Engine independent WEBASTO auxiliary heater ¹⁾**

Refer to the manufacturer's Operation Manual for the WEBASTO auxiliary heater for more detailed information .

The engine independent heater is used to preheat the Diesel engine, as well as to heat the driver's cab if the engine is not running and as an auxiliary heating system in case ambient temperatures are extremely low and the engine heating system is not sufficient.

DANGER: **The heater may not be operated in closed areas, such as garages or workshops, this includes preset timers ²⁾ or Tele start ²⁾ systems.**
If this point is not observed, you create a dangerous situation, which can cause poisoning or suffocation !

In gas stations and refueling stations, the heater must be turned off .
If this point is not observed, there is a danger of EXPLOSION!

1.2.1 **Additional heater ¹⁾ used as a heating system if the engine is not running**

- Turn the blower switch (9) to stage 1, move the temperature regulator (10) to "WARM" and turn the auxiliary heater on via switch (96), the indicator light (68) will light up.

By moving the sliding regulator (10), the amount of water can be regulated and via the blower switch (9), the air flow amount can be regulated.

1.2.2 **Preheating the engine ³⁾ with the WEBASTO auxiliary heater**

If temperatures fall below -15°C ,then the engine can be preheated with the auxiliary heater.

- To preheat the engine, move the regulator (10) for the heater in the driver's cab to "COLD" .
- Via switch (96), turn on the auxiliary heater, indicator light (68) will light up.

Now the coolant fluid for the Diesel engine is preheated via this additional heating system. It can take up to an hour, depending on the ambient temperatures.

1) 2) 3) Optional

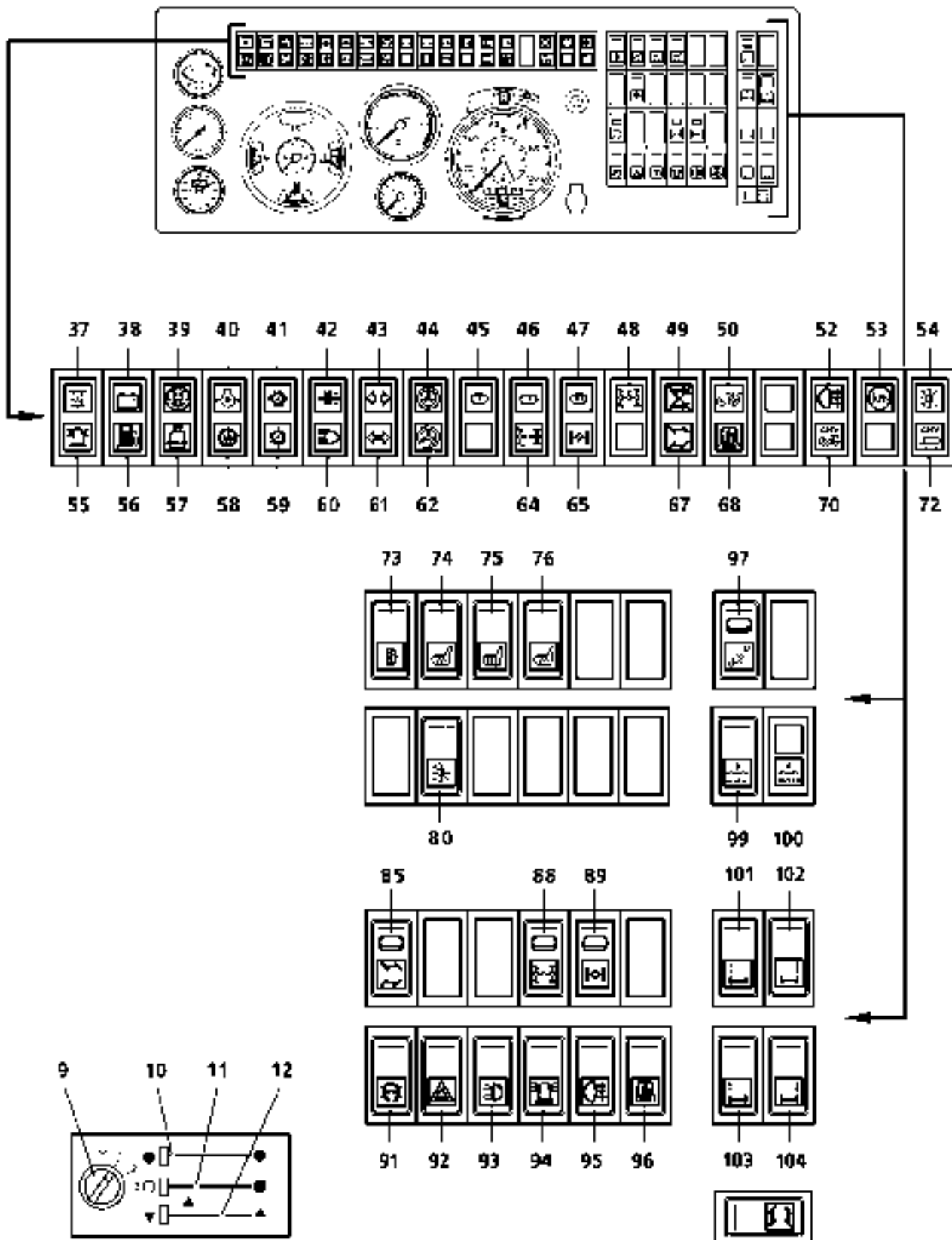

To bleed the system

When draining the engine coolant fluid, the contents of the heating system must also be drained, because the engine coolant system and heater system are part of the same single circuit.

When refilling the system, it must be bled carefully, the quickest way is to bleed the system with the engine.

- Via the expansion tank of the travel motor for the cooling system, add coolant as specified in the lubrication chart.
- Open the bleeder valve on the bleeder line of the auxiliary heater,
- start the engine as described in chapter 3.04.
- Move the temperature regulator (10) to "WARM".
- Watch the expansion tank to see if air bubbles rise up.
- If no more air bubbles are visible in the expansion tank, move the temperature regulator (10) to "COLD", this bleeds the circuit for the engine preheat system.
- If even now no more air bubbles rise in the expansion tank, then this circuit is also bled properly.

CAUTION: The bleeder valve must always be closed during crane operation!

The main battery switch (20) may only be turned off after the heater has stopped running!

If any arc welding must be done on the crane, disconnect the negative and positive cable from the vehicle and the crane superstructure batteries to protect the heater controls and attach both positive cables to the vehicle ground .

Note :

During the summer month, let the auxiliary heater (s) * run once a month for at least 15 to 20 minutes.

* Optional

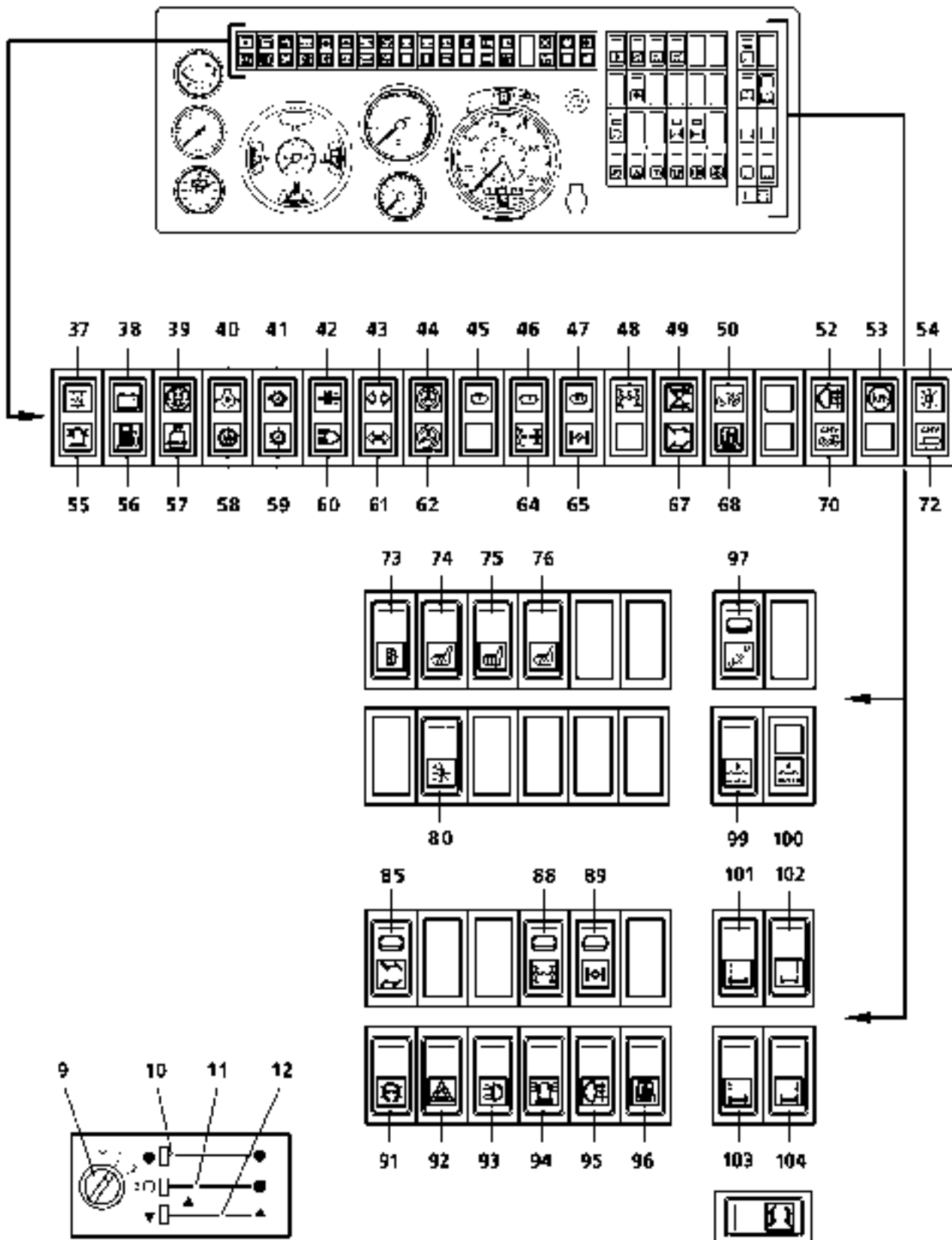

1.3 Air conditioning system *

Refer to the Operating Manual supplied by the air conditioner manufacturer for a more detailed description.

To use the system

- Turn on the main battery switch (20) and also turn on the ignition,
- close the regulator for fresh air / circulation (11).
- Turn on the air conditioning system via switch (80), the illuminated indicator light (54) shows that the system is operational.
- Preselect the air flow to the top or bottom via regulator (12),
- turn on the blower via the rotary switch (9).
- Adjust the temperature with the regulator (10).

* Optional

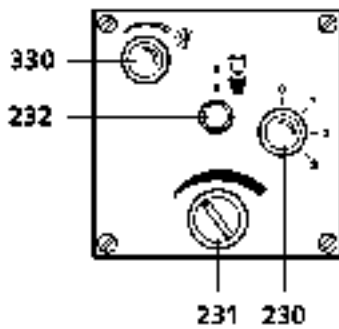
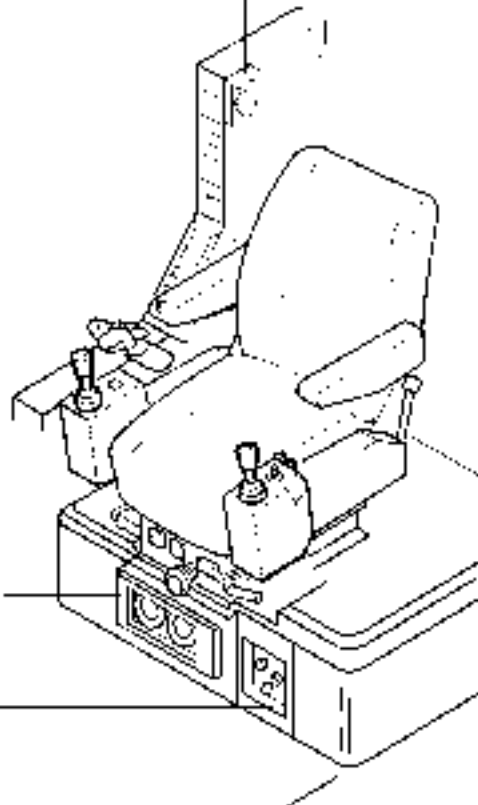
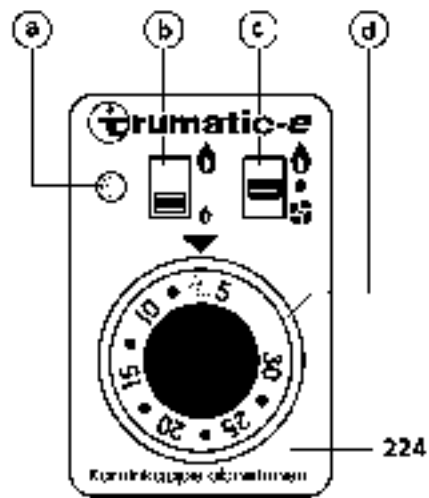
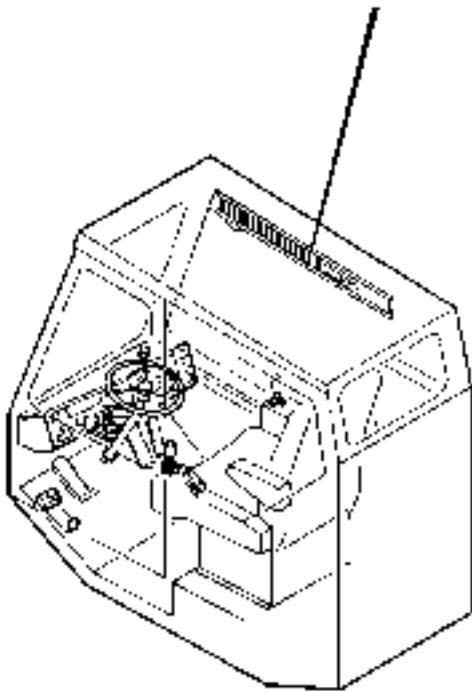
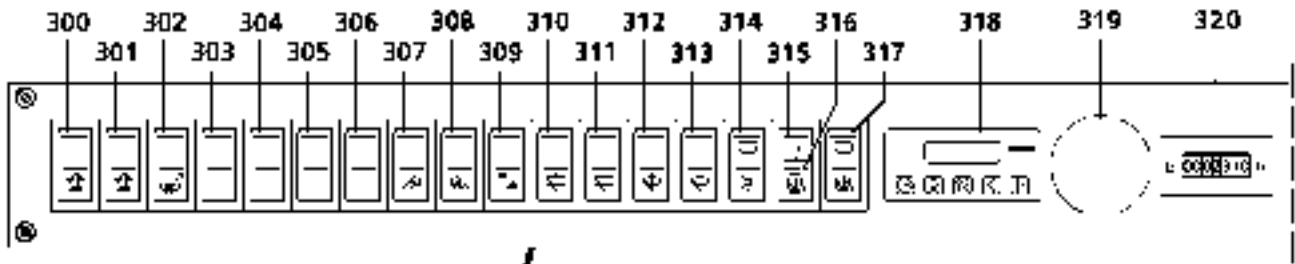

Heater - crane superstructure

2. The crane operator's cab can be heated by one heating system ¹⁾, which operates independently.

2.2 **Engine independent WEBASTO auxiliary heater ¹⁾**

Refer to the manufacturer's Operation Manual for the WEBASTO auxiliary heater for more detailed information .

The engine independent heater is used to preheat the crane's engine, as well as to heat the crane operator's cab if the engine is not running and as an auxiliary heating system in case ambient temperatures are extremely low and the engine heating system is not sufficient.

DANGER: The heater may not be operated in closed areas, such as garages or workshops, this includes preset timers ²⁾ or Tele start ³⁾ systems.
If this point is not observed, you create a dangerous situation, which can cause poisoning or suffocation !

**In gas stations and refueling stations, the heater must be turned off .
If this point is not observed, there is a danger of EXPLOSION!**

2.2.1 **Additional heater used as a heating system if the crane engine is not running.**

- Turn the blower switch (230) to stage 1,
- move the temperature regulator (231) to "WARM" and turn the auxiliary heater on via switch (317), indicator light (316) will light up.
By moving the temperature regulator valve (231), the amount of water can be regulated and via the blower switch (230), the air flow amount can be regulated.

2.2.2 **Preheating the engine ⁴⁾ with an auxiliary heater**

If temperatures fall below -15 °C ,then the engine can be preheated with the auxiliary heater.

- To preheat the engine ²⁾, move the regulator (231) to "COLD".
Via switch (317), turn on the auxiliary heater, the indicator light (316) will light up.
Now the coolant fluid for the Diesel engine is preheated via this additional heating system. It can take up to an hour, depending on the ambient temperatures.

2.2.3 **Thermostat ⁵⁾**

The desired temperature in the cab can be preselected on a thermostat.
The temperature regulator valve (231) must be set to "WARM".

1) 2) 3) 4) 5) Optional

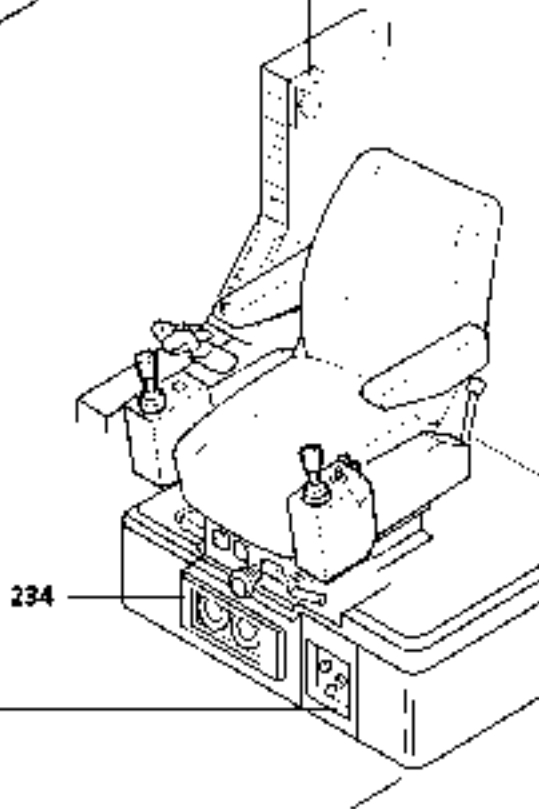
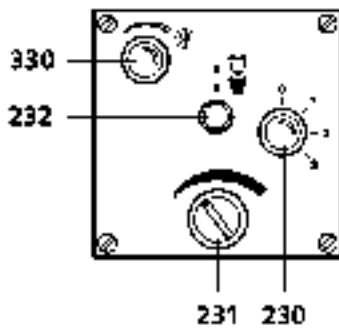
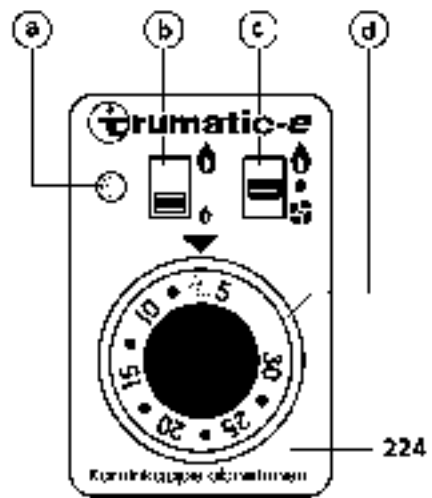
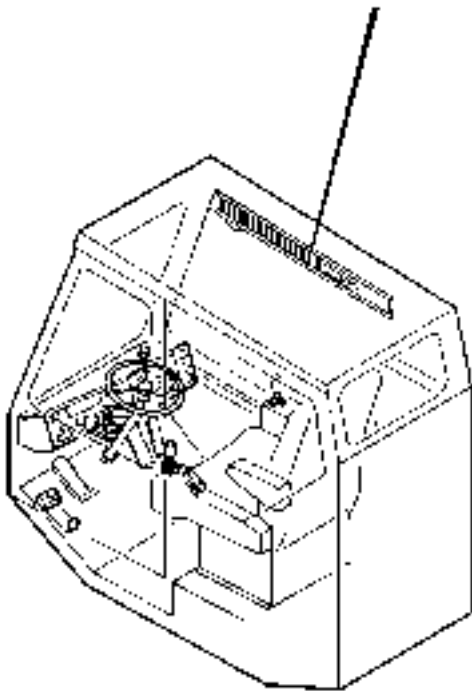
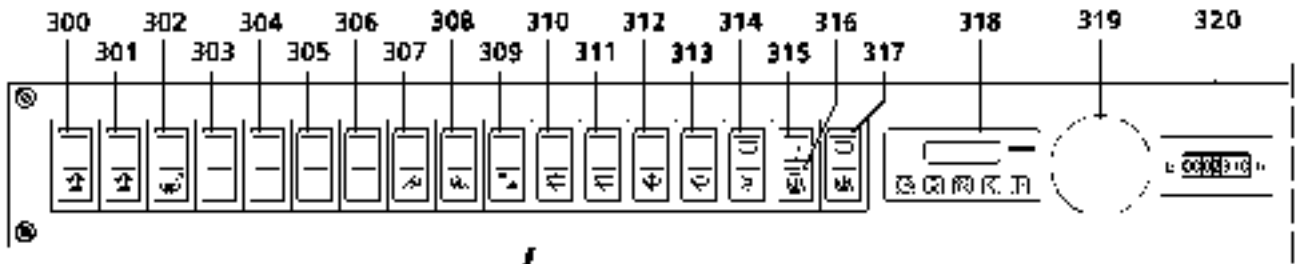

To bleed the system

When draining the crane engine's coolant fluid, the contents of the heating system must also be drained in the crane operator's cab, because the engine coolant system and heater system are part of the same single circuit.

When refilling the system, it must be bled carefully, the quickest way is to bleed the system with the crane engine.

- Via the expansion tank of the crane engine cooling system, add coolant as specified in the lubrication chart.
- Open the bleeder valve on the bleeder line of the auxiliary heater and start the crane engine.
- Move the temperature regulator (231) to "WARM".
- Watch the expansion tank for the crane engine's cooling system, to see if air bubbles rise up.
- If no more air bubbles are visible in the expansion tank, move the temperature regulator (231) to "COLD", which bleeds the circuit for the engine preheat system.
- If even now no more air bubbles rise in the expansion tank, then this circuit is also bled properly.

CAUTION: The bleeder valve must always be closed during crane operation!

The main battery switch may only be turned off after the heater has stopped running!

If any arc welding must be done on the crane, disconnect the negative and positive cable from the vehicle and the crane superstructure batteries to protect the heater controls * and attach both positive cables to the vehicle ground .

Note:

During the summer month, let the auxiliary heater * run once a month, for at least 15 to 20 minutes.

* Optional

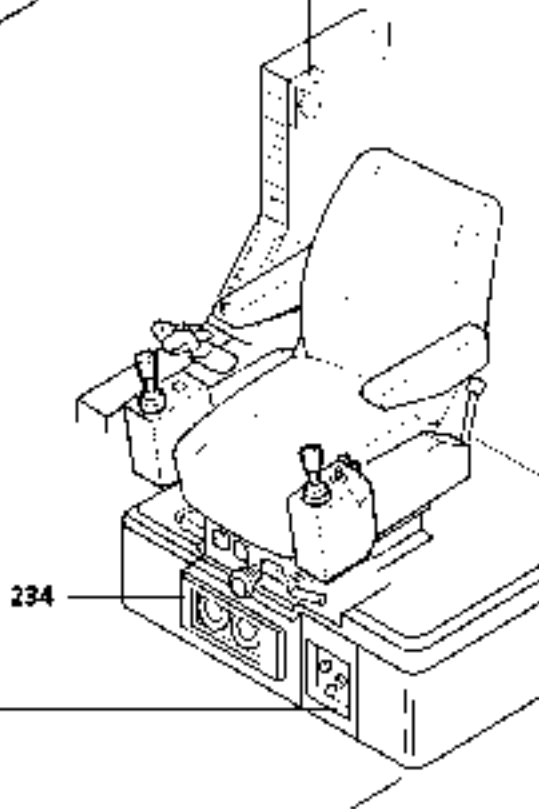
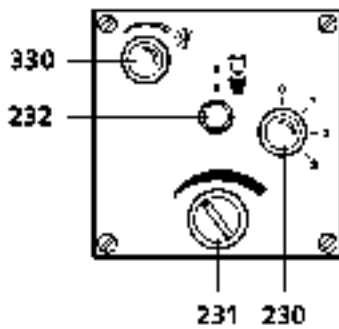
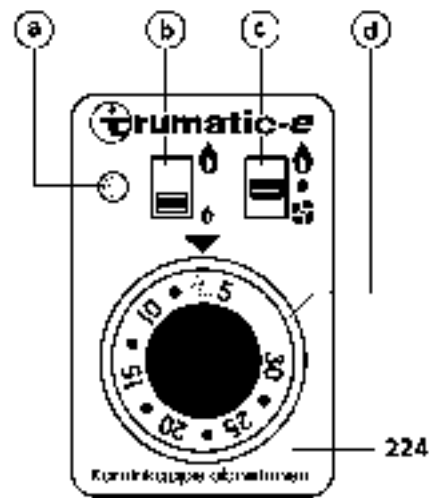
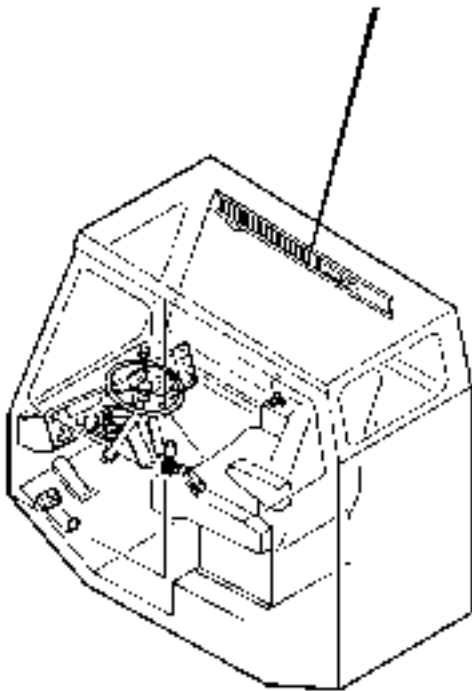
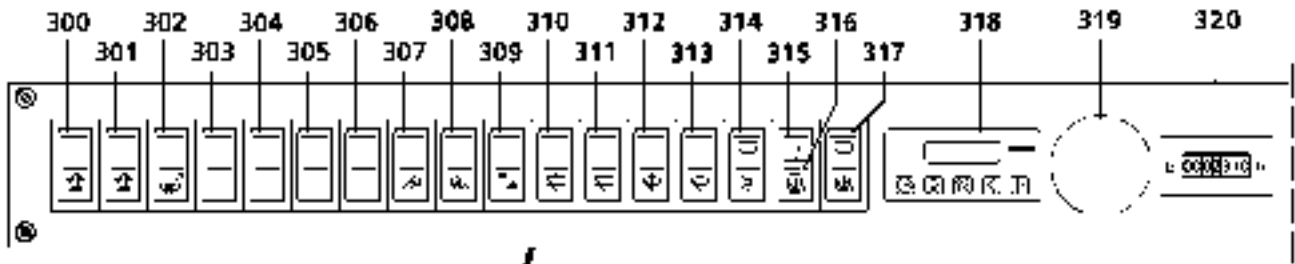

2.3 Air conditioning system *

For a more detailed description, refer to the Operating Manual supplied by the air conditioner manufacturer.

To use the system

- Turn on the main battery switch on and also turn on the ignition of the crane's engine (251).
- Close the regulator for fresh air / circulation (232).
- Turn on the air conditioning system via switch (314), the illuminated indicator light (315) shows that the system is operational.
- Preselect the air flow to the top or bottom by opening or closing the vents (234).
- Turn the blower on via rotary switch (230),
- and adjust the temperature with the regulator (330).

* Optional

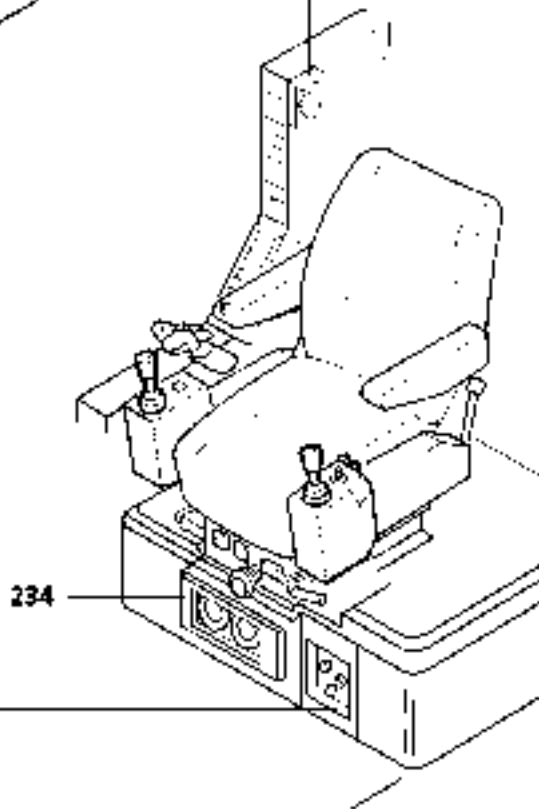
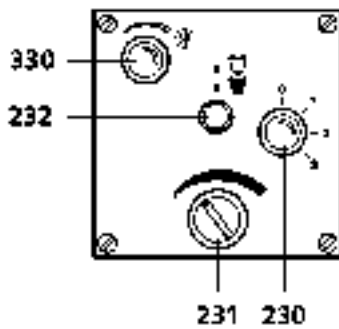
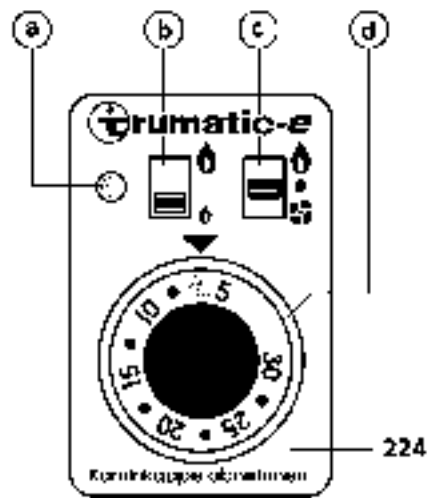
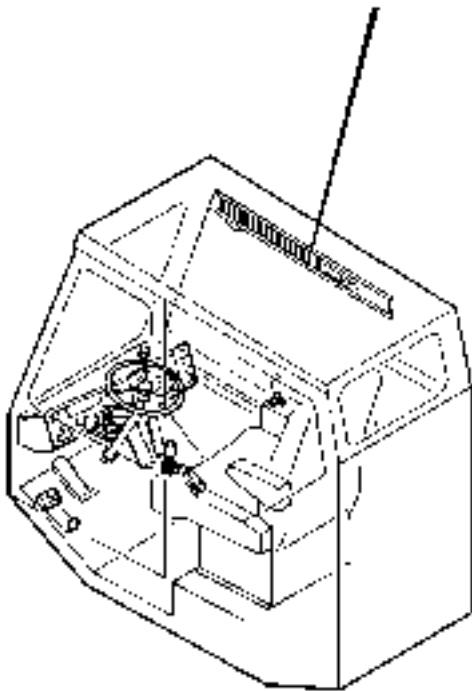
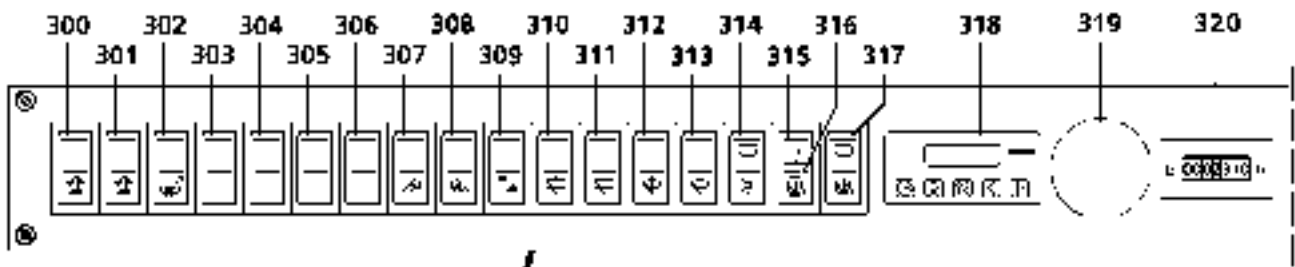

2.4 Auxiliary heater TRUMATIC *

The engine independent, gas operated heater can be used to heat the crane operator's cab. Refer to the more detailed manufacturer's Operation Manual for the TRUMATIC auxiliary heater.

DANGER: The gas heater may NOT be operated during refueling and in closed areas, such as garages, hangars, etc.
If this is not observed, there is great DANGER of EXPLOSION!

Operation

- Turn on the main battery switch (328) and turn on the ignition for the crane engine (282).
- Remove the chimney cover for the auxiliary heater.
- Open the valve on the gas bottle and the quick closure valve in the gas line (rear right, below the crane operator's cab).

- Set the desired room temperature on the rotary knob (d) ,
- Turn the switch (c) to HEAT and turn switch (b) to the desired power.
At low ambient temperatures, run the heater at full power.

- Close the regulator for fresh air / circulated air (253) ,
- Preselect the air flow direction (upward or downward) by closing or opening the air vents (255).

The temperature can now be regulated via the temperature regulating valve (d) and the air flow can be regulated via the blower switch (c).

CAUTION: In Germany, the gas system must be rechecked and tested every 2 years by a DVFG expert.

The operator is responsible to initiate and schedule this service and system check up.

In addition, always make sure to adhere to and observe any rules and regulations applicable to the locality, state or country you are operating in. For your own safety, make sure that the gas installation system and the unit is checked and tested by an expert in regular intervals, but at least every 2 years .

* Optional

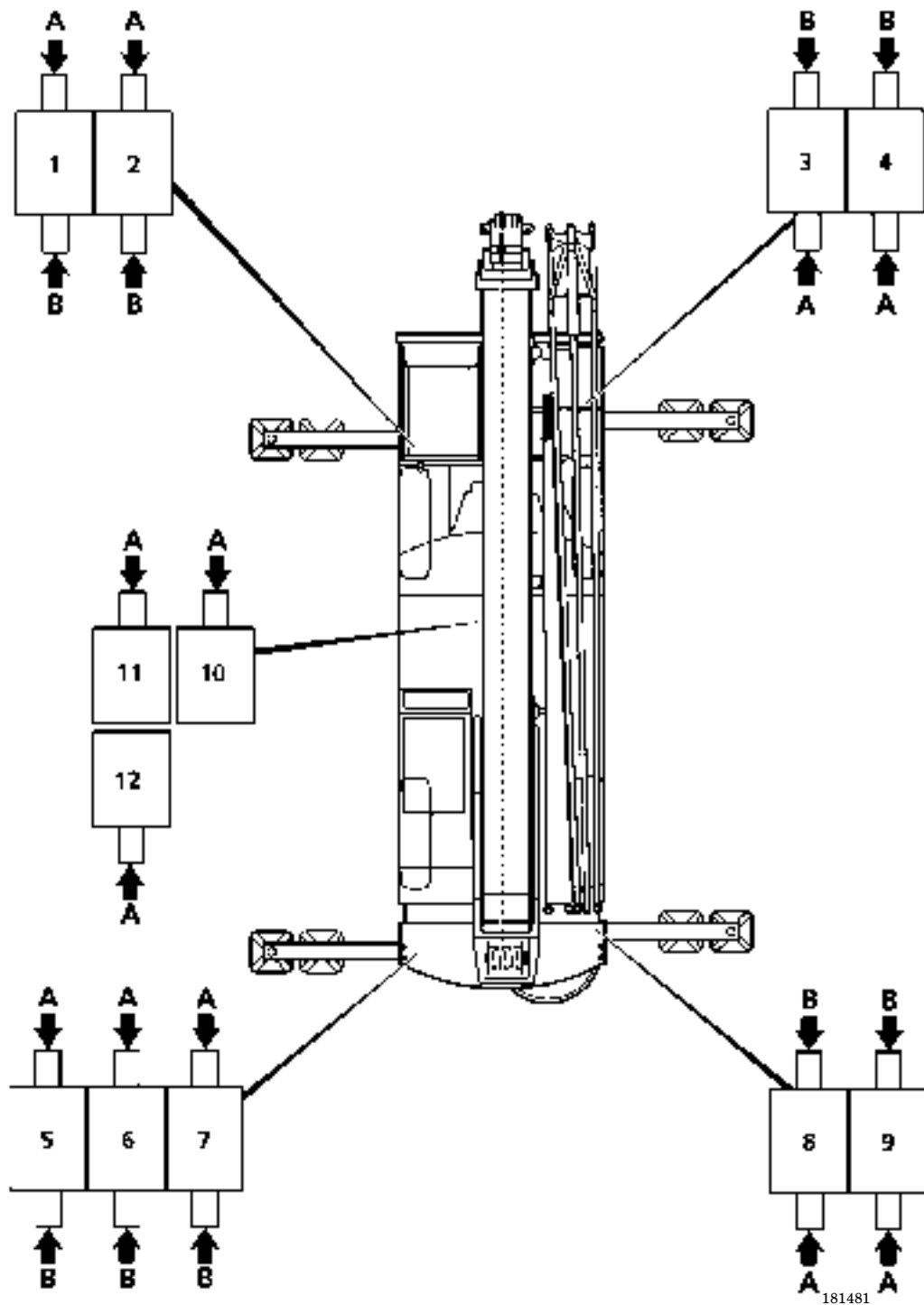
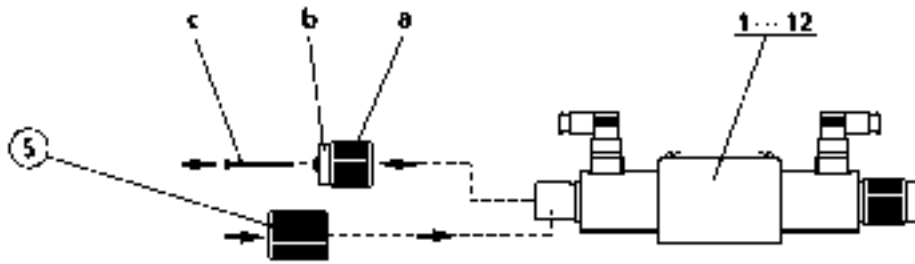

Crane chassis

In case of a failure of the electrical control for the solenoid valves of the hydraulic outriggers and the rear axle steering (solenoid valves 1 to 11), they can be operated manually.

To control the various movements, two solenoid valves each (1 to 4 and 6 to 9) for the outriggers, in addition to another solenoid valve (5) on the left rear for the rear axle steering are located on all four sliding arm boxes.

On the left chassis underside, two solenoid valves (10, 11) are installed on the vehicle frame. These two solenoid valves are installed to change over the function of the crane hydraulic or rear axle steering and outriggers as well as the normal speed or rapid speed.

Note: The emergency activation of the hydraulic outriggers can only be actuated in each case from the opposite side of the vehicle. .

CAUTION: **When extending / retracting the outriggers without visual contact of the corresponding outrigger cylinder or sliding arm, another person must be available to guide the process.**
When extending / retracting the sliding arms, it must be assured that there are no persons or objects within the danger zone.

Prerequisites for emergency activation:

The Diesel engine must be running and the hydraulic system must be functioning properly in the crane chassis.

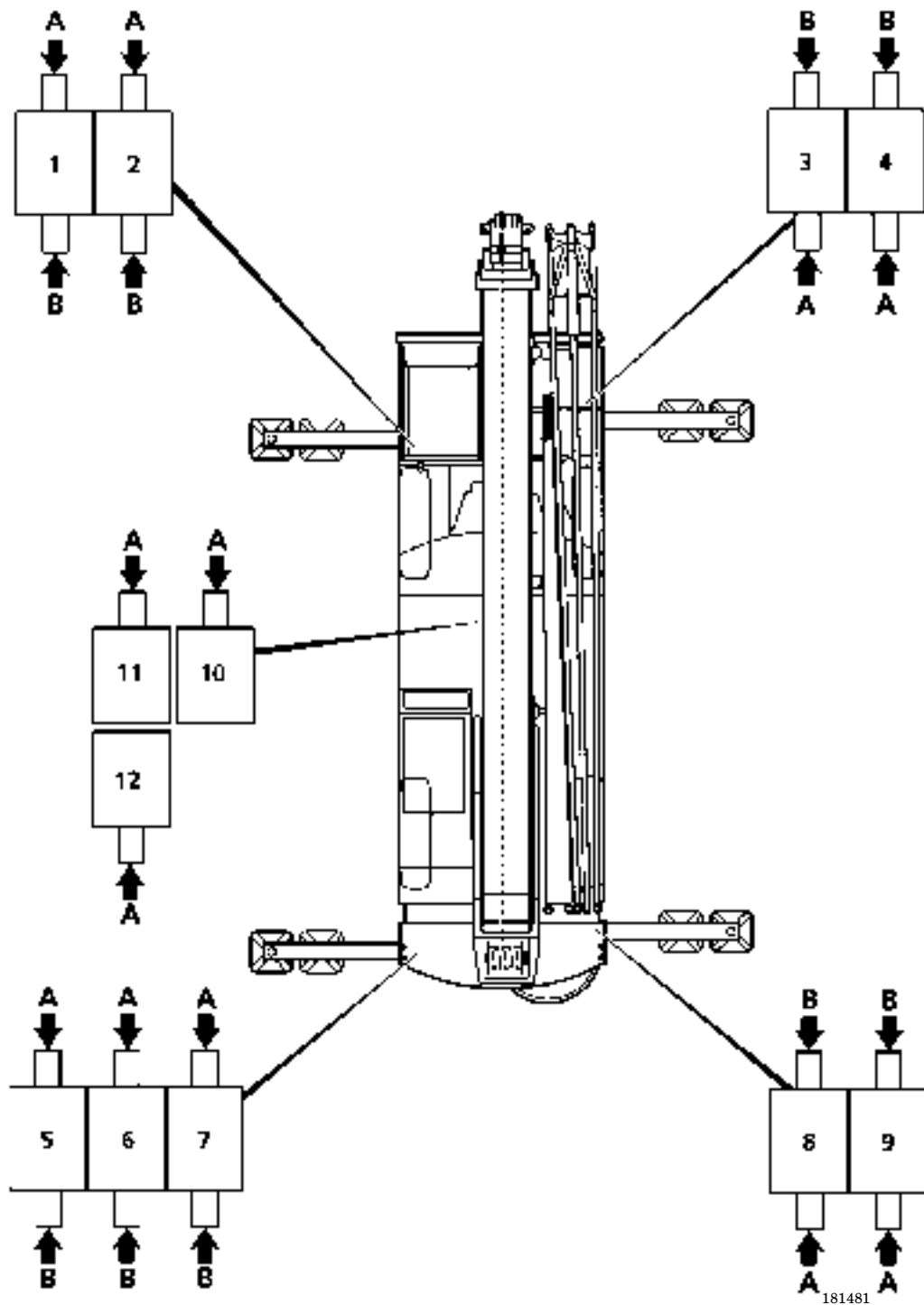
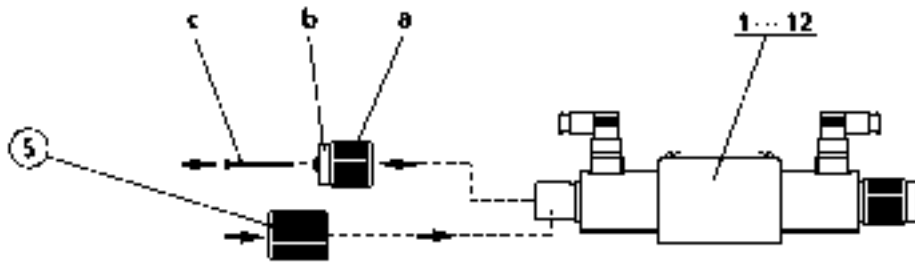

The emergency activation of the hydraulic outriggers and the rear axle steering is to proceed as follows:
For every movement, solenoid valves (10 and 11), as well as the corresponding solenoid valve (1 bis 9) for each movement must be actuated.

- On the front side (A) of the two solenoid valves (10 and 11), unscrew the union nut (a) with dust cap (b) and the actuator pin (c).
- Screw the emergency activation union nut (S) onto the solenoid valves, which shifts the crane hydraulic to the crane chassis.

Note: If solenoid valve (12) is actuated in addition, all movements will proceed in "rapid gear".

- Perform the same procedure on the corresponding solenoid valve (1 to 9). The hydraulic supply is now functioning.
- After completion of the emergency activation, the emergency activation union nut (S) must be removed immediately!

Note: As soon as the pressure on one of the solenoid valves (1 to 11) actuated by the emergency activation union nut (S) stops, the movement stops.









- Reinstall the union nut (a) with dust cap (b) and actuator pins (c) after the emergency activation as before.

Function	Solenoid valve No.	(A) actuated	(B) actuated
Change over from crane hydraulic to hydraulic supply - chassis	10	actuated	–
Hydraulic supply of solenoid valves (1 to 9)	11	actuated	–
"Rapid gear"	11 + 12	actuated	–
Sliding arms - right front	1	retract	extend
Outrigger cylinder - right front	2	retract	extend
Outrigger cylinder - left front	3	retract	extend
Sliding arm - left front	4	retract	extend
Rear axle steering	5	left - in	right - in
Sliding arm right rear	6	retract	extend
Outrigger cylinder right rear	7	retract	extend
Outrigger cylinder left rear	8	retract	extend
Sliding arm left rear	9	retract	extend

The emergency activation to steer the rear axle must be done correspondingly.

This emergency activation is used to return the rear wheels back the straight ahead position, in case there is a defect in the electrical control when the rear axle steering stopped with the wheels turning inward, which prevented the return to straight ahead position. It is easier to return the wheels to straight ahead position while rolling slowly.

See also chapter 3.04, "TRAVEL ON PUBLIC HIGHWAYS".

Stellung der Hahnschlüssel bei Kranbetrieb		
Hahnchlüsselstellung Notbetrieb		
 2	 4	 3
drehen links	drehen rechts	1 Tele ein
 6	 7	 8
1. Hubwerk ab	2. Hubwerk ab	5 abwippen
Bei Betrieb mit Notaggregat beachten:		
1. Notaggregat starten		
2. Hahnschlüssel Nr. 10 in Stellung  bringen		
3. Bewegung nach obiger Tabelle ausführen		

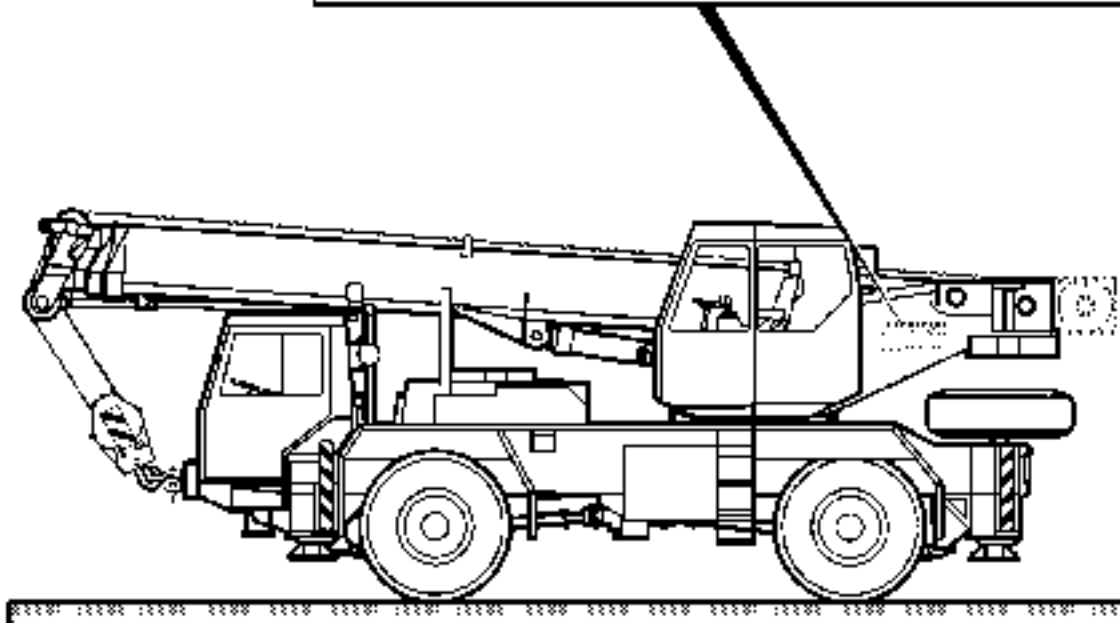
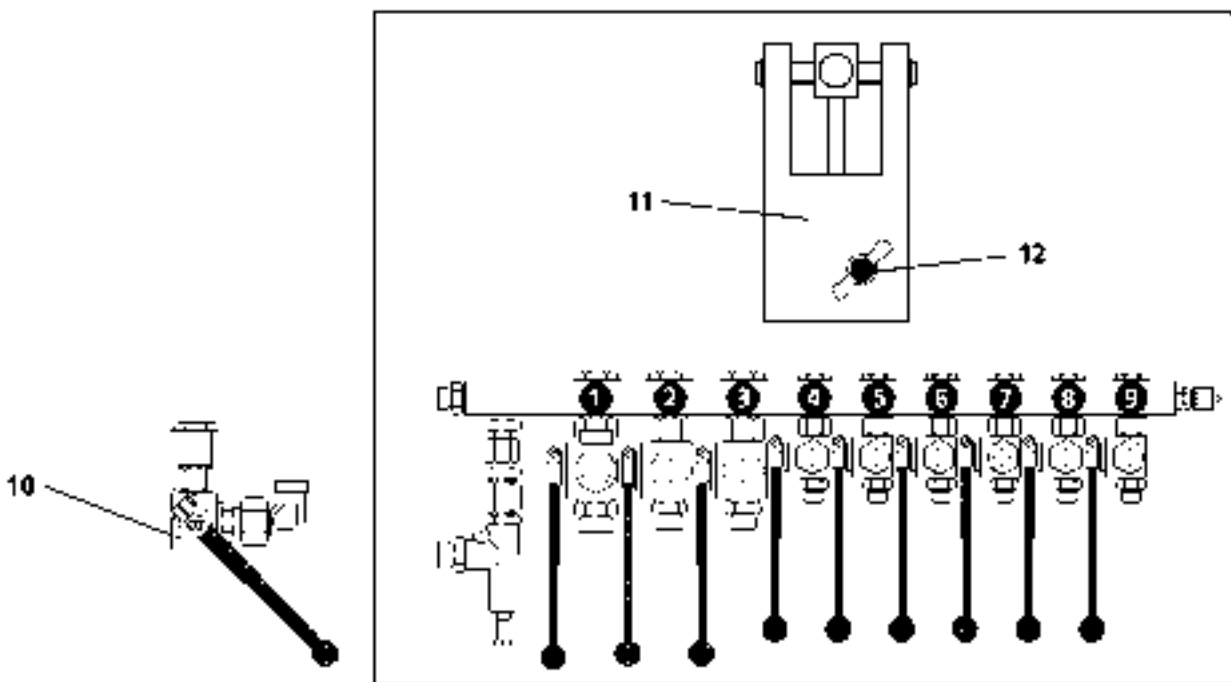

Crane chassis:

Should the electrical control of pilot valves fail, the hydraulic supports and rear axle steering can be manually activated.

Note: Emergency operations with the working platform must be carried out in conjunction with persons working on the platform so that the platform remains aligned and leveled.

Emergency operation with hand pump

On the left on the slewing platform are 6 or 10 ball valves (1 to 6 or 1 to 10), depending on the model, and a hand pump (11) with a bypass valve (12).

For normal crane operations, the hand wrenches (1 to 6 or 1 to 10) of the ball valves must be pointing down.

For emergency manual activation, the individual hand wrenches assigned to each of the crane movements must be switched to the upward position ("Emergency mode" position).

Note: In emergency mode, only one crane movement can be carried out at a time.

- For the crane movement "Slewing gear to the left", move the hand wrenches of ball valves 2 and 4 to the "emergency mode" position; all other hand wrenches remain in the "crane operation" position.
- For the crane movement "Slewing gear to the right", move the hand wrenches of ball valves 3 and 4 to the "emergency mode" position; all other hand wrenches remain in the "crane operation" position.
- For the crane movement "luffing down", move the hand wrench of ball valve 5 to the "emergency mode" position; all other hand wrenches remain in the "crane operation" position.

CAUTION: During emergency activation, the hoist limit switch is incapable of shutting down the movement.













- For the crane movement "Retract telescope", move the hand wrench of ball valves 1 to the "emergency mode" position; all other hand wrenches remain in the "crane operation" position.
- For the crane movement "Lower 1st hoisting gear**", move the hand wrenches of ball valves 6 and 7 to the "emergency mode" position; all other hand wrenches remain in the "crane operation" position.
- For the crane movement "Lower 2nd hoisting gear**", move the hand wrenches of ball valves 8 and 9 to the "emergency mode" position; all other hand wrenches remain in the "crane operation" position.

Activation

- Close the bypass valve (12) on the hand pump (11).
- Insert the lever extension (12) on the hand pump (10) and activate the pump by hand. If the crane movement is carried out too quickly, the speed of the movement can be slowed, or completely stopped, by partially or completely closing the bypass valve (12).
- After concluding emergency manual activation, bring the hand wrenches (1 - 7) back to the "crane operation" position (down).
- Reopen bypass valve (12) on the hand pump.

Note: When using emergency activation, all specifications given in the load capacity table must be adhered to.
Luffing the telescopic boom may only be carried out within the ranges specified in the load capacity table.

*) **) special equipment

Stellung from Hahnschlüssel bei Kranbetrieb			
Hahnchlüsselstellung Notbetrieb			
 2	 4	 3	 4
drehen links		drehen rechts	
			 1 Tele ein
 6	 7	 8	 9
1. Hubwerk ab		2. Hubwerk ab	
			 5 abwippen
Bei Betrieb mit Notaggregat beachten:			
1. Notaggregat starten			
2. Hahnschlüssel Nr. 10 in Stellung  bringen			
3. Bewegung nach obiger Tabelle ausführen			

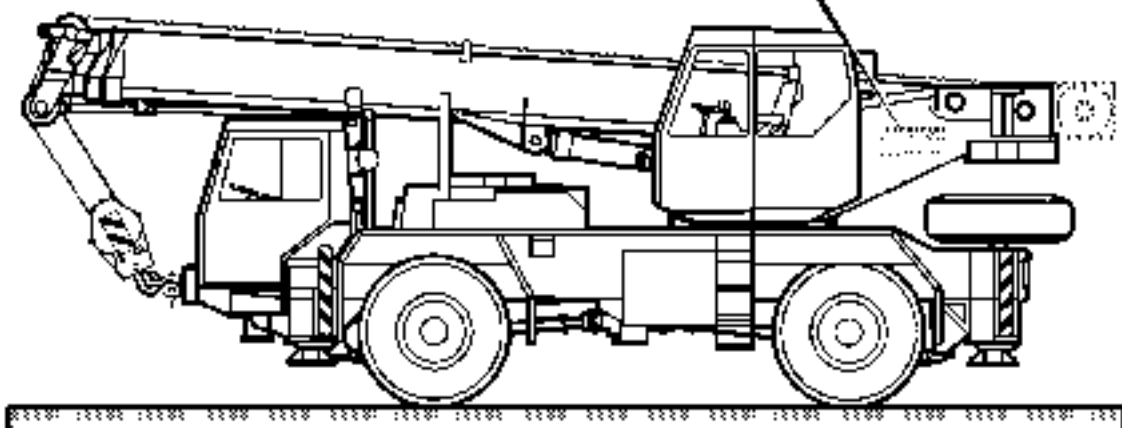
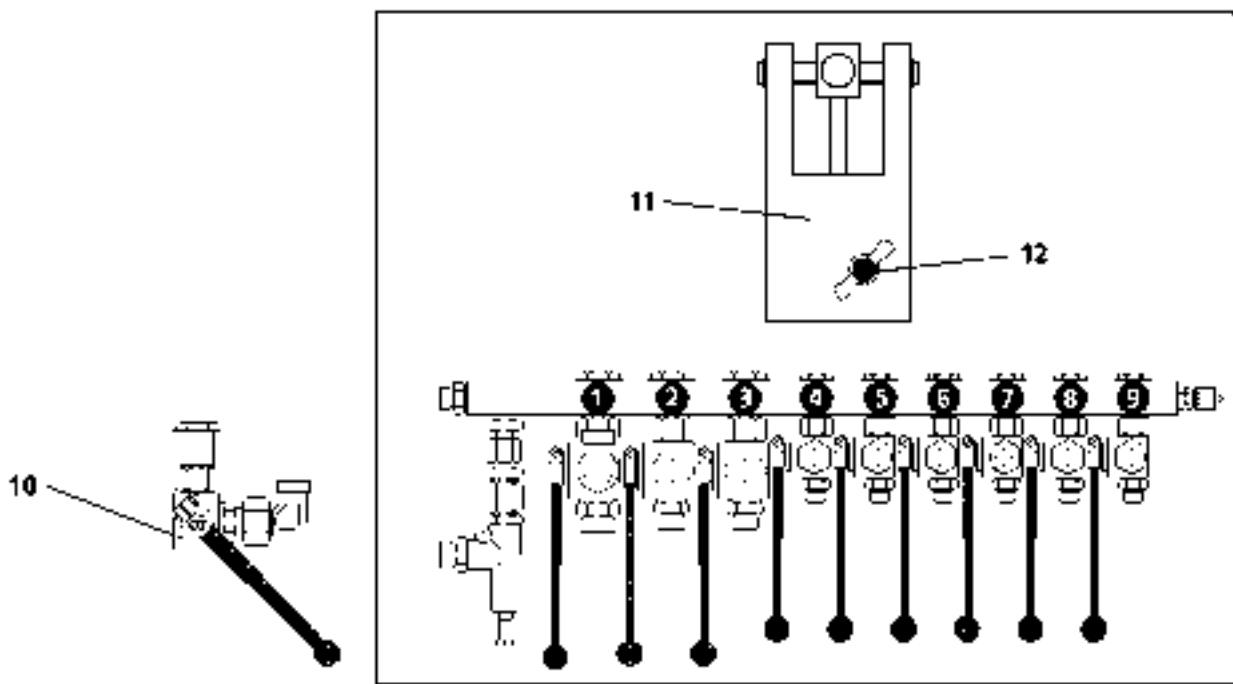

Emergency operation with emergency aggregate *

- Start the emergency aggregate.
- Move hand wrench (10) "up".
- Preselect the desired crane movement by setting the appropriate ball valve.

Note: The load should first be lowered via the hoisting gear; the remaining crane movements are then carried out to bring the crane to the transport position.
Should the crane movements prove to be too fast, they can be slowed or halted by partially or completely opening the ball valve (10).

- After concluding the emergency activation, the hand wrenches (1 to 10) must again be brought to the "crane operation" (up).
- Switch off emergency aggregate.

* special equipment

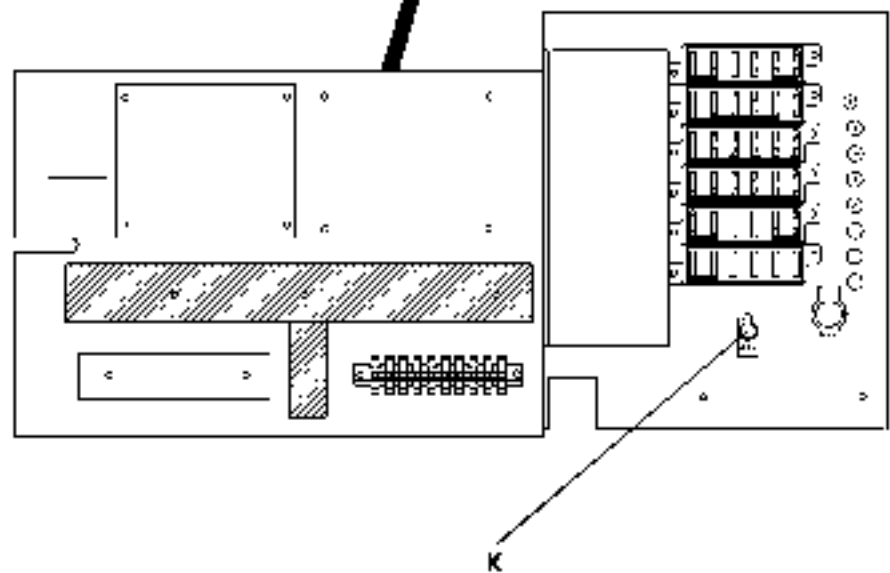
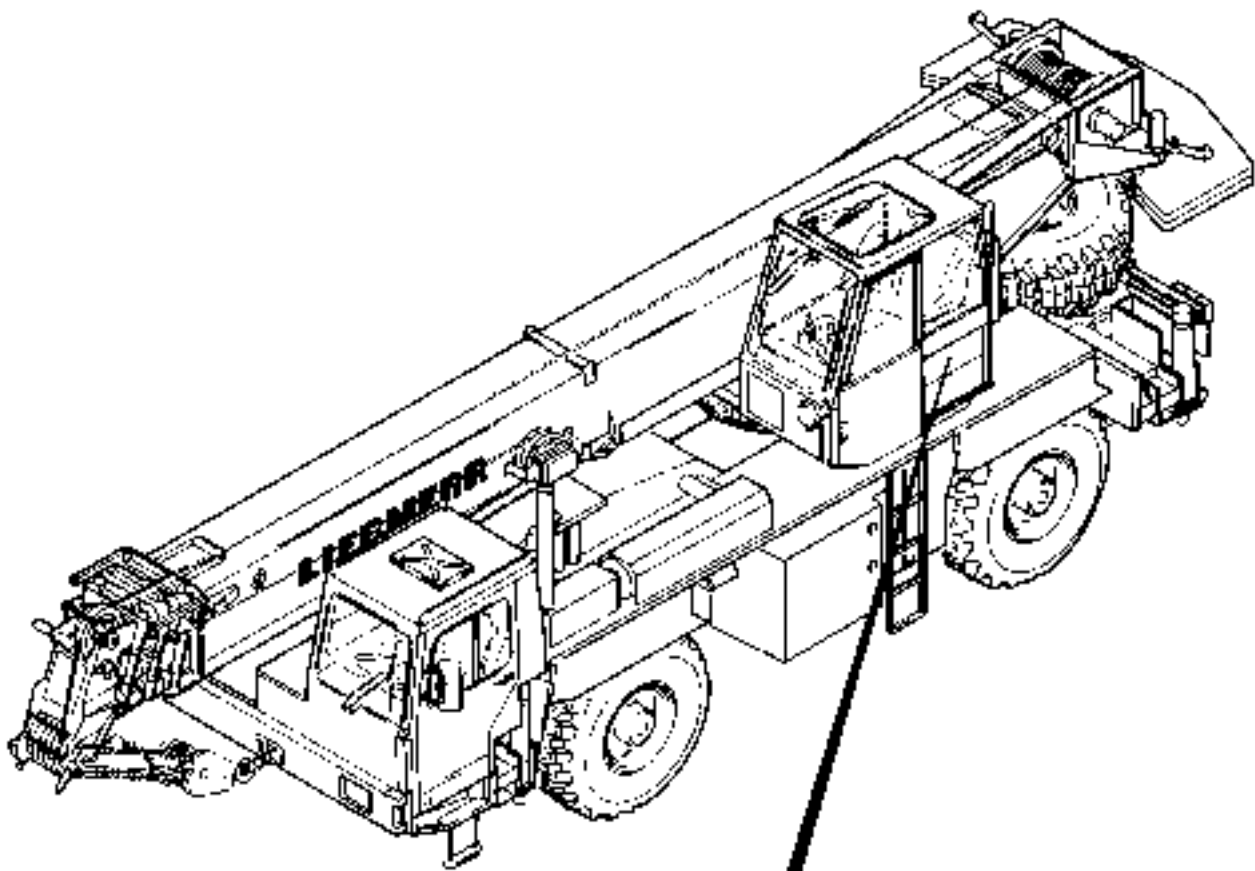

Button with self-retention (K) for bypassing the electrical crane control.

With the diesel engine at a standstill or should the generator fail, the electrical crane control can be switched on by activating the bypass button (K).

- Switch button (K) to position "ON" (down).

Note: When carrying out this procedure, battery voltage must **not** exceed 20 volts.
The bypass button (K) is integrated in the switching cabinet for electrical crane control laterally mounted in the crane cab.

CAUTION: During crane operations the bypass switch must be switched to the "OFF" position.

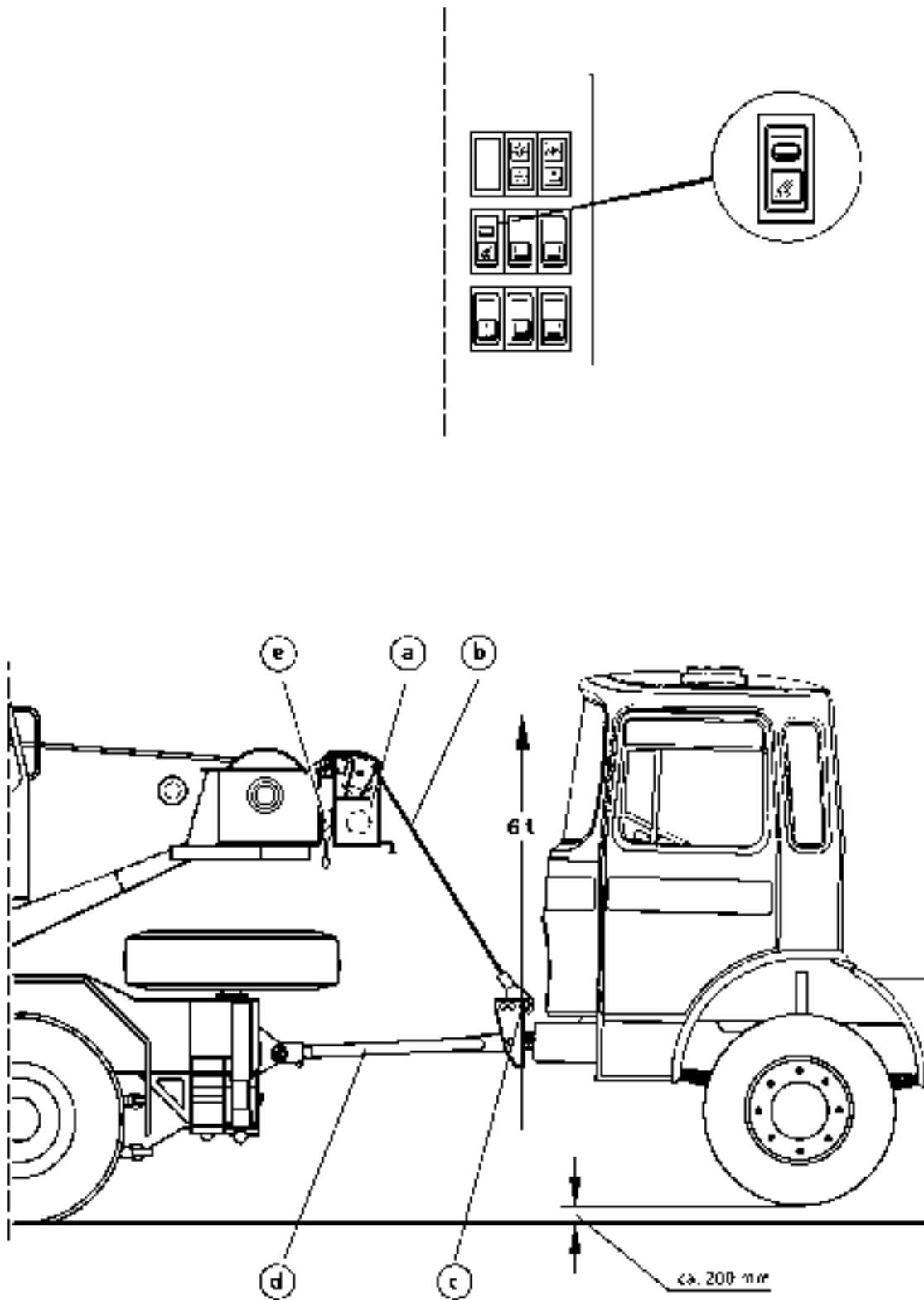

Towing device *

The towing device consists of the triangular fork (d,) which is swung down for towing stranded vehicles, and of the hoisting attachment mounted on the slewing platform and the additional ballast (a).

Equipment mode for towing

- The crane superstructure is locked with the crane chassis with lynch pins.
- The supports are retracted and secured.
- The hoisting attachment is mounted on the additional ballast and pinned with bar.
- 2100 kg ballast is mounted on the ballast frame.
- 1200 kg ballast is set on the crane chassis.
- The hook block (up to 140 kg) is suspended on the front tow coupling.
- The spare tire is attached at the rear to the crane chassis.
- The folding fly jib is folded.

Towing procedure

The uninterrupted towing route may not exceed 50 km; after 50 km, a pause of at least one hours must be made in order to allow the tires to cool.

Air pressure: with tires 14.00 - 25 = 10 bar
with tires 17.50 - 25 = 7 bar

- Start the drive and crane engine and allow to run,
- In the driver's cab, switch over to position "superstructureposition " with the change-over switch,
- Lock axle suspension with switch (62),
- Attach the hoisting cable (b) of the towing device to the towing fork (c) with pins and secure with spring keepers.
- Remove transport locking of the towing fork and swing the fork down.
The towing fork can be raised or lowered using the manual lever (e).
- Attach the vehicle to be towed to the lowered triangular fork (d).
- With the aid of the towing device, raise the vehicle to be towed approx. 200 mm.
(front axle clear of the ground). The maximum tension on the cable in this case is 8 t.
- In the driver's cab, switch over to driving mode (vehicle symbol) with the change-over lever.

CAUTION: When towing, axle suspension must be blocked.

Permissible towing speeds

Attached load [t]	Driving speed [t]		Axle load [t]	
	Tires 14.00 - 25	Tires 17.50 - 25	Front axle	Rear axle
0	75	75	12.00	12.00
1	40	40	11.20	13.80
2	20	20	10.40	15.60
3	15	15	9.50	17.50
4	10	10	8.70	19.30
5	5	5	7.90	21.10
6	5	5	7.10	22.10

* special equipment

Chapter 7

Service and Maintenance

Liebherr After Sales Service - what it means for you

Liebherr truck-mounted, mobile and crawler cranes are products incorporating mature engineering which is able to cope day in, day out with the roughest operating conditions to which a crane may be subjected.

The high standards of engineering embodied in these cranes are reflected in their operation reliability, their insusceptibility to faults and in their ease of servicing and maintenance.

Liebherr is constantly further developing their drive and control elements. The combination of tried and tested components and modern production methods produces cranes which are reliable operating partners with a range of convenient operating features.

We build many hundreds of cranes each year for the international market and provide the backup services for them worldwide, too. For "After Sales Service" ranks high at Liebherr to ensure that your crane is always available and operational.

Service at Liebherr begins from the moment the crane is handed over to you, the customer. We will provide your crane operators with the specialist training tailored to their particular needs.

Also we will train your maintenance personnel in all questions relating to crane servicing and repairs because we know that you are able not only to deal with all their minor repairs, but often have the specialists who can quickly and reliably perform major crane repairs.

A further benefit of our After Sales Service are our special Service Advisors who are only a telephone call away whenever a problem arises. This immediate contact saves you time and money and you should always take advantage of it whenever your crane is "down".

Our Field Technicians are also specialists with many year's experience who operate from strategically located bases. They bring with them their specialist knowledge and a range of special tools for the job. They are at your disposal as the last link in the range of Liebherr After Sales Services, although in most cases, your technical problems can be solved by contacting our Service Advisors.

Cleaning and upkeep of crane

Wash crane with water

Note: If a steam jet is used for cleaning, a distance of at least 80 cm (2' 7") must be kept to the paint work and foil label.

After cleaning, in particular with the steam jet, lubricate crane, e.g. drive shafts, slewing connections.

Steering wheel, centre console, control panel covering, floor covering and dirty upholstery in driver's cab and crane cabin should only be cleaned with warm water mixed with a dish washing agent.

Do not use scouring agents!

The scope of maintenance works are described in the following chapters.

7.02 MAINTENANCE INTERVALS CRANE CHASSIS

7.03 MAINTENANCE INTERVALS CRANE SUPERSTRUCTURE

Maintenance work must carried out according the crane.

The following chapters describe maintenance work in more detail.

7.04 MAINTENANCE INSTRUCTIONS CRANE CHASSIS

7.05 MAINTENANCE INSTRUCTIONS CRANE SUPERSTRUCTURE

For individual assemblies note manufacturers instructions.

Maintenance work on the crane chassis is carried out according to the number of operating hours or kilometres covered.

Maintenance work on the crane superstructure is carried out according to the number of operating hours only.

	1st main- tenance after	regular maintenance every			minimum main- tenance annually	inspections	
		200 hrs. 5000 km	400 hrs. 10000 km	800 hrs. 20000 km		daily	weekly
<input type="checkbox"/> Diesel engine							
- Check oil level For all further maintenance work, observe manufacturer's instructions						×	
- Check coolant level in equalizing reservoir						×	
- Change coolant liquid					every 2 years		
<input type="checkbox"/> Air filter							
- Observe monitoring device						×	
- Clean or exchange (observe engine manufacturer's instructions)							
<input type="checkbox"/> Steering							
- Check the steering hydraulic oil level							×
- Test steering rod and tie rod tightness and split pin keepers		×					
- Check hydraulic system for proper seals						×	
- Test tie rod setting, test if necessary		×	*				
- Oil change				×			
- Replace oil filter	100 hrs.		×				
- Test hydraulic steering stop, test if necessary				×			
- Check hydraulic pressure, set if necessary				×			

* If used heavily off-road, at least 1 × per year.

	1st main- tenance after	regular maintenance every			minimum main- tenance annually	inspections	
		200 hrs. 5000 km	400 hrs. 10000 km	800 hrs. 20000 km		daily	weekly
<input type="checkbox"/> Automatic transmission							
- Check oil level						×	
- Check oil pressure						×	
- Check operating temperature						×	
- check for proper seals							×
- Check / tighten fastening screws		×					
- Oil change	100 hrs.			×	×		
- Replace oil filter	100 hrs.			×	×		
<input type="checkbox"/> Power shift gearbox							
- Check oil level						×	
- check for proper seals							×
- Oil change	100 hrs.		×		×		
- Replace oil filter	100 hrs.		×		×		
<input type="checkbox"/> Displacement gear							
- check for proper seals							×
- check fastenings		×					
- oil change				×	×		
<input type="checkbox"/> Distribution gearbox							
- Oil change	1000 km	×			×		
- Check oil level							×
- Check for proper seals						×	
- Check/tighten fastening screws		×					
- Check road/off-road gear switchover function							×
- Check all-wheel drive switch- on function							×
- Check tachometer connection		×					
- Clean ventilation nipple				×	×		

	1st main-tenance after	regular maintenance every			minimum main-tenance annually	inspections	
		200 hrs. 5000 km	400 hrs. 10000 km	800 hrs. 20000 km		daily	weekly
<input type="checkbox"/> Drive shafts (cardan shafts) and bearing bracket							
- Grease				25000 km	every 2 years *		
- Check flange screws, tighten if necessary	100 km	2500 km					
<input type="checkbox"/> Driven axles							
- Test for proper seals						×	
- Oil level check at axle housing, differential housing and wheel hubs		×					
- Grease steering knuckle bearings				25000 km	every 2 years **		
- Check fastening		×					
- Oil change	1000 km			×	every 2 years		
- Clean ventilation on axle housing				×	×		
<input type="checkbox"/> Non-driven axles							
- Grease steering knuckle bearings				25000 km	every 2 years **		
- Check fastening		×					
- Change wheel hub grease filling				×	×		
- Set wheel bearings				×	×		

* Maximum grease pressure: 15 bar. If used heavily off-road, at least 1× per year.

** If used heavily off-road, at least 1× per year.

	1st main-tenance after	regular maintenance every			minimum main-tenance annually	inspections	
		200 hrs. 5000 km	400 hrs. 10000 km	800 hrs. 20000 km		daily	weekly
<input type="checkbox"/> Tires							
- Check lug nut tightness, tighten if nec.	100 km	×					
- Check tire pressure							×
<input type="checkbox"/> Brake system							
- Check brake lining wear		×					
- Adjust brakes, if necessary, replace linings		×					
- Grease		×					
- Oil fork head connections		×					
- Check service brake and hand brake functioning						×	

	1st main-tenance after	regular maintenance every			minimum main-tenance annually	inspections	
		200 hrs. 5000 km	400 hrs. 10000 km	800 hrs. 20000 km		daily	weekly
<input type="checkbox"/> Compressed air system							
- Test for proper seals							×
- Check brake system operating pressure						×	
- Check shutdown pressure						×	
- Check pressurized air reservoir automatic water bleeder valve functioning		×					
- Replace air dryer granulate cartridges					×		
- Clean air dryer pre-filter					×		
<input type="checkbox"/> Axle suspension							
- Check hydraulic tank oil pressure							×
- Check hydraulic system seals							×
- Blocking cylinder function test		×					
- Replace oil filter	100 h		×				
- Check hydraulic pressure, set if necessary				×			
- Check pressure reservoir priming pressure (nitrogen)				×	×		
- Oil change				×	×		

* refer to chapter 7.04, MAINTENANCE INSTRUCTIONS CRANE CHASSIS

	1st main- tenance after	regular maintenance every			minimum main- tenance annually	inspections	
		200 hrs. 5000 km	400 hrs. 10000 km	800 hrs. 20000 km		daily	weekly
<input type="checkbox"/> Hydraulic supports							
- Check hydraulic system seals							×
- Check hydraulic tank oil pressure							×
- Check sliding arm movement / oil		×					
- Grease fleyer chains		×					
- Oil sliding arm keeper pins							×
- Oil operating level fork heads							×
- Check level, adjust if nec.							×
- Oil change (oil sample)				×	×		
- Replace hydraulic filter	100 hrs.		×				
- Replace bleeder filter on hydraulic tank	100 hrs.		×				
- Check hydraulic system operating pressure				×			
<input type="checkbox"/> Hydraulic accessories, e.g. ventilator, ballasting cylinders							
- Check hydraulic operating pressure, set if necessary			×				
<input type="checkbox"/> Driver's cab							
- Check armature function						×	
- Check indicator light function						×	
- Check motor brake activation						×	
- Check retarder activation						×	

For crawler cranes only	regular maintenance every			minimum maintenance annually
	10 hrs.	100 hrs.	800 hrs.	
<input type="checkbox"/> Running gear				
- Oil change			×	×
- Check seals	×			
- Grease tumbler bearing	×			
<input type="checkbox"/> Track carrier				
- Check seals on track rollers (with oil lubrication)	×			
- Grease track rollers (with oil lubrication)	×			
- Grease support rollers	×			
- Grease guide rails on sliding piece				×
<input type="checkbox"/> Track shoes				
- Check shoe tension, tighten if necessary	×			
- Inspect for fastening and damage	×			

	1st main- tenance after	regular maintenance every				minimum main- tenance annually	inspections	
		100 hrs.	200 hrs.	400 hrs.	1200 hrs.		daily	weekly
<input type="checkbox"/> Diesel engine								
- check oil level for further inspections please refer to manufacturers maintenance instructions							×	
- check cooling water level in the extension tank							×	
- change cooling water						every 2 years		
<input type="checkbox"/> Air filter								
- check dust indicator							×	
- clean resp. change according to manufacturers maintenance instructions								
<input type="checkbox"/> Slewing ring								
- inspect and check bolts for tightness	200 hrs.			×		×		
<input type="checkbox"/> Telescopic boom pivots								
- lubricate		×						
<input type="checkbox"/> Rope winches								
- inspect for leaks							×	
- check oil level								×
- oil change					3000 hrs.	every 4 years		
<input type="checkbox"/> Propeller shafts								
- check flange bolts		×						
- lubricate		×						

	1st main-tenance after	regular maintenance every				minimum main-tenance annually	inspections	
		100 hrs.	200 hrs.	400 hrs.	1200 hrs.		daily	weekly
<input type="checkbox"/> Overtopping guard struts								
- lubricate pivots			×					
<input type="checkbox"/> Fall back cylinders								
- inspect for leaks	×	*						
- check preload pressure (nitrogen gas)				×		×		
- check oil quantity				×		×		
<input type="checkbox"/> A bracket mounting								
- lubricate			×					
<input type="checkbox"/> Counterweight								
- check fastening bolts for tightness	1000 km			or 10000 km				
<input type="checkbox"/> Ballasting system								
- lubricate pivots			×					
<input type="checkbox"/> Rope drum contact rollers								
- grease guides			×					
<input type="checkbox"/> Rope pulleys and ropes								
- inspect, grease if necessary			×			×		
<input type="checkbox"/> Hook blocks								
- lubricate			×					

* visual check before starting up the crane

	1st main- tenance after	regular maintenance every				minimum main- tenance annually	inspections	
		100 hrs.	200 hrs.	400 hrs.	1200 hrs.		daily	weekly
<input type="checkbox"/> Crane cab								
- check operation of instruments							×	
- check operation of tell-tale warning lights							×	
- check liquid level in the reservoir of the engine speed control							×	
<input type="checkbox"/> Extending crane cab								
- check operation			×					
- lubricate pivots			×					
<input type="checkbox"/> Load moment limiter								
- check operation							×	
<input type="checkbox"/> Slewing gear transmission								
- inspect for leaks							×	
- check oil level								×
- change oil					4000 hrs.	every 4 years		
<input type="checkbox"/> Locking of the slewing brake								
- check operation		×						
- lubricate			×					

	1st main-tenance after	regular maintenance every				minimum main-tenance annually	inspections	
		100 hrs.	200 hrs.	400 hrs.	1200 hrs.		daily	weekly
<input type="checkbox"/> Pump distributor gearbox								
- check oil level							×	
- oil change	400 hrs.				×	×		
<input type="checkbox"/> Hydraulic system								
- check oil level							×	
- check for leaks								×
- replace control and feed circuit pressure filter element	200 hrs.			×				
- replace returnline filter element	200 hrs.			×				
- replace bleeder filter on hydraulic tank	200 hrs.			×				
- check hydraulic oil (oil sample test)	400 hrs.				×	×		
<input type="checkbox"/> Hydraulic cylinders								
- inspect for leaks								×
<input type="checkbox"/> Hydraulic pressure reservoirs (nitrogen gas)								
- check preload pressure				×	*	×	*	
<input type="checkbox"/> Rope mechanism in the telescopic boom								
- check setting, adjust if necessary	200 hrs.			×				
<input type="checkbox"/> Pneumatic boom locking								
- clear the air filter for compressed air		×				×		
- check boom locking holes				×		×		
- lubricate boom locking bolts					×	×		

* refer to chapter 7.05, MAINTENANCE INSTRUCTIONS CRANE SUPERSTRUCTURE

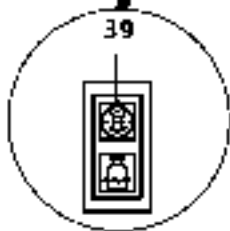
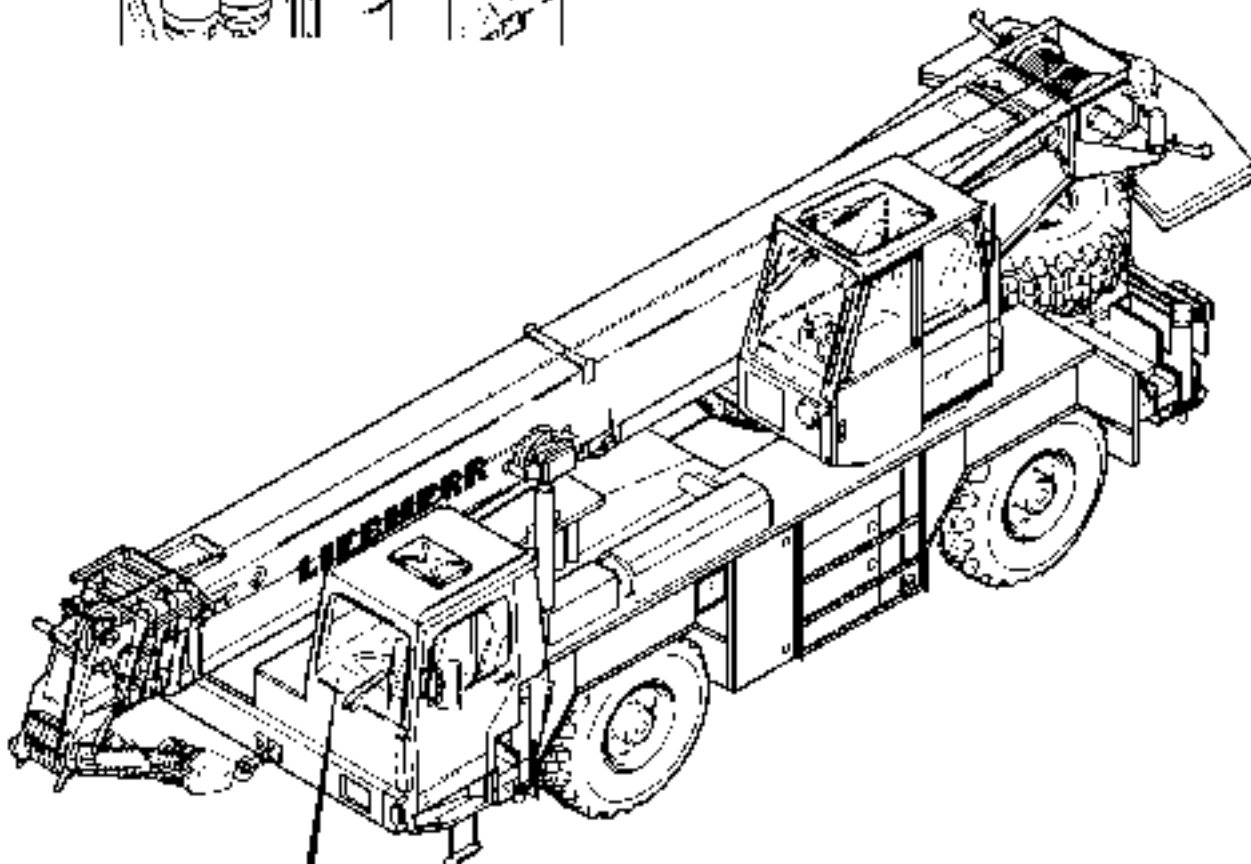
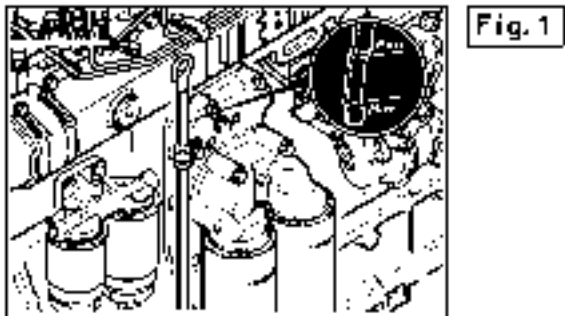
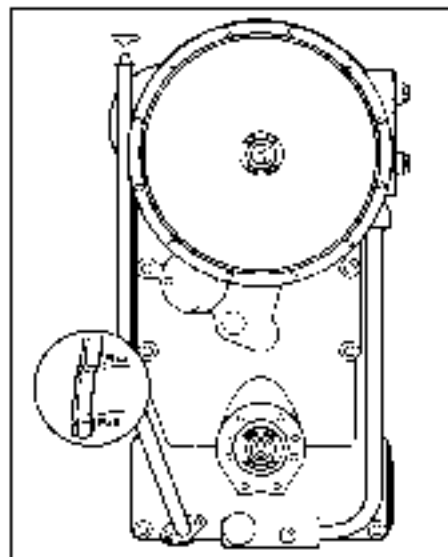

Fig. 2



Oil level and filter check

Check the oil level with the crane standing horizontally.
The engine is off; oil has collected in the oil pan.

Check oil level in the drive engine (Fig. 1)

The oil must be between the minimum and maximum markings on the dipstick.

CAUTION: If the oil level falls below the MIN. marking on the dipstick, it must be refilled immediately with engine oil specified in the LUBRICATION TABLE until the oil level is again between the MIN. and MAX. markings. Oils levels below these markings can cause engine damage.

Reinsert the dipstick.

Drive engine air filter

The air filters are monitored electronically. If a partial vacuum occurs in the air intake line because the air filter elements are contaminated, warning lamp (39) on the instrument panel comes on.
In this case, clean or renew the filter elements according to the engine manufacturer's instructions.

Note: Maintenance and service work on engine and air filters must be carried out in accordance with the separate engine operating instructions.

Note the following when carrying out maintenance or repair work around the engine.

Never step on fuel lines.

DANGER: The engine area must be absolutely free of diesel fuel, as otherwise there is the risk of FIRE! Extreme cleanliness must always be ensured, especially when changing filters and bleeding air. All fuel spills must be dried up. When changing filters, before unfastening the filter it is advisable to spread out absorbent wool to absorb the diesel fuel.

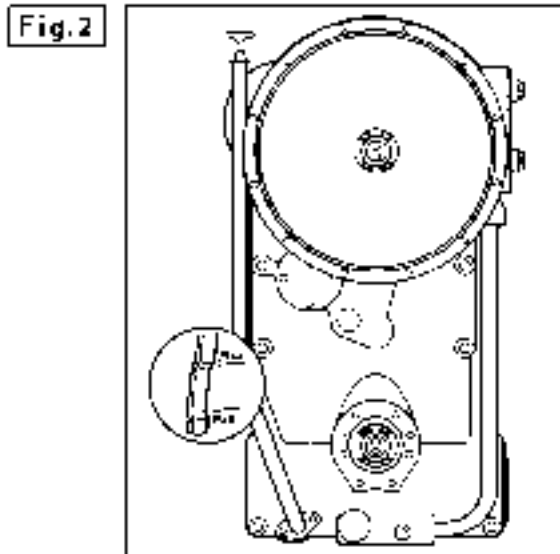
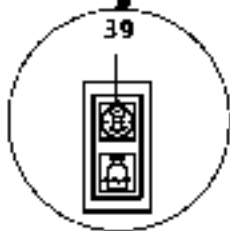
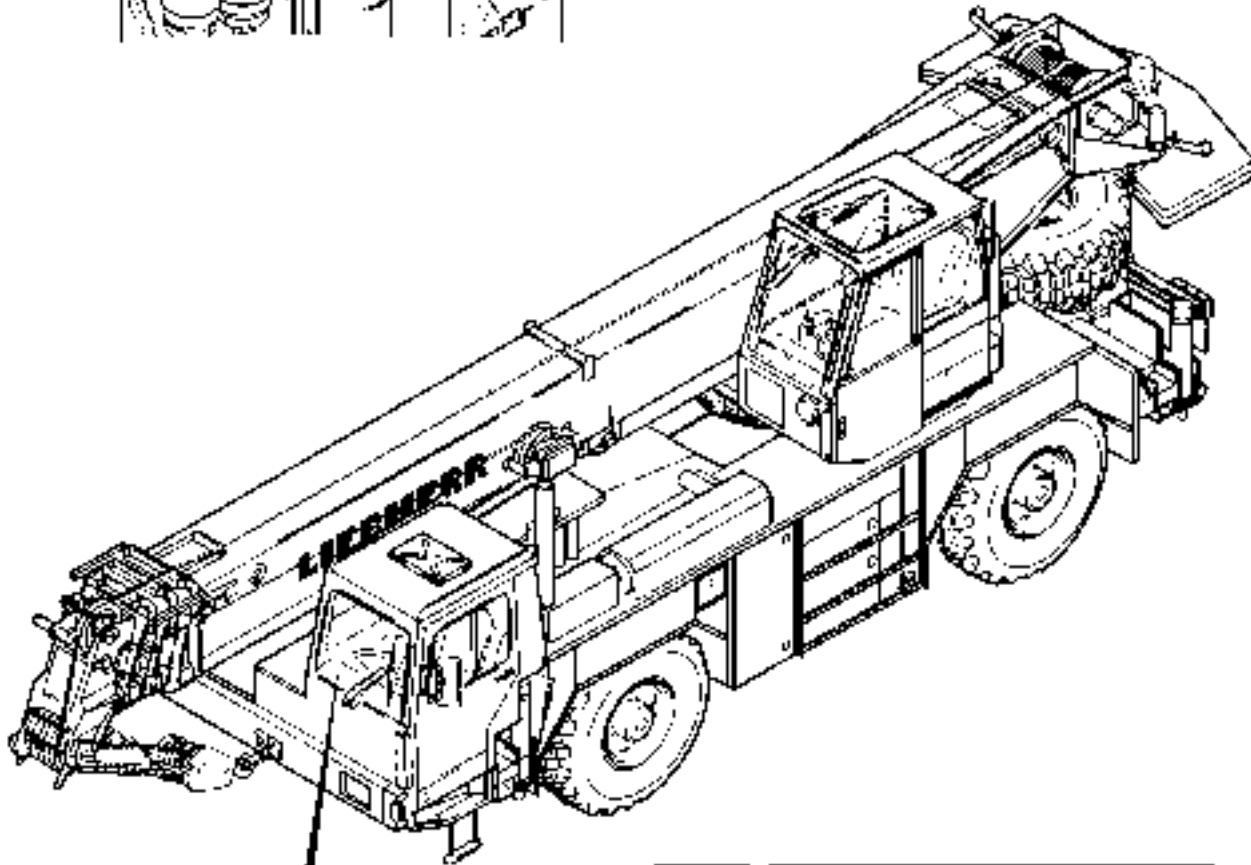
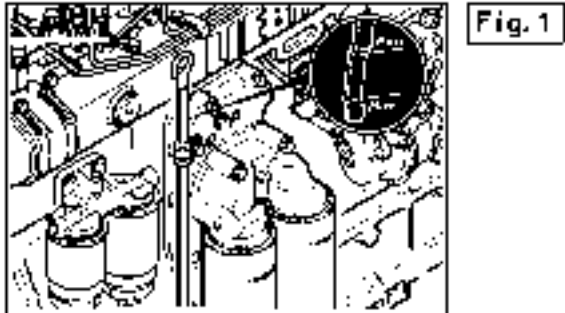

Oil level in the power shift reversing gearbox (Fig. 2)**Check the oil level**

- with the crane standing horizontally.
- with the engine running, approx. 1000 rpm.
- with the transmission in "N".

Turn the dipstick counterclockwise and remove.

Note: If the oil is cold, it must be between the MIN. and MAX. markings which apply to this temperature range; or at 80 °C, between the MIN. and MAX. markings which apply to this temperature range.

CAUTION: If the oil level has fallen below the MIN. marking which applies to these temperatures, engine oil **MUST** be refilled according to the lubrication table until it reaches a level between the MIN. - MAX. markings.
If it is not refilled, the transmission could be damaged.

Insert dipstick and turn clockwise.

Changing the oil

- Drain old oil.
- Refill with oil as specified in the LUBRICATION TABLE.
- Start the engine, idle rpm.
- Transmission in neutral "N".
- Refill with oil to the MIN. marking.
- Firmly brake the crane.
- Shift through all gears.
- Check the oil level again - if necessary, refill until it is to the MIN. marking.

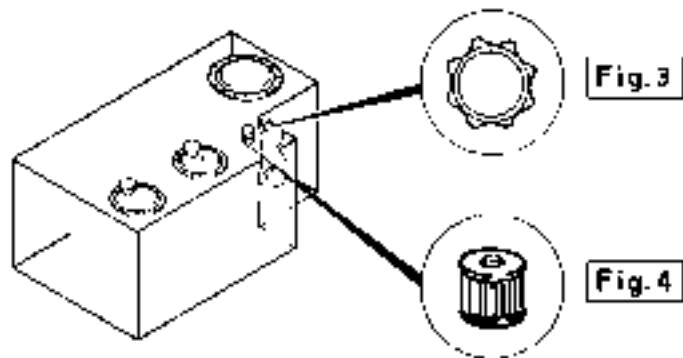
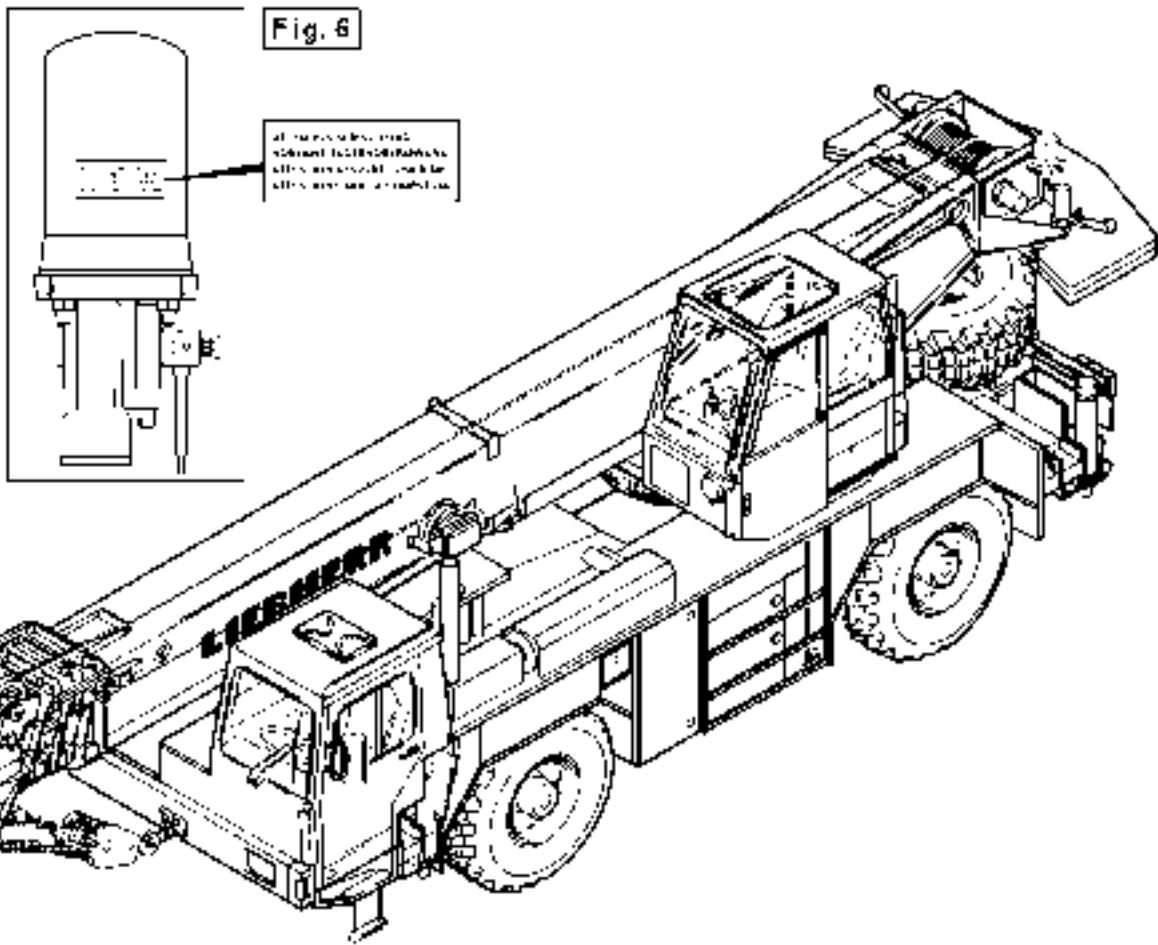
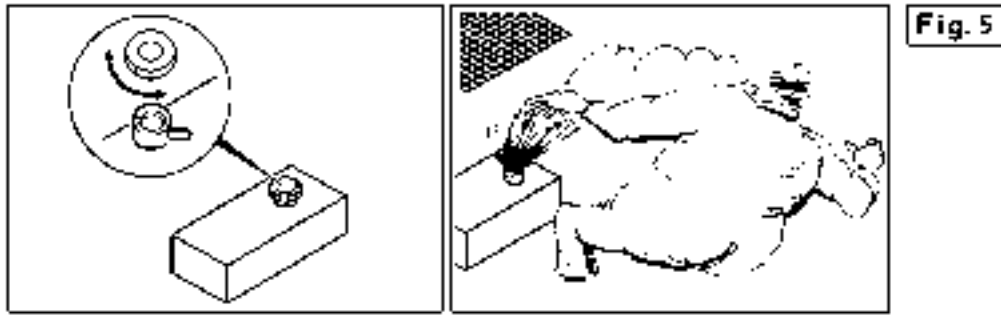

Oil level hydraulics (Fig. 3)

The oil level must be in the center of the upper oil level sight-glass

Note: Upper oil level sight-glass = max. oil level
Lower oil level sight-glass = min. oil level

CAUTION: If no oil level is visible in the upper oil level sight-glass, hydraulic fluid **MUST** be refilled immediately with fluid in accordance with the LUBRICATION TABLE until the fluid is visible in the middle of the sight-glass.
If the fluid level is too low, the pumps could be damaged.
When checking the oil level, the support jacks, the sliding arms, the luffing cylinder as well as the telescoping cylinder must be completely retracted. In an extended condition there is a danger of overfilling. When retracting the jack, oil is discharged through the bleed air openings. If the jacks are retracted too quickly, the oil pan can be damaged.

Aeration and bleed air filter (Fig. 4)

- Open cap with turn-lock fastener and check filter for contamination (visual inspection).

Note: If the filter is extremely dirty, it must be changed.

- Replace the cap.

Engine coolant (Fig. 5)

DANGER: The coolant must only be checked when the engine is cold.
Otherwise, there is the risk of skin burns!

- Turn the locking cap of the filling nozzle on the radiator compensator reservoir one notch and relieve excess pressure.
- Remove locking cap.
- If necessary, add coolant according to the lubrication chart until it runs over.
- Reinstall the radiator cap and tighten.

CAUTION: Refill the radiator tank only via the filling nozzle!
If any coolant has been lost, the coolant must be replaced in the same ratio!

Note: The radiator compensator reservoir must be topped up with coolant only at the filler neck, according to the LUBRICATION CHART.

Mixture ratio: 50 % volume anticorrosive / antifreeze
50 % volume make-up water

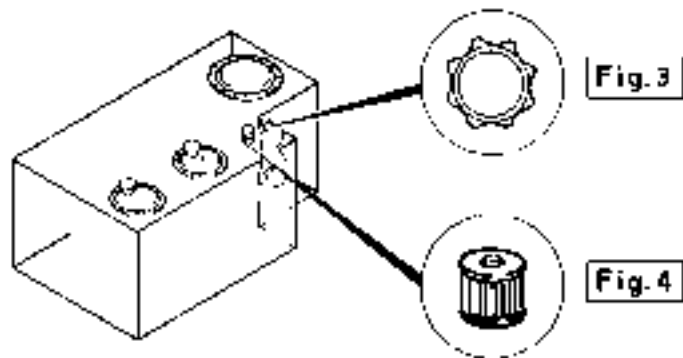
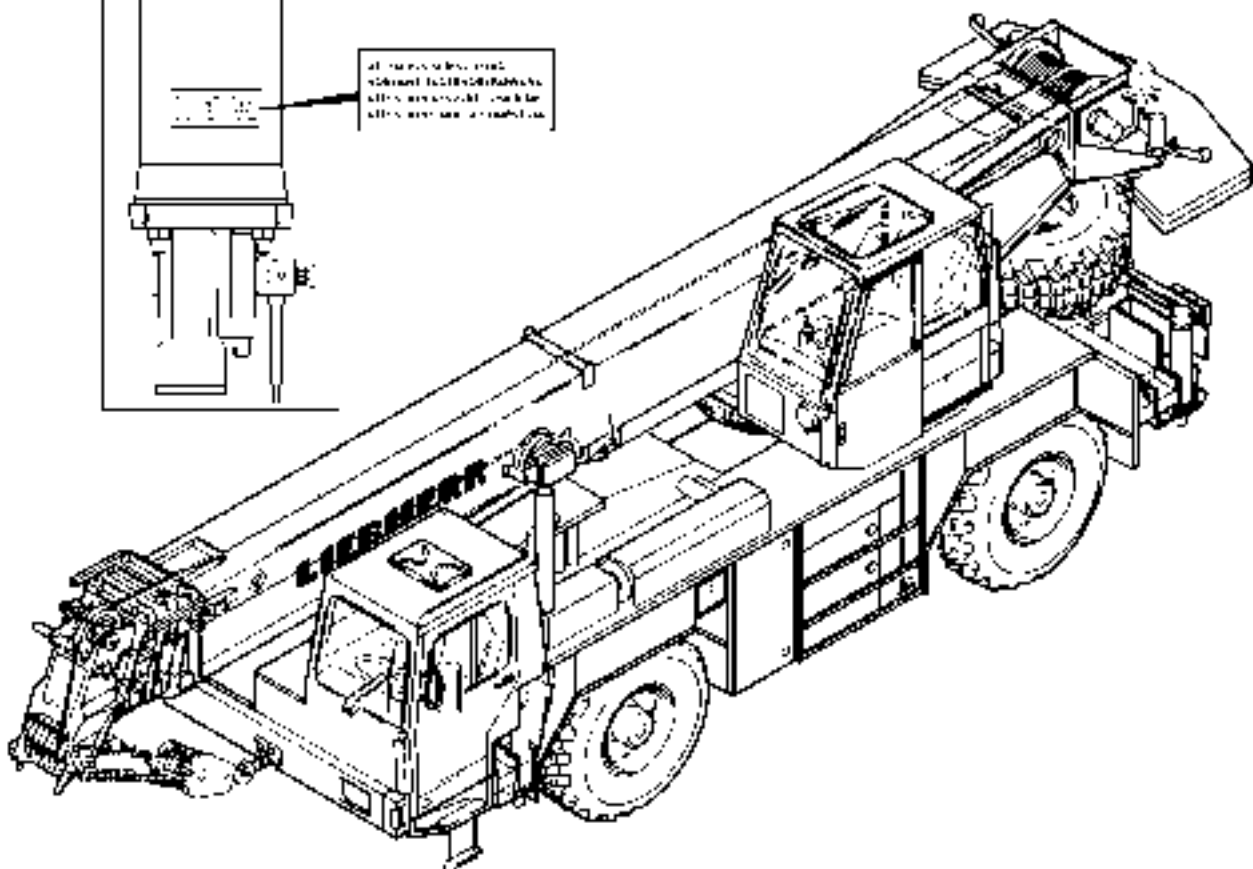
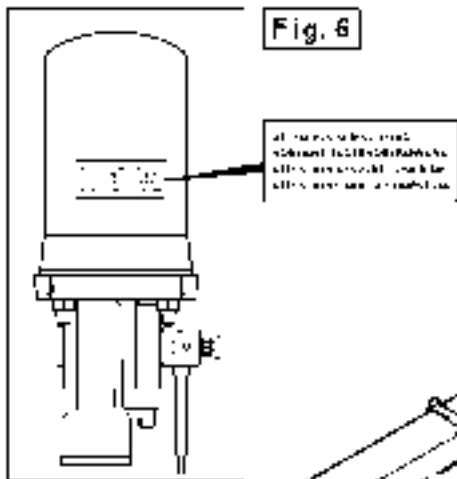
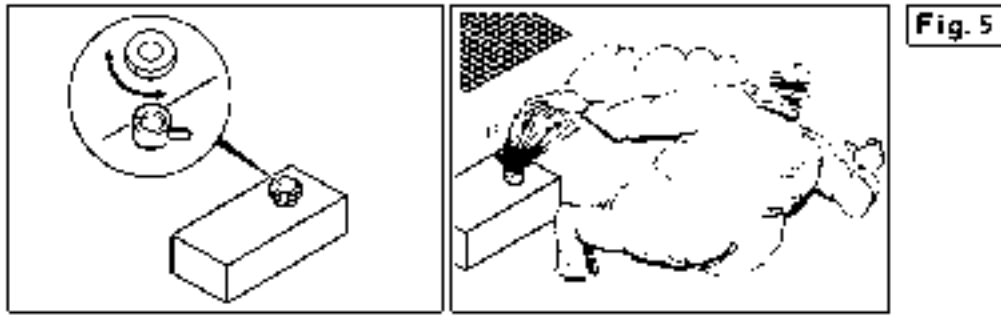

Air-dryer pressurized air-brake system (Fig.6)

The air-dryer of the pressurized air-brake system is maintenance-free.
The cartridges should be replaced annually.

CAUTION: The cartridges are kept in place by means of springs.

Hydraulic hose lines

The operational safety of the hydraulic hoses must be checked at least once per year by a competent person.

Replacing the hose lines

The hose lines must be replaced at appropriate intervals.

On the basis of our experience we recommend the following maximum periods of use for mobile cranes:

- in hard loading and unloading operation
with high operating temperatures and frequent movement cycles approx. 3 years
- in loading and unloading operation approx. 6 years
- in assembly operation with infrequent maximum output approx. 12 years

CAUTION: The hoses of the suction ducts of the oil containers must undergo a monthly visual inspection for tearing and damage, and be replaced if necessary.

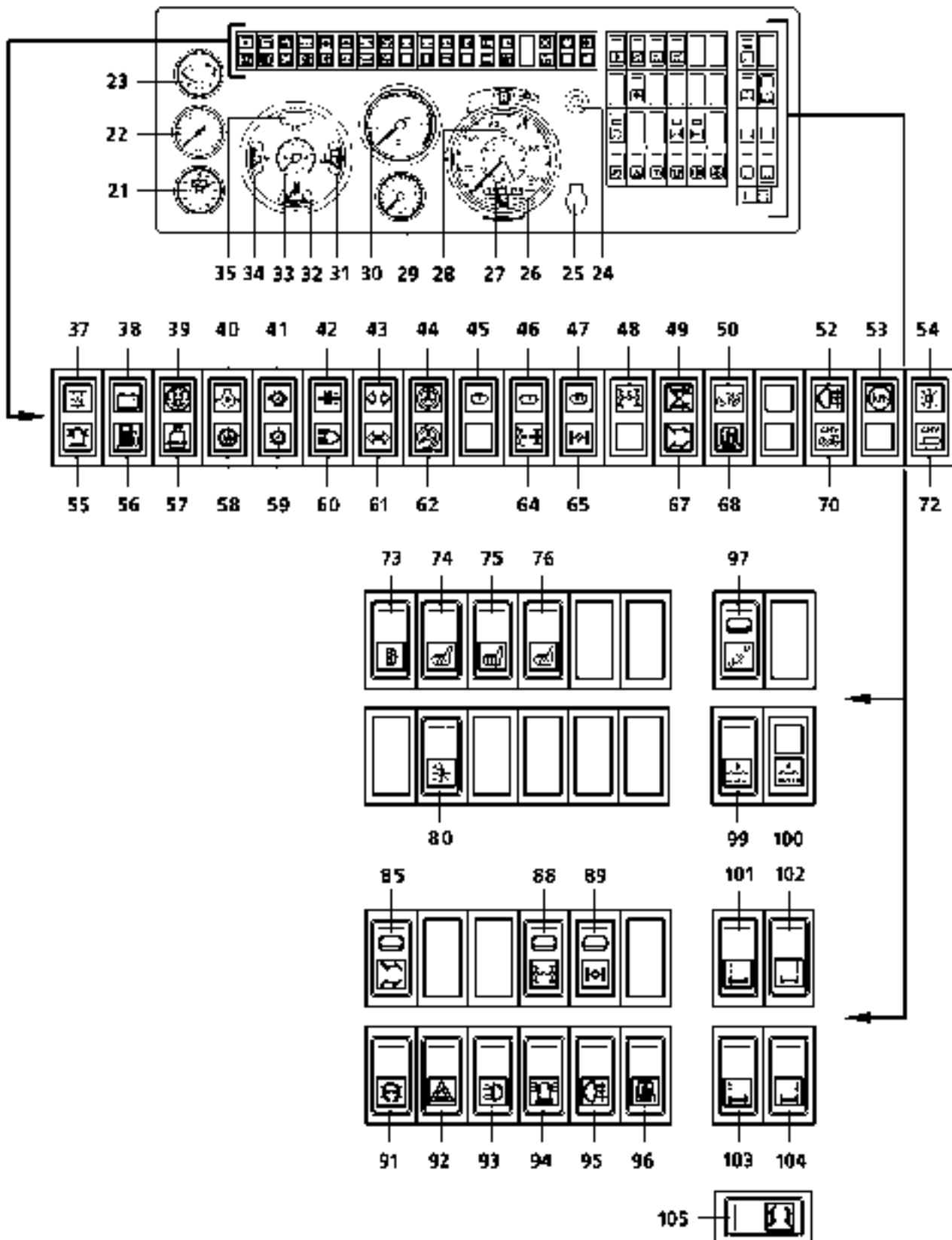

Axle suspension / locking system

The preload pressure of the 4 diaphragm reservoirs of the axle suspension system must be 40 bar.

CAUTION: In extremely varying ambient temperatures, for example after moving the crane to countries with extremely warm or cold temperatures, as well as in significantly varying summer and winter temperatures you must check and adjust the gas reservoir pressures.

If the gas preload pressure is too low, the diaphragms can be stressed and damaged. If the gas preload pressure is too high, the spring action of the vehicle's axle suspension can no longer be assured and cause damage to the vehicle.

The preload pressure of each diaphragm reservoir must be measured individually, as follows:

- Switch the changeover switch (97) to axle suspension "spring- suspended".
- Press the key buttons (101, 102 and 103, 104) to the rear until the oil has drained from the diaphragm reservoirs.
There must be no pressure in the axle suspension / locking system.
- Check the preload pressure with the aid of a testing and inflating device, and correct if required.

DANGER: On no account may air or oxygen be used to inflate the diaphragm reservoirs. **DANGER OF EXPLOSION!**

The pressure in the nitrogen bottle must not exceed the maximum permitted operating pressure of the reservoir or pressure gauge. Otherwise a pressure reducing device must be connected between bottle and inflating device.

- After the check has been carried out, operate the "LEVEL" key button (99) until indicator lamp (100) comes on.
The axle suspension cylinder automatically adjusts the vehicle to the appropriate level for on-road driving.

Axles

When checking the oil level, the following must be observed:

Axle bridges: The oil level must be up to the lower edge of the inspection port - if required, refill.

Wheel hubs: Turn the wheel so that the oil discharge screw is at its lowest point. Remove the stops from the filling and inspection port.
The oil level must be up to the lower edge of the inspection port - if required, refill with oil in accordance with the LUBRICATION TABLE.

CAUTION: When working on the axles, extreme cleanliness must be ensured so that no dirt is able to enter the internal spaces of the axles.

Tires

Check the tires for damage (including the spare tire). The profile depth (including the spare) may not fall below the minimum depth as prescribed by law.

The air pressure (including the spare) must correspond to the air pressure as given for those tires being used.

Note: Refer to chapter 1.03 "TECHNICAL DATA" for proper tire pressure.
The tires must be cold to be checked properly.

DANGER: **There is an increased risk of accidents if the tires are damaged, if the profile depth is too low, or if the tires have different pressures.**

Track adjustment

The track adjustment must be checked regularly. If these checks are not carried out, increased tire wear can occur. If particularly high strain occurs, eg. through bumping against the curb, it is then urgently necessary to check the track adjustment.

Note: **The track adjustment can only be carried out by trained personnel.**

Safety and maintenance notes for wheel discs (rims)

The following safety and maintenance notes are recommendations of the manufacturer that should be adhered to prevent safety risks that result from damaged rims. In addition, the manufacturer's warranty is only valid if these notes are observed and adhered to.

The wheel is one of the most important safety components of the entire vehicle. For that reason, the following points must be observed. When changing the tires, the wheels, the rims, and the nave are all to be inspected for the following:

- excessive rust or corrosion
- bent rim flanges
- cracks in the rim
- cracks in the wheel dish
- damage to the sides and lock rings
- damage to the lug nuts or bolts
- deformed bolt holes
- correct fitting of rim components

If damaged rim components are discovered, these must be removed and replaced by new components. If chipped paint or minor rust is discovered, the rust layer may be removed and the wheel repaired by applying a coat of commercially available paint. When doing this, ensure that the surface is smooth, especially on the tire seat surface.

DANGER: **Any welding on rims and dishes, especially repairing deformed bolt holes and replacing the whole wheel center is prohibited.**
Disc wheels with defects of this nature must be scrapped at once. Repair work on these highly-stressed parts of the disc wheel causes structural changes in the material, and this can lead to sudden fractures.

Electrical system, lighting

Maintenance work on the electrical system is basically restricted to changing defective fuses, bulbs and taking care of the batteries.

CAUTION: Defective fuses must only be replaced with those of the same amperage. Bypassing a fuse with a wire, for example, is prohibited. This could cause damage to the electrical system.

The batteries must be kept clean and dry. Dirty terminals should be removed, cleaned and greased with acid-free, acid-resistant grease.

Never let oil or grease come into contact with the sealant.

CAUTION: Never lay tools on the batteries, and keep open flames at a distance. The batteries must never be disconnected while the engine is running as this will destroy the generator.

Note: The acid level in the batteries must be checked at least once a month, and at least once a week in summer and in warm climates.

The acid level must be approx. 15 mm above the plate edge; if necessary, top up with distilled water.

CAUTION: Do not use a metal funnel.

The vent holes in the screw-on cell covers must always be kept free.

If distilled water is used, wait half an hour after topping up and then measure the acid density. When doing this, the acid temperature should be as close to + 20 °C as possible.

Spec. weight [kg/dm ³]	Charge
1.28	well charged
1.20	half charged; recharge
1.12	discharged; charge immediately

Especially in cold weather ensure that the batteries are well-charged as their efficiency is reduced and more current is required.

CAUTION: If the batteries have to be recharged, this must be done with direct current only, and the current strength must never be more than 1/10 of the batteries capacity.

Example: To charge a battery of 143 Amps, the charging current must not exceed 14.3 Amps.

CAUTION: When working on the crane's electrical system, and whenever any welding is being carried out, the batteries must be separated from the current circuit at the battery main switch.

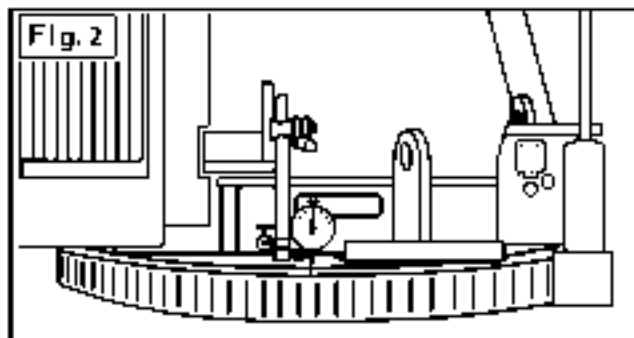
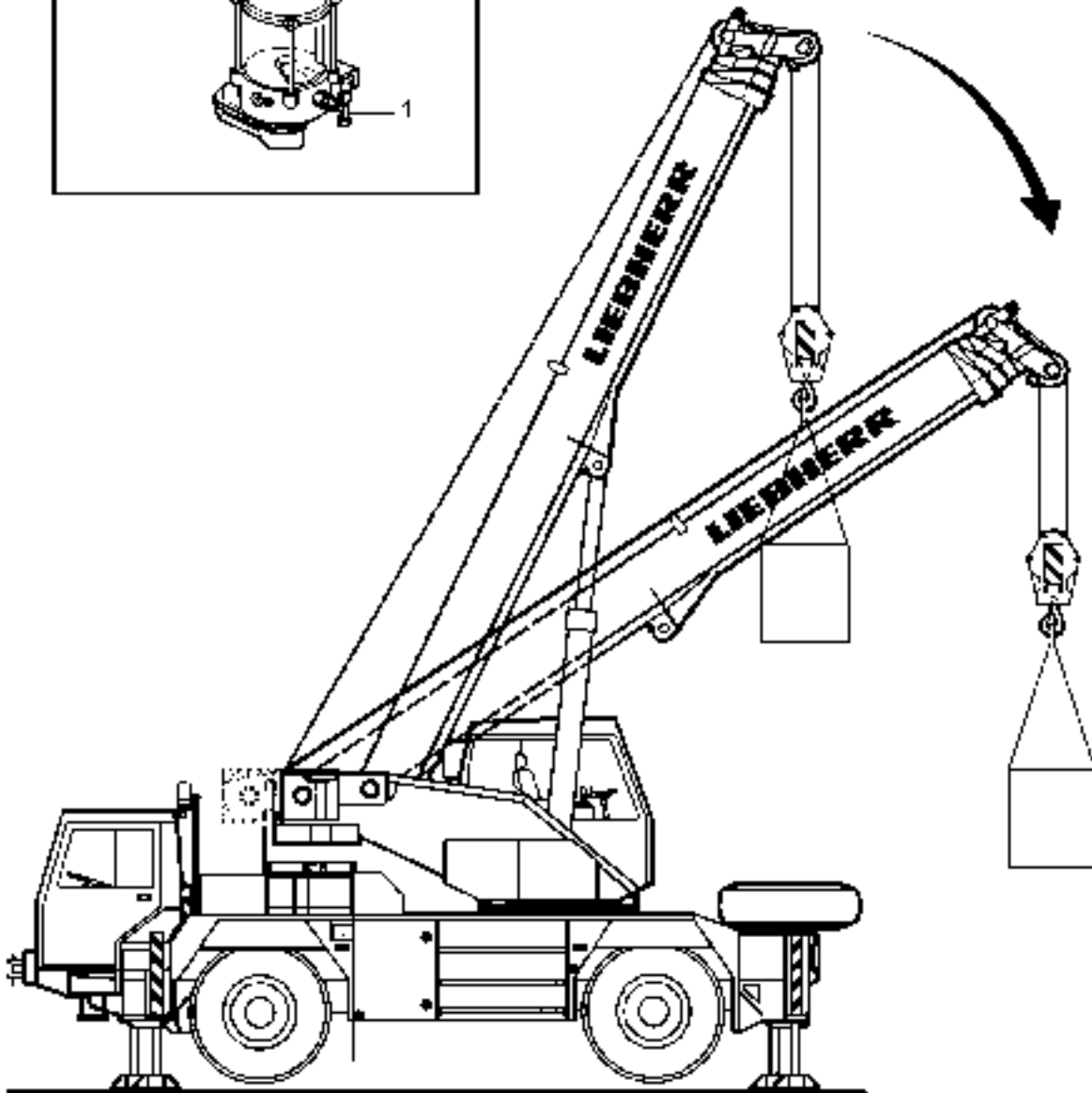
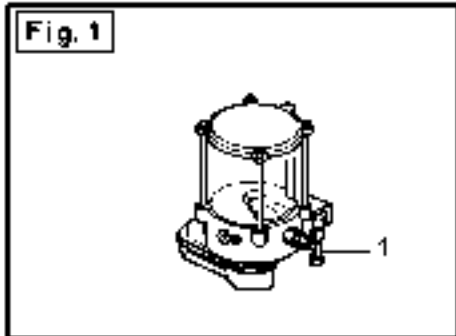

Rotary connection with central lubrication system (fig. 1)

The crane superstructure is equipped with a central lubrication system. All grease points on the rotary connection, the bearings of the pivot section, the bearings of the luffing cylinder and the hoist winches are supplied with the correct amount of grease depending on the operating hours.

The lubrication time is about 2 minutes, in 3 hour intervals.

C A U T I O N : the intervals time must be set to 3 hrs.

Note: Please refer to the attached, more detailed description of the BEKA-MAX central lubrication system.

Access to the automatic central lubrication system.

- Turn the ignition on and use the supplied magnetic universal key and hold it on the red point (reed contact in the control) to initiate additional lubrication and / or to refill the grease lines with grease after a repair.

C A U T I O N : Make sure that the grease container is constantly filled with grease as specified on the lubrication chart.

Afert every repair on grease lubricated components, refill the grease lines by pressing the illuminated push button*.

If this is not observed, the component can rus dry.

If the crane is not being moved for a period longer than 3 months, then it must be lubricated with an external grease pump on the grease fitting block (Pos. 1), until grease emerges on all lube points.

The repeat the corresponding crane movement several times and repeat the lubrication procedure.

- Clean the slewing ring externally and grease it.

Check the maximum tilt play

The maximum tilt play is 2.7 mm

Checking procedure:

- Support the crane properly to the wide support base.
- Adjust the overload safety device to the equipment configuration of the crane according to the 360° load capacity chart.
- Place the gauge in such a way that the test pin is right next to the sealing edge on the geared ring (fig. 2)
- Bring the boom to the steepest position and set the test gauge to "0".
- Bring a load to maximum permissible working radius, according to the load capacity chart and read the gauge.
- Repeat the test every 90°.

D A N G E R : If the maximum tilt play is exceeded, there is the danger that the slewing gear will break away and separate and the crane will topple over.

Slewing platform ballast (additional ballast, auxiliary ballast)

After the first 1,000 kilometers it must be checked that the attaching screws are securely seated. Further, every 10,000 km or 400 operating hours the secure seating of the screws must be checked.

D A N G E R : **If this is not done, it cannot be ensured that the slewing platform ballast is properly secured.**
Oscillating movements which occur during travel can lead to metal fatigue of the screws, which can then break.
The result is that the slewing platform ballast falls off.

Slewing gear transmission

With the slewing gear at a standstill, check the oil level in the sight-glass.

C A U T I O N : **Loss of oil indicates damage or a malfunction. This must be rectified immediately.**

Hoisting gear transmission

Check seal (visual inspection)

C A U T I O N : **Loss of oil indicates damage or a malfunction in the hoisting gear. This must be rectified immediately.**

Hydraulic hose lines

The operational safety of the hydraulic hoses must be checked at least once per year by a competent person.

Replacing the hose lines

The hose lines must be replaced at appropriate intervals.

On the basis of our experience we recommend the following maximum periods of use for mobile cranes:

- in hard loading and unloading operation
with high operating temperatures and frequent movement cycles approx 3 years
- in loading and unloading operation approx 6 years
- in assembly operation with infrequent maximum output approx 12 years

C A U T I O N : **The hoses on the suction ducts of the oil pan must be visually inspected monthly for tears and damage, and if required, changed.**

Diaphragm reservoirs of the hydraulic system

The following diaphragm reservoirs are installed in the hydraulic system:

- control pressure control bar 10 bar
- control pressure base block 8 bar
- control pressure lower hoisting gear 12 bar
- control pressure slewing gear (2 reservoirs) each 9 bar
- ballasting (2 reservoirs) each 40 bar

It is important that the preload pressure noted in the hydraulic schematic and on the reservoirs is available. Check the pressure in each diaphragm reservoir.

CAUTION: In extremely varying ambient temperatures, for example after moving the crane to countries with extremely warm or cold temperatures, as well as in significantly varying summer and winter temperatures you must check and adjust the gas reservoir pressures.

Requirements:

- Crane hydraulic system (or engine) is stopped. This reduces the pressure on the fluid side of the diaphragm reservoirs.

Check the preload pressure with the aid of a testing and inflating device, and correct if required.

DANGER: On no account may air or oxygen be used to inflate the diaphragm reservoirs.
DANGER OF EXPLOSION!
The pressure in the nitrogen bottle must not exceed the maximum permitted operating pressure of the reservoir or pressure gauge. Otherwise a pressure reducing device must be connected between bottle and inflating device.

Note: The national regulations on pressure vessel inspection must also be followed.

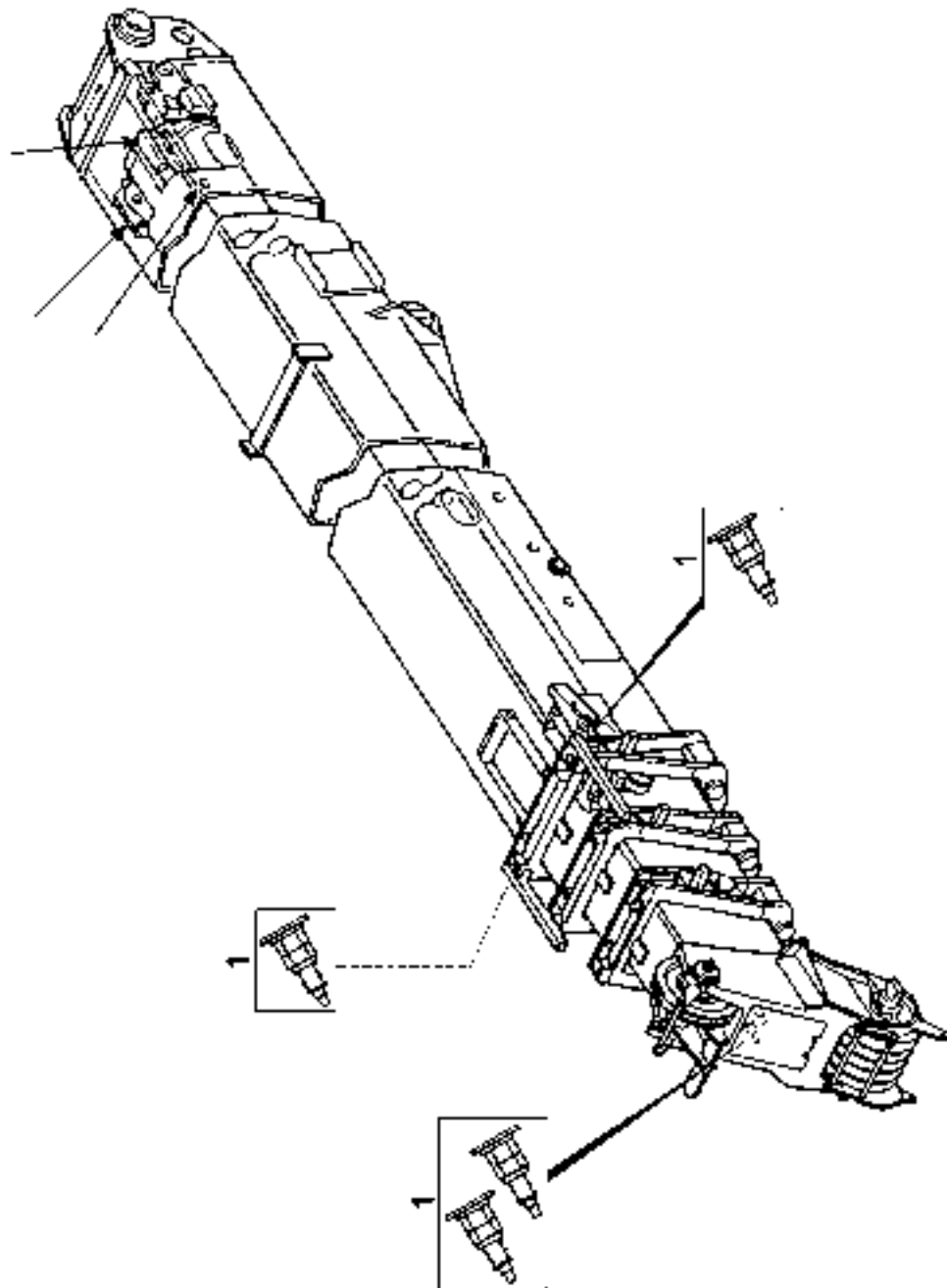

LT L 1025
LTM 1025
LIM 1040
180303

Telescopic boom

The inner sliding surfaces of the telescopic boom are greased via the grease nipples in the bearing pads. The grease nipples are accessible from the outside through inspection ports on both sides of the telescopic boom when the telescopic sections are extended to 66,6% or 90%.

Special grease must be used for the internal and external sliding surfaces of the telescopic boom.

Telescoping cables

When telescopic section I is extended with the telescopic ram, telescopic sections II and III are simultaneously extended by a cable mechanism.

Extension of telescopic section II is carried out by a quadruple (4x) flat cable (telescoping cable).

Extension of telescopic section III takes place via two 2x flat cables (telescopic section).

Retraction of telescopic sections II and III is carried out by three retracting cables.

There are several inspection ports on both sides of the telescopic sections which allow the telescoping and retracting cables to be checked during operations without having to dismantle the boom.

C A U T I O N: New cables must be of the same design, strength rating and diameter as the original cables.

The telescoping cable (flat cables) must be exchanged in pairs.

Maintenance

In addition, the telescopic boom should be dismantled after 20,000 operating hours, or approx. 10 years, so that a complete inspection of the bearings, telescoping and retracting cables, cable pulleys, and the telescoping cylinder can be thoroughly carried out.

The telescoping cables are held taut by means of the retracting cables.

If tautness diminishes due to the cable twisting over time, the retracting cables must be readjusted to the original tautness.

Retightening the retracting cable

Extend telescopic sections II and III 1 m and tighten the retracting cable on both sides with the adjustment screws (1) until the retracting cable is tight on both sides.

Make a visual inspection through the inspection ports on the sides of the telescopic sections.

The retracting cable should not hang lower than 10 cm over the entire length of the boom.

C A U T I O N:

- 1. When tightening the screws (1), the retracting cable must not be turned.**
- 2. After each tightening procedure, retraction synchronization of telescopic sections II and III must be checked.**

Checking synchronization

Carefully retract telescopic sections I, II and III. The stop of telescopic section II must first come to its rest.

If this is not the case, the stop of telescopic section II must be strengthened or the stop of telescopic section III must be reduced.

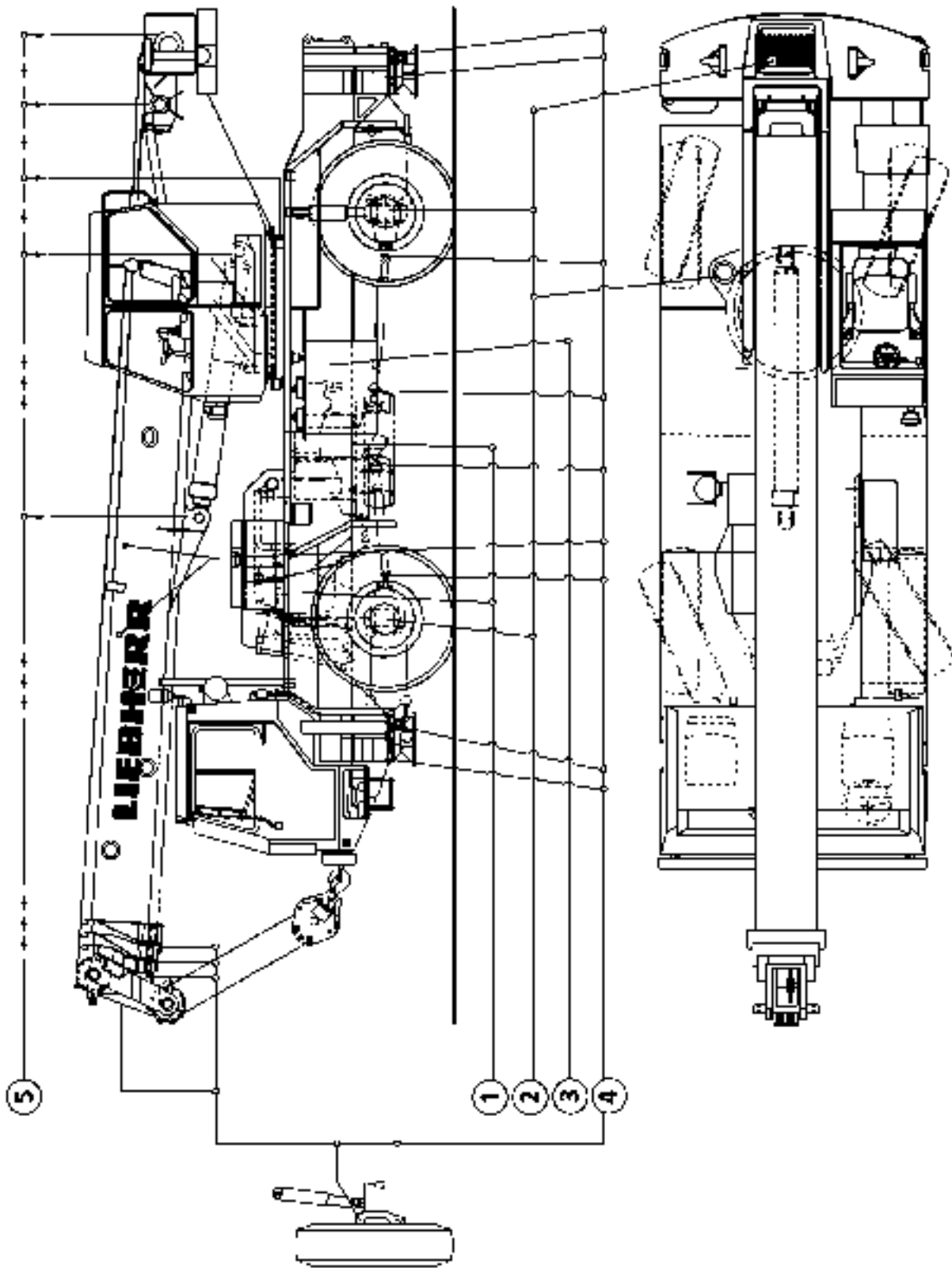

	approx. liter
Vehicle engine D 916 TI Engine oil Coolant	20 38
Fuel tank Diesel fuel	300
Power shift reversing gearbox Engine oil	28
1st axle Gear oil axle drive each wheel side	13.5 1.3
2nd axle Gear oil axle drive each wheel side	13.5 1.3
Hydraulic fluid reservoir * ATF	340
Slewing gear transmission synthetic Gear oil	1.5
Hoisting gear drive synthetic Gear oil	2.0
Central lubrication system Special grease	2 kg

CAUTION: The given quantities are only orientation values.
All filling requirements must be carried out and fulfilled according to the markings on the dip sticks, the glass view ports, etc.

* When checking the oil level, all hydraulic jacks must be retracted. The upper markings on the view ports must not be exceeded.

CAUTION: Synthetic oils may not be mixed with mineral oils!

Explanation to the lubrication plan:

- 1 Engine oil
- 2 Gear oil
- 3 ATF
- 4 Grease
- 5 automatic grease supply via the central lubrication system

SCHMIERSTOFFTABELLE FÜR FAHRZEUGKRANE
TABLE OF LUBRICANTS FOR AUTOMOTIVE CRANES
TABLE DE LUBRIFIANTS POUR GRUES AUTOMOTRICES

A C H T U N G: Synthetische Öle dürfen nicht mit Mineralölen gemischt werden!

C A U T I O N: Do not mix Synthetic oils with mineral oils!

A T T E N T I O N: Ne pas mélanger huiles synthétiques avec huiles minérales!

Der Temperaturbereich von -45 °C bis +10 °C erfordert eine Sonderausführung.

Special lubricants are required for a temperature from -45 °C to +10 °C.

Le domaine de températures de -45 °C jusqu'a +10 °C nécessite des lubrifiants spéciaux.

ÖL- UND FETTBEFÜLLUNG OIL AND GREASE FILLING REPLISSAGE D'HUILE ET DE GRAISSE			
	Verwendungszweck Intended use Application	Deutsche Öle und Fette, Werks-Erstbefüllung German oils and greases, original works filling Huiles et graisses allemandes, remplissage original usine	
		- 20 °C → + 50 °C	- 45 °C → + 10 °C
1	Dieselmotoren diesel engines moteurs Diesel Ölbadluftfilter oilbath air cleaner filtre à air bain d'huile	SAE-HDC 15 W-40 API-CD/CE/CD+ (SHPD) CCMC-D4/D5 MIL-L-2104 E Pourpoint - 33 °C Flammpunkt 230 °C bis - 15 °C ohne Vorwärmung up to without preheating jusqu'à sans préchauffage bis - 30 °C mit Vorwärmung up to with preheating jusqu'à avec préchauffage	SAE-HDC 10 W-30 API-CD/CE/CD+ (SHPD) CCMC-D4/D5 MIL-L-2104 E Pourpoint - 33 °C bis - 36 °C Flammpunkt 210 °C bis - 20 °C ohne Vorwärmung up to without preheating jusqu'à mit Vorwärmung bis - 45 °C mit Vorwärmung up to with preheating jusqu'à avec préchauffage
2	Antriebsachsen mit Differentialen, Planetengetrieben und angebautem Verteilergetriebe driving axles w. differ., planetary gears and flanged transfer case essieux moteurs à différentiel, réducteurs planétaires et boîte transfert ZF Achsantieb DK-7 / axle drive ZF DK-7 entraînement des essieux ZF DK-7	HYPOID Getriebeöl SAE 90 EP GL 5 / MIL-L-2105 B Pourpoint - 24 °C Flammpunkt 210 °C	SAE 75 W-80 EP GL 5 / MIL-L-2105 B Pourpoint - 45 °C Flammpunkt 210 °C
3	ZF Synchron oder Allklauengetriebe (5 K-110 GP oder AK.6-90) ZF synchromesh or manual gears ZF synchromesh ou boîtes manuelles	Mehrzweck Getriebeöl SAE 80 MZ GL 4 / MIL-L-2105 Pourpoint - 32 °C Flammpunkt 210 °C	ATF 86 DEXRON II D / C4 / ZF TE - ML 14 Pourpoint - 45 °C Flammpunkt 200 °C
4	ZF Lastschaltgetriebe (WG 120 / 150 / 180 / 181 / 200 / 201) ZF power shift gears ZF boîtes de vitesse et d'inversion ALLISON Versatzgetriebe (drop box) ALLISON drop box ALLISON decaleur de boîte de transfert CLARK Lastschaltgetriebe CLARK power shift gears CLARK boîtes de vitesse et d'inversion	SAE-HDC 15 W-40 MIL-L-2104 C (SHPD) Pourpoint - 33 °C Flammpunkt 230 °C bis - 30 °C, 10 min Getriebedurch- lauf nach Start unter - 25 °C up to - 30 °C, 10 min circulation after starting below - 25 °C jusqu'à - 30 °C, 10 min de circulation après démarrage sous - 25 °C	ATF 86 DEXRON II D / C4 / ZF TE - ML 14 Pourpoint - 45 °C Flammpunkt 200 °C max. Öltemperatur 130 °C mit Vorwärmung unter - 35 °C with preheating below - 35 °C avec préchauffage sous - 35 °C
5	Automatikgetriebe automatic transmissions boîtes de vitesses automatiques ZF HP 500 / 600 ZF 6 WG 251 ALLISON CLBT 740 / 750 / 754 / 755	ATF 86 DEXRON II D / C4 / ZF TE - ML 14 max. Öltemperatur 130 °C Pourpoint - 45 °C Flammpunkt 200 °C	ATF 86 DEXRON II D / C4 / ZF TE - ML 14 max. Öltemperatur 130 °C Pourpoint - 45 °C Flammpunkt 200 °C mit Vorwärmung unter - 35 °C with preheating below - 35 °C avec préchauffage sous - 35 °C
6	Fahrzeug Verteilergetriebe / transfer box / boîte de transfert STEYR PUCH (VG 1200 / 1600 / 2000) KESSLER (VG 1800) STEYR PUCH Versatzgetriebe (drop box) STEYR PUCH drop box / decaleur de boîte de transfert KESSLER Zwischengetriebe (VG 1200) KESSLER intermediate gears / transmissions intermédiaires Pumpen-Verteilergetriebe pump transfer cases / boîtes transfert de pompes Bergewinden / recovery winches / treuils de remorquage	HYPOID Getriebeöl SAE 90 EP GL 5 / MIL-L-2105 B Pourpoint - 24 °C Flammpunkt 210 °C	SAE 75 W-80 EP GL 5 / MIL-L-2105 B Pourpoint - 45 °C Flammpunkt 210 °C

ÖL- UND FETTBEFÜLLUNG OIL AND GREASE FILLING REPLISSAGE D'HUILE ET DE GRAISSE			
	Verwendungszweck Intended use Application	Deutsche Öle und Fette, Werks-Erstbefüllung german oils and greases, original works filling Huiles et graisses allemandes, remplissage original usine	
		- 20 °C → + 50 °C	- 45 °C → + 10 °C
7	Seilwinden, Drehwerksgetriebe winches, slewing gears treuils, mécanismes d'orientation	AVILUB VSG 220 PG 220 DIN 51502 (synthetisch) Pourpoint - 45 °C Flammpunkt 210 °C	AVILUB VSG 68 PG 68 DIN 51502 (synthetisch) Pourpoint - 51 °C Flammpunkt 242 °C
8	Kranhydraulik für Kranoberwagen Hydraulik für Unterwagenabstützungen und Lenkung ZF Halbblocklenkung und ZF Winkelgetriebe crane hydraulics for superstructure hydraulics for outriggers and power steering ZF semi-integr. steering gear and ZF angular gear for steering hydrauliques pour tourelle hydrauliques pour stabilisateurs et direction ZF direction à semibloc et engrenage angulaire ZF pour direction	ATF 86 DEXRON II D / ZF TE - ML 14 max. Öltemperatur 90 °C Pourpoint - 45 °C Flammpunkt 200 °C	Sommer / summer / été: ATF 86 DEXRON II D / ZF TE - ML 14 max. Öltemperatur 90 °C Winter / winter / hiver: ATF 44 M max. Öltemperatur 50 °C Pourpoint - 54 °C Flammpunkt 125 °C
9	Scheibenbremsanlage disk brake system système de frein à disque	Bremsflüssigkeit brake fluid liquide de frein SAE J 1703 e DOT 4	ATE Arktis 3.9901-5503.2 max. Öltemperatur 100 °C Naßsiedepunkt 145 °C boiling point point d'ébullition
10	Gleitlagerungen, wälzgelagerte Gelenke friction bearings, joints on rolling bearings des paliers, articulations à palier Zentralschmieranlage Kranoberwagen centralized lubricating system crane superstructure graissage central partie tournante	LIEBHERR Spezialfett 9610 Spezifikation: KP 2 K (-30) EP 2 Identnummer: 861301308	LIEBHERR Spezialfett 1026 Spezifikation: KP 2 G (-50) (NATO Code: G 403) Identnummer: 861303708
11	Gelenkwellen, Drehkranz-Wälzlagerungen cardan shafts, slewing ring rolling bearings arbres articulés, paliers couronnes d'orientation	LIEBHERR Spezialfett 9610 Spezifikation: KP 2 K (-30) EP 2 Identnummer: 861301308	LIEBHERR Spezialfett 1026 Spezifikation: KP 2 G (-50) (NATO Code: G 403) Identnummer: 861303708
12	Drehkranzschrauben (nur bei Montage) ≤ M 48 slewing ring bolts (only at assembly) boulons pour couronne d'orientation (seulement lors montage) Drehkranzschrauben (nur bei Montage) ≥ M 56 slewing ring bolts (only at assembly) boulons pour couronne d'orientation (seulement lors montage)	LIEBHERR Montagefluid 907 Gleitmo 100 S oder OKS 220	LIEBHERR Montagefluid 907 Gleitmo 100 S oder OKS 220
13	Zentralschmieranlage Kranfahrgestell centralized lubricating system crane chassis graissage central châssis porteur	LIEBHERR Spezialfett 904 Bio Spezifikation: MP 00 G (-50) Identnummer: 861303808	LIEBHERR Spezialfett 904 Bio Spezifikation: MP 00 G (-50) Identnummer: 861303808
14	Gleitlagerungen der Teleskopausleger (Kunststofflager) Schiebeholme, Fleyerketten in Schiebeholmen sliding bearings of telescopic boom (synthetic) outriggers, Fleyer chains in outriggers paliers de guidage-flèche télescopique (synthétique) stabilisateurs, chaînes Fleyer aux stabilisateurs	LIEBHERR Spezialfett 9613 Spezifikation: KP 2 G (-30) LS Identnummer: 861303608	LIEBHERR Spezialfett 1026 LS Spezifikation: KP 2 G (-50) LS (NATO Code: G 403 LS) Identnummer: 861302608

ÖL- UND FETTBEFÜLLUNG OIL AND GREASE FILLING REPLISSAGE D'HUILE ET DE GRAISSE			
	Verwendungszweck Intended use Application	Deutsche Öle und Fette, Werks-Erstbefüllung german oils and greases, original works filling Huiles et graisses allemandes, remplissage original usine	
		- 20 °C → + 50 °C	- 45 °C → + 10 °C
15	Innengleitlagerung der Teleskopausleger (nur bei Erstmontage) internal slide bearing application of telescopic booms (only at initial assembly) guidage à glissement intérieur des flèches télescopiques (seulement lors du premier montage)	LIEBHERR Spezialfett 1336 mit Lösungsmittel LM (Sprühfett) Spezifikation: KP 2 G (-30) LS+LM Identnummer: 861303308	LIEBHERR Spezialfett 1336 mit Lösungsmittel LM (Sprühfett) Spezifikation: KP 2 G (-30) LS+LM Identnummer: 861303308
16	Offene Verzahnung der Drehkränze open toothing of slewing rings denture des couronnes d'orientation	AVILUB RHY	AVILUB RHY
17	Hydraulik in der LIEBHERR Arbeitsbühne LA 500 Hydraulik im Arbeitskorb hydraulics in LIEBHERR working platform LA 500 hydraulics in work cage hydrauliques dans plateforme d'entretien LIEBHERR LA 500 hydrauliques dans la nacelle Motorregulierung Oberwagenmotor engine speed control slewing platform engine reglage vitesse rotation du moteur de la partie tournante	ATF 86 DEXRON II D / ZF TE - ML 14 Pourpoint unter - 45 °C Flammpunkt 200 °C	ATF 44 Pourpoint unter - 54 °C Flammpunkt 125 °C
18	Kraftstofftank fuel tank réservoir de carburant	Sommerdiesel bis - 2 °C DIN 51601 sommer fuel / carburant d'été Winterdiesel bis - 15 °C DIN 51601 winter fuel / carburant d'hiver	Winterdiesel mit Frostflow (für auszuliefernde Geräte)
19	Kühlerfüllung für Dieselmotoren und Heizanlagen radiator filling for Diesel engines and heatings remplissage de radiateur pour moteurs Diesel et chauffages	bis - 40 °C up to AVIA-Frostschutz 50% jusqu'à Wasser 50%	bis - 45 °C up to AVIA-Frostschutz 60% jusqu'à Wasser 40%
20	Seile der Bergewinden ropes of the recovery winches câbles des treuils de remorquage	Eurol-TW-Fluid	Eurol-TW-Fluid

Chapter 8

Crane inspections

General

This crane has been inspected before delivery; in Germany according to trade regulations according to VBG 9, in other countries according to national guidelines and regulations.

The VBG stipulates an annual repeat inspection, in other countries, local and national regulations apply. If no other national regulations exist, then all repeat inspection should be completed according to VBG 9.

For load lifting components, such as cables, chains and load hooks, regulation according to VBG 9a applies. All guidelines given in these regulations must be observed for repeat inspections.

Repeat inspections of cranes must be made by expert personnel or personnel trained for mobile cranes.

Repeat inspections are generally visual inspections, where the condition of the crane as well as components is being evaluated by expert inspectors. These inspections are made to prevent accidents through early detection of problems.

Any problems found during these inspections must be documented, remedied and then reinspected.

Included are the careful inspection of the load moment limiter, the hydraulic and electrical controls and safety devices.

Below we have listed some important points, which must be observed during repeat crane inspections. We note that experts / inspectors are responsible for these inspections. For that reason, not all necessary inspections are listed in this chapter.

If you have any later questions for the inspector, contact our customer service department, who will contact the appropriate section at LIEBHERR-WERK EHINGEN GMBH and get back to you.

1. Inspection of load carrying steel members

The load carrying steel members, such as boom, slewing platform, chassis, support devices, such as sliding arms or outrigger supports must be checked at least during the annual inspection. Even though the welding seams are generally not in high stress areas, it is nevertheless important to check them during these repeat inspections.

We note DIN 15018, part 3, point 1, which gives stress values for highly resilient fine grain steel in load carrying steel members. They determine the service life of load carrying steel members. Service life, however, cannot be solely determined by stress values, but also depends on shock loads occurring during the service life of the machine. For that reason, the load carrying steel members and welding seams must be especially well checked by inspectors during the annual inspection.

If the crane has been subjected to extraordinary stress, for example an unusual shock, these load carrying components must also be inspected.

If any damage is found, such as cracks, etc. on any point of the steel construction, then the extend of the damage must be evaluated by experts in this field through material test methods, such as magnetic particle inspection, ultra sound or X-ray tests. Then experts must determine if and how the damaged section can be repaired by welding or by any other means.

2. Inspection of hoist and pull in winches, slewing gears and pump distributor gears

The hoist and pull in winches and slewing gears are closed planetary gear versions. All pump distributor gears using in crane operation are also closed gear versions. The gears are sized for high service life, drive shafts and gear wheels are also long lasting.

Even though gears are made for long service life, an external visual inspection is not sufficient in this case, because the service life can be influenced by insufficient maintenance (lack of oil), defective seals, improper operation or overuse. For that reason, the inspection must be made according to the following guidelines:

2.1 Inspections**2.1.1 Inspection intervals**

Every 1000 operating hours, at least once a year (annually)

2.1.2 Inspection

Check oil level. On hoist and pull in winches, we recommend to drain the oil and compare the amount with the stipulated oil quantity.

2.1.3 Check color of oil

If the oil is blackened and / or if the oil smells burnt, one can assume that the oil has been overheated, In that case, the oil must be changed.

2.1.4 Check for foreign particles

This test should be done in a qualified lab. The used oil is dropped onto specified filter paper. The oil sample is visually checked under a microscope for foreign particles. If any are found, then the oil must be checked by a lab for its components.

2.1.5 Evaluation of foreign particles found in oil

Maximum permissible foreign particle parts are 0.15% of the total oil quantity, by weight.

Maximum permissible foreign particle size from fine shavings to 0.25 my.

If the above values have been exceeded, remove the gear and check out the cause of increased contamination. Replace any damaged parts and fill the gear with new oil.

CAUTION: These repairs may only be made by expertly trained personnel.

2.1.6 Visual inspection

The gears must be checked for leaks, since any loss of oil - aside from environmental contamination - can also lead to gear failure.

2.1.7 Check brakes in gears

Check the brakes at the same time you check the gears.

If the brakes should not hold the required test load of +33% cable pull increase on single line and fully coiled drum, then they must be removed and the cause must be found. If the planetary gear is removed due to increased oil contamination, check the brakes at the same time.

CAUTION: Only expertly trained personnel may inspect gears and brakes!

2.1.8 Document completed inspection

The result of annual inspections and repair / reconditioning work, including all completed tasks, must be recorded by the expert or the trained service technician, if necessary, with note by the inspection station or specialty shop.

This documentation must be enclosed in the crane inspection booklet and must be recorded in the repeat inspection column.

2.2 Required measures to monitor the winches

2.2.1 Theoretical service life

When calculating and dimensioning the winches for your crane, the designer took certain operating conditions and a calculated total service life time into account, which determined a theoretical service life.

The winches in your crane are classified according to DIN report 1, ISO 4301/1 or FEM 9.511, as follows:

Drive group:	M3 (1 Bm)
Load collective:	Q1 (L1)
Factor of load collective k_m :	0.125
Theoretical service life D:	3200 hrs.

CAUTION: The "theoretical service life" may not be equated with the real (actual) service life of a winch!
If the crane is utilized in another way as was intended, then the user must carry out these calculations himself!

The real service life for a winch is influenced by many external matters, such as :

- Overloads, because the crane was not utilized as intended
- Insufficient maintenance: Oil has not been changed at the proper intervals
- Erroneous operation : extreme acceleration or deceleration of the load
Load fell into the cables
- Maintenance errors: Use of wrong oil
Wrong quantity
Contamination during oil change
- Installation errors during repair or maintenance
- Leakages which were not taken care of
- Improperly adjusted safety devices
- Hidden accident damage
- Extreme ambient conditions: Low or high temperatures
aggressive atmosphere
Dust and dirt

2.2.2 Used portion of theoretical service life

The crane operator is obligated to have the crane inspected at least once a year (ISO 9927-1 and VBG 8).

The used portion of the theoretical service life must also be determined. If necessary, the crane operator must call in an expert.

When determining the used portion of the theoretical service life, the actual operating conditions (load collective) and the operating hours of hoist gears per inspection interval must be determined. The user is responsible to have it documented in the crane inspection booklet.

2.2.2.1 Determining the operating conditions (Load collective)

The load collective of the crane is divided into groups; see also DIN report 1, ISO 4301/1 or FEM 9.511.

From the determination of the actual operating conditions, choose one of the following load collectives and enter them in the crane inspection book for the corresponding inspection interval.

Note: For mobile cranes in assembly operation, we normally use the load collective L1 (Q1), with the load collective factor $k_m = 0.125$.

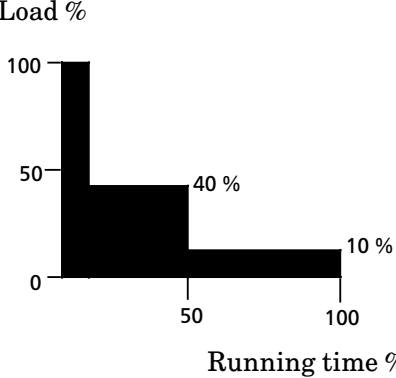
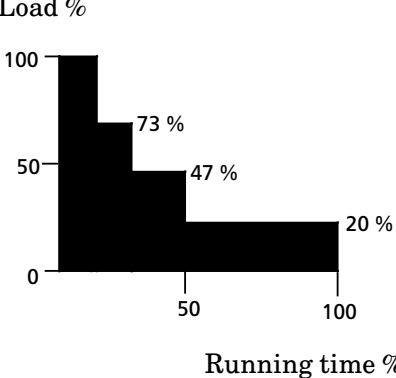
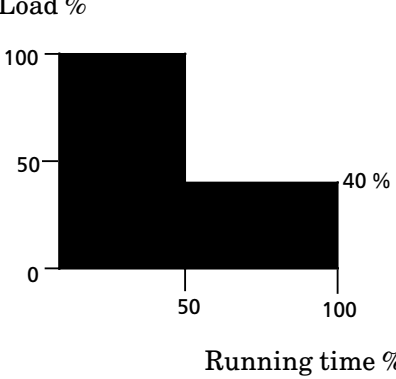
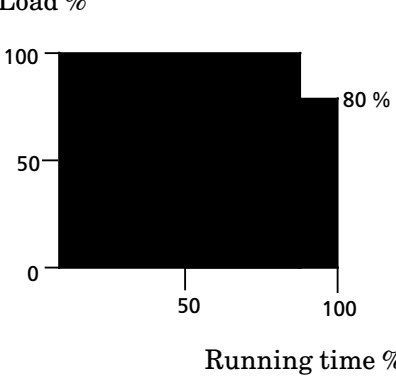
Load collective Classification	Definition	Service life portion	Factor of load collective	Graphic view
Light Q 1 L 1	Drive gear or parts thereof, which run only at high utilization in exceptional cases , but are subjected to constant, but only light duty	10 % of running time with largest load (dead load + 1/1 load capacity) 40 % of running time with dead load + 1/3 load capacity) 50 % of running time with only dead load	$k_m = 0,125$	 <p>A step chart showing the relationship between Running time % (x-axis, 0 to 100) and Load % (y-axis, 0 to 100). The chart consists of three horizontal bars: the first bar is at 100% load for the first 10% of running time; the second bar is at 40% load for the next 40% of running time; and the third bar is at 10% load for the remaining 50% of running time.</p>
Medium Q 2 L 2	Drive gear or parts thereof, which often run at high utilization, but are subjected to light duty	1/6 of running time with largest load (dead load + 1/1 load capacity) 1/6 of running time with dead load + 2/3 load capacity 1/6 of running time with dead load + 1/3 load capacity 50 % of running time only with dead load	$k_m = 0,25$	 <p>A step chart showing the relationship between Running time % (x-axis, 0 to 100) and Load % (y-axis, 0 to 100). The chart consists of four horizontal bars: the first bar is at 100% load for the first 1/6 (approx. 16.7%) of running time; the second bar is at 73% load for the next 1/6 (approx. 16.7%) of running time; the third bar is at 47% load for the next 1/6 (approx. 16.7%) of running time; and the fourth bar is at 20% load for the remaining 50% of running time.</p>
Heavy Q 3 L 3	Drive gear or parts thereof, which often run at high utilization, but are subjected to constant medium duty	50 % of running time with largest load (dead load + 1/1 load capacity) 50 % of running time only with dead load	$k_m = 0,5$	 <p>A step chart showing the relationship between Running time % (x-axis, 0 to 100) and Load % (y-axis, 0 to 100). The chart consists of two horizontal bars: the first bar is at 100% load for the first 50% of running time; the second bar is at 40% load for the remaining 50% of running time.</p>
Very heavy Q 4 L 4	Drive gear or parts thereof, which regularly run at high utilization, and are subjected to constant heavy duty	90 % of running time with largest load (dead load + 1/1 load capacity) 10 % of running time only with dead load	$k_m = 1$	 <p>A step chart showing the relationship between Running time % (x-axis, 0 to 100) and Load % (y-axis, 0 to 100). The chart consists of two horizontal bars: the first bar is at 100% load for the first 90% of running time; the second bar is at 80% load for the remaining 10% of running time.</p>

2.2.2.2 Determining the effective operating hours T_i

The effective operating hours, as determined as follows, must be entered in the crane inspection booklet for the corresponding inspection interval, differentiated by the following 4 points:

2.2.2.2.1 Hour meter is on every winch

If your crane is equipped with an hour meter on every winch, then the effective number of operating hours T_i per inspection interval can be read directly.

2.2.2.2.2 Hour meter for the total crane operation

The winch operation portion of the total operating hours of the superstructure must be guessed.

Note: For mobile cranes in assembly operation, normally, when hoist winches are used, 20% of the total superstructure operating hours can be contributed to winch operation.

2.2.2.2.3 Hour meter for both travel and crane operation

The winch operation portion of the total operating hours of the superstructure must be guessed.

Note: For mobile cranes in assembly operation, normally, 60% of the total operating hours can be contributed to superstructure operation. If 20% of the total superstructure operating hours can be contributed to winch operation (see paragraph 2.2.2.2.2), the result would be 12% of the **total** crane operating hours.

2.2.2.2.4 If there is no hour meter at all

In this case, the operator must guess and document the actual winch operating hours .

Note: The given percentage values apply normally for the main hoist winch. For auxiliary hoist winches or adjustable boom winches, the actual share of total operating hours can be significantly less and must therefore be guessed by the operator.

2.2.2.3 To determine the used portion of the theoretical service life

For an inspection interval i (max. 1 year after ISO 9927-1 or VBG 8), the used portion S_i of the theoretical service life is determined according to the following formula:

$$S_i = \frac{k_{mi}}{k_m} \times T_i$$

k_m = Factor of load collective, which was the basis when calculating the winch. This factor can be taken from the Operation Manual.

k_{mi} = Factor of load collective in the inspection interval i according to paragraph 2.2.2.1

T_i = effective operating hours in the inspection interval i according to paragraph 2.2.2.2

This used portion is taken off after each inspection interval from the remaining theoretical service life D_i (see example).

If the remaining theoretical service life is insufficient for the next operating period, then the winch must be reconditioned or overhauled.

When the theoretical service life D has been reached (see paragraph 2.2.1), then the winch may only be operated again after it has been reconditioned or overhauled.

In any case, it must be reconditioned or overhauled at the latest after 10 years after putting the crane into service.

The general reconditioning or overhaul must be initiated by the operator and must be done by the manufacturer or by a person authorized by the manufacturer and the overhaul must be documented in the inspection booklet.

After the general reconditioning or overhaul, the manufacturer or the person authorized by the manufacturer will note a new theoretical service life D .

In any case, the maximum time frame to the next general overhaul is max. 10 years.

2.2.3. Example

According to the Operation Manual, a mobile crane with separate hour meter for travel drive and crane operation is classified by the manufacturer as follows:

Drive gear group:	M 3
Load collective:	light L1, $k_m = 0.125$
Theoretical service life:	$D = 3200$ hrs.

The used part S of the theoretical service life can be calculated for the individual inspection intervals as follows:

1st Inspection (1st year)

The crane has been utilized during the past year for assembly work:
Load collective L1, which means $k_{m1} = 0.125$.

The superstructure hour meter read 800 hrs. Winch operation was about 20 % of that, which means $T_1 = 160$ hrs.

At the 1st inspection, the used part S of the theoretical service life is therefore as follows:

$$S_1 = \frac{0.125}{0.125} \times 160 \text{ hrs} = 160 \text{ hrs.}$$

remaining theoretical service life:

$$D_1 = 3200 \text{ hrs} - 160 \text{ hrs.} = 3040 \text{ hrs.}$$

The above values are entered in the chart in the crane inspection booklet, see paragraph 2.2.4)

2nd Inspection (2nd year)

The crane has been utilized for unloading ships in the harbor:
Load collective: L3, which means $k_{m2} = 0.5$

The superstructure hour meter read 2000 hrs, which means during this period:
2000 hrs. - 800 hrs. = 1200 hrs. (800 hrs. were used in the first year of operation)

Of that, the winch was used about 40 %, which means $T_2 = 480$ hrs.

The used portion S_2 of the theoretical service life can be calculated for the 2nd individual inspection interval as follows:

$$S_2 = \frac{0.5}{0.125} \times 480 \text{ hrs.} = 1920 \text{ hrs.}$$

remaining theoretical service life:

$$D_2 = 3040 \text{ hrs.} - 1920 \text{ hrs.} = 1120 \text{ hrs.}$$

3rd Inspection (3rd year)

The crane has been used for assembly work and sometimes for unloading work in the harbor:
Load collective: L2, which means $k_{m3} = 0.25$

The superstructure hour meter reads 3000 hrs, which means that during this period:
3000 hrs. - 2000 hrs. = 1000 hrs. (2000 hrs. were used up in the first two years of operation)

Of that, the winch was used about 30 %, which means $T_3 = 300$ hrs.

The used portion S_3 of the theoretical service life can be calculated for the 3rd individual inspection interval as follows:

$$S_3 = \frac{0.25}{0.125} \times 300 \text{ hrs.} = 600 \text{ hrs.}$$

remaining theoretical service life:

$$D_3 = 1120 \text{ hrs.} - 600 \text{ hrs.} = 520 \text{ hrs.}$$

The above values are entered in the chart in the crane inspection booklet as shown in chart 1.

2.2.4. Addendum

Chart 1 shows an example.

Document the remaining theoretical service life on chart 2.

Chart to determine the remaining theoretical service life of winch No. 1 (Main hoist winch)

Crane type: LTM 1050
 Fabrication No.: 0010 540 08
 Put in service : 12345
 Serial number of winch according to data tag: 0815
 Last general overhaul performed on:
 Configuration data of winch (see Operating Manual):
 Drive gear group: M 3
 Load collective: Q 1 (L1)
 Factor of load collective k_m : 0.125
 Theoretical service life D: 3200 hrs.

S_i = Used part of theoretical service life since last inspection
 D_i = Remaining theoretical service life
 D_{i-1} = Remaining theoretical service life after previous inspection
 k_m = Factor of load collective, which was taken for calculation of winch.
 This factor is to be taken from the Operating Manual
 k_{mi} = Factor of load collective in inspection interval i according to paragraph 2.2.2.1
 T_i = Effective operating hours in inspection interval i according to paragraph 2.2.2.2

Inspection No.	Date of initial service, data of inspection	Operating conditions since last inspection (load collective)	Factor of load connective	Total crane operating hours	Operating hours of super-structure	Operating hours of super-structure since last inspection	Operating hours of winch	Operating hours of winch since last inspection T_i	Used part of theoretical service life D: $S_i = \frac{k_{mi}}{k_m} \times T_i$	Remaining theoretical service life $D_i = D_{i-1} - S_i$	Name of inspector	Signature	Remarks
i			k_{mi}	[h]	[h]	[h]	[h]	[h]	[h]	[h]			
0	10.06.90	-	-	-	0				0	3200			
1	05.06.91	L1	0,125	-	800	800	-	160 (20 % of 800)	160	3040	Müller		
2	20.05.92	L3	0,5	-	2000	1200	-	480 (40 % of 1200)	1920	1120	Huber		
3	18.05.93	L2	0,25	-	3000	1000	-	300 (30 % of 1000)	600	520	Maier		

CAUTION: Perform general overhaul at least once every 10 years.
 General overhaul last performed on :

Chart to determine the remaining theoretical service life of winch No.

Crane type:
 Fabrication No.:
 Put in service:
 Serial number of winch according to data tag:
 Last general overhaul performed on:
 Configuration data of winch (see Operating Manual):
 Drive gear group: M.....
 Load collective: Q.....(L.....)
 Factor of load collective k_m :
 Theoretical service life D:

S_i = Used part of theoretical service life since last inspection
 D_i = Remaining theoretical service life
 D_{i-1} = Remaining theoretical service life after previous inspection
 k_m = Factor of load collective, which was taken for calculation of winch.
 This factor is to be taken from the Operating Manual
 k_{mi} = Factor of load collective in inspection interval i according to paragraph 2.2.2.1
 T_i = Effective operating hours in inspection interval i according to paragraph 2.2.2.2

Inspection No. i	Date of initial service, data of inspection	Operating conditions since last inspection (load collective)	Factor of load connective k_{mi}	Total crane operating hours [h]	Operating hours of super-structure [h]	Operating hours of super-structure since last inspection [h]	Operating hours of winch [h]	Operating hours of winch since last inspection T_i [h]	Used part of theoretical service life D: $S_i = \frac{k_{mi}}{k_m} \times T_i$ [h]	Remaining theoretical service life $D_i = D_{i-1} - S_i$ [h]	Name of inspector	Signature	Remarks

CAUTION: Perform general overhaul at least once every 10 years.
 General overhaul last performed on :

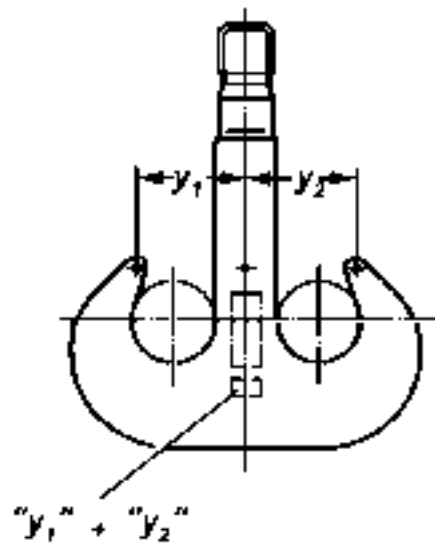
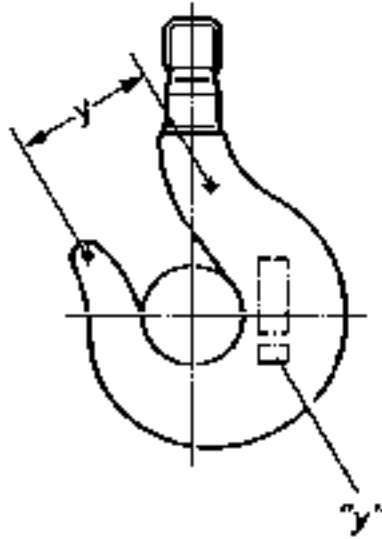

3. Inspection of load hook

The load hooks must be regularly checked by an expert.

These inspections are made to prevent accidents through early detection of problems.

Any problems found during these inspections must be documented, remedied and then reinspected .

3.1 Inspections and monitoring procedures**3.1.1 Distortion**

Check for any distortions, for example on the open end of the hook, regularly, but at least on an annual basis.

The open end of the hook may not have stretched by more than 10% in relation to the initial measurement "y" or exceed "y1" and "y 2".

D A N G E R : If the hook opening is now wider by more than 10 % of the initial measurement, then the load hook may no longer be used.
In that case, contact the Service Department at Liebherr Ehingen .

Note: The initial measurements "y" or "y1" and "y2" are noted on the load hook. Measure from point to point, as shown.

3.1.2 Corrosion

For this test, the nut must be removed from the hook shaft, so that the threads can be checked for corrosion and wear.

D A N G E R : In case corrosion and wear is found on the threads, the load hook may no longer be used.
In that case, contact the Service Department at Liebherr Ehingen .

4. LIEBHERR special regulations**4.1 Check the cable push out mechanism in the telescopic boom .****4.2 Check the inner and outer locking systems on the telescopic boom for function, pin set up, wear and safety control.****4.3 Check the safety control or the limit switch in the relapse support and the boom A-brackets.****4.4 Check the nitrogen reservoir for correct gas pressure in oil pressure - zero pressure condition, especially that of the relapse supports and suspension accumulators (observe instructions).****4.5 The cable pulleys must be checked once a year all around for damage and cracks. If the cable pulleys have been hit during crane operation (for example on buildings, etc.) or if they were subjected to any other stress factors, then they must be extensively checked for damage or cracks.**

D A N G E R : If any damage or cracks are found, then the cable pulley must be replaced immediately. If this is not observed, there is great danger of causing a serious accident!

Discard time for wire cables due to broken wires.

Torsion free cables

Hoist cable I, Hoist cable II

Crane type	Cable Ø [mm]	Cable turn	Number of carrying wires in outer strands	Number of visible broken wires at time of discard over a length of	
				6 × Cable Ø	30 × Cable Ø
LTM 1030/1	13	Even lay	105	2	5

Non torsion free cables

Telescoping cable I

Crane type	Cable Ø [mm]	Cable turn	Number of carrying wires in outer strands	Number of visible broken wires at time of discard over a length of	
				6 × Cable Ø	30 × Cable Ø
LTM 1030/1	16	Cross lay	208	9	18

Telescoping cable II

Crane type	Cable Ø [mm]	Cable turn	Number of carrying wires in outer strands	Number of visible broken wires at time of discard over a length of	
				6 × Cable Ø	30 × Cable Ø
LTM 1030/1	14	Cross lay	208	9	18

Back pull cable I

Crane type	Cable Ø [mm]	Cable turn	Number of carrying wires in outer strands	Number of visible broken wires at time of discard over a length of	
				6 × Cable Ø	30 × Cable Ø
LTM 1030/1	13	Cross lay	152	6	13

Back pull cable II

Crane type	Cable Ø [mm]	Cable turn	Number of carrying wires in outer strands	Number of visible broken wires at time of discard over a length of	
				6 × Cable Ø	30 × Cable Ø
LTM 1030/1	12	Cross lay	152	6	13

Monitoring

The cables must be checked regularly, especially strict during the first initial period after placing them, in addition to the time after they have been exposed to unusual strains, if there might be any damage which is not clearly visible or after the first signs of cable damage show up.

The operating safety of cables can be determined according to the following criteria:

- Type and number of broken wires (see chart)
- Position and time frame of broken wires
- Reduction of cable diameter during operating time
- Corrosion, chafing, cable distortion
- Heat effects
- Total placement time

In addition, cable end connections and cable suspension must be regularly checked for proper condition. The individual elements of the cable drive, cable drums and pulleys must easily rotate in their mounts and they may not show an impression of the cable profile in their tracks.

Note: The groove radius on drums and pulleys must be at least $0.53 \times$ rated cable diameter.

Any changes in cable behavior must be especially well monitored.

DANGER: As soon as the cable strands hit together above the hook block, there is a danger of serious cable damage. The cause is always added revolution tension in a torsion free hoist cable, which can be due to a variety of influences and problems, but also due to special stress or extension of the hoist cable in severe applications.

Note: Refer to the paragraph describing "Extension torsion in torsion free hoist cables and its elimination"

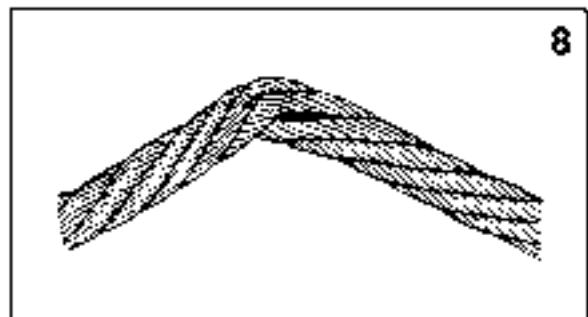
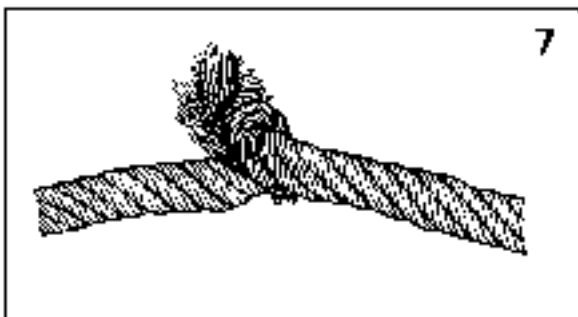
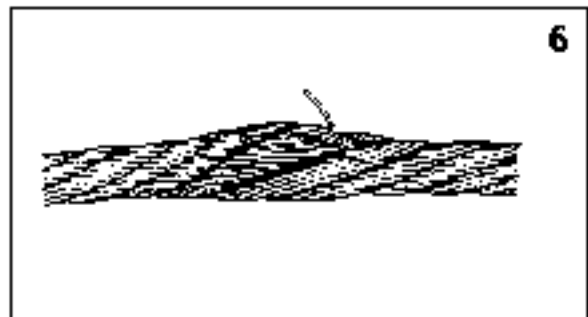
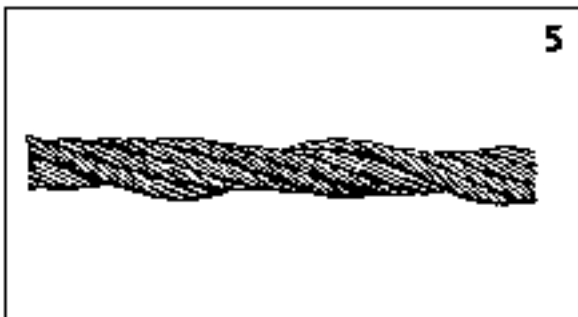
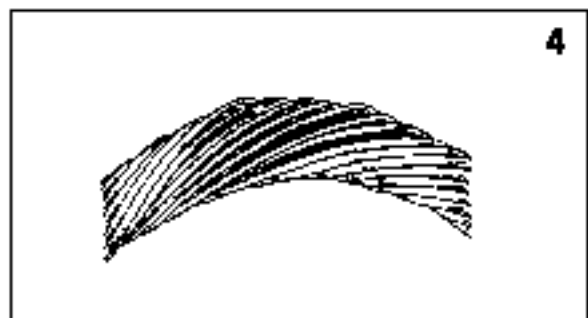
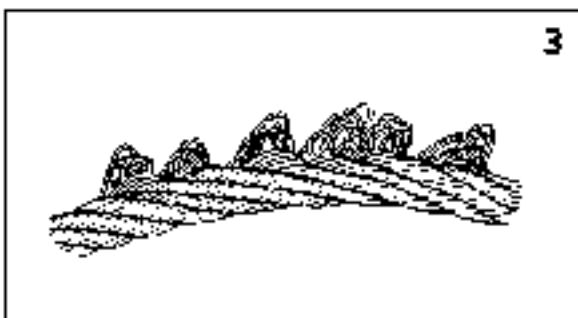
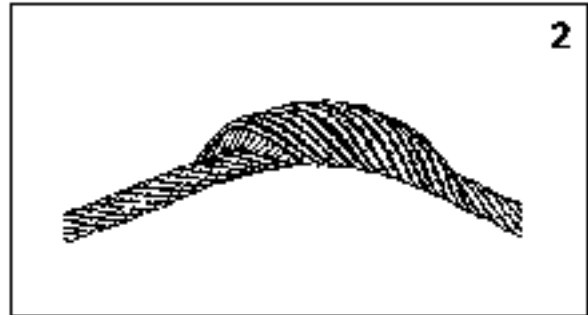
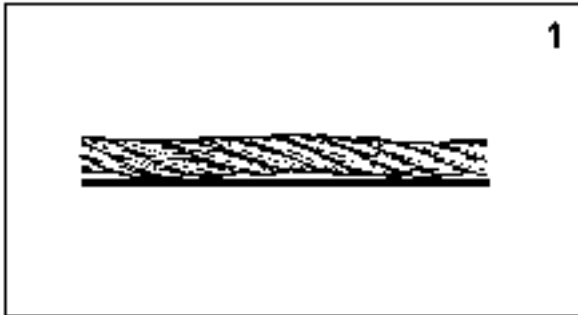

Discard time

DANGER: The cables must be discarded immediately if one of the following problems is found:

- Break of a strand
- Occurrence of wire break pockets
- Reaching the wire break numbers according to the chart
- Corkscrew type deformations by more than 1/3 of the cable diameter (fig. 1)
- Arch formation (fig. 2)
- Hair pin shaped penetration of wires or wire strands from the cable (fig. 3)
- Reduction of cable diameter as compared to the nominal diameter by more than 15% or by 10% with simultaneous occurrence of corrosion and / or abrasion (fig. 4)
- Slackening of cable structure (fig. 4)
- Constriction (fig. 5)
- Kinks and compressions (fig. 6 + 8)
- Pulls or remaining distortions (fig. 7)

If particular cable damages occur, you must find the cause for these damages and remedy them before placing a new cable.

The damages and grinding traces on the construction parts of the crane can provide important clues.

CAUTION: If there are doubts if the crane cable is still operational safe, then put it down or consult an expert for an opinion.

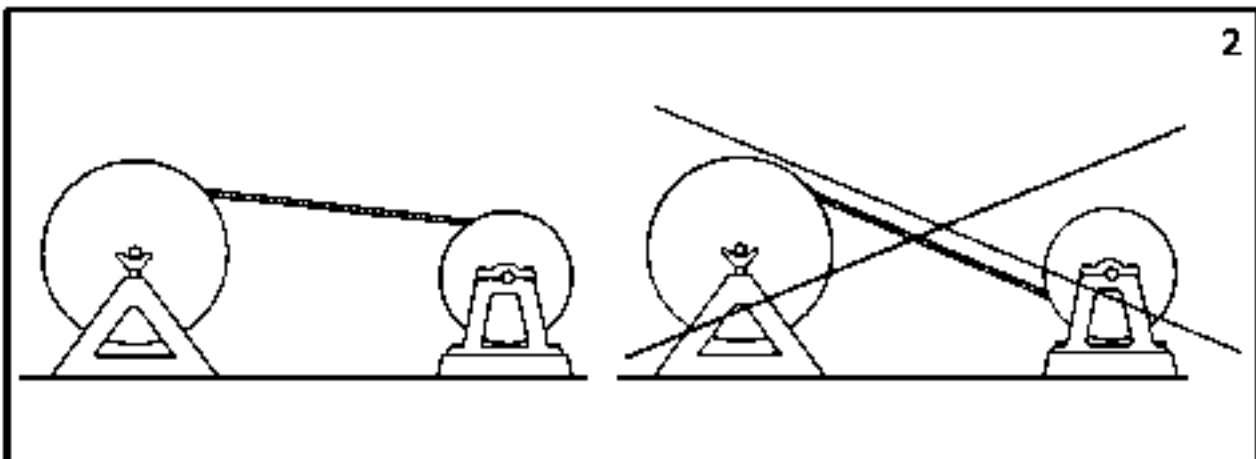
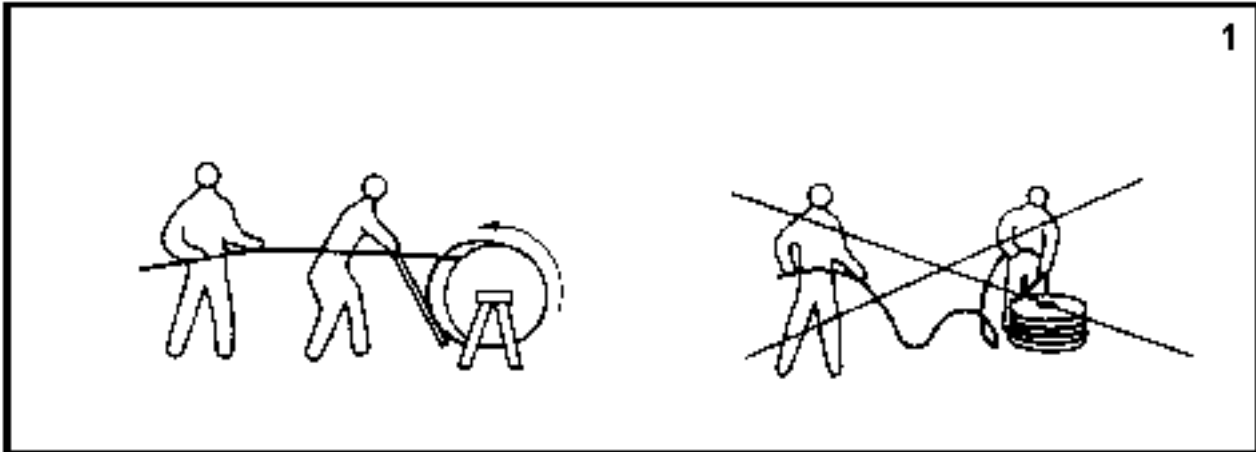

Place the cable

DANGER: If a cable is changed, you must use a cable of the same type and solidity with the same diameter as the original cable had when it was new.
If another wire cable is to be used, you must first get the approval of the crane manufacturer.

Cables are very susceptible to external damage. Be especially careful when placing them for transport and / or when they are unloaded.

Any cables held in reserve must be stored in a clean, cool and dry area. Be sure that they don't lay on soil.

Cables can only work properly without any problems if they are without any twists or other external damage.

Winding procedure

Cables must be pulled in winding direction from the reel or the ring (fig. 1).

Do not pull off the cable sideways, because that will cause the cable to twist and will cause pulls which will destroy the cable.

The best procedure is to spool up the cable from a raised reel to the drum (fig. 2).

Winding the cable in the same bending direction prevents additional cable tension and assures that the cable lays better on the drum.

CAUTION: Make sure that the cable is not pulled over the ground to prevent it from getting dirty.

A swivel must be interconnected to protect torsion free hoist cables from forced twists.

If multiple layers are wound, the lower layers must be wound tightly with a pretension of about 1 to 2% of the minimum braking force of the cable. This pretension can be reached by slowing down (braking) the reel.

For multi-sheave reeving, the hoist cable should be reeved at the same direction as it has in the drum. If a limited cable length to reeve the hook block must be laid on the ground, then it must be assured that the cable is not twisted.

After placing the cable, test it first with low partial loads and then retract it in several hoists, switching between a loaded and an unloaded hook block. This ensures that the cable adapts to the bending direction and the bending radius of pulley and drum.

Maintenance and care

Regular cable maintenance assures the operating safety of the crane and significantly increases the service life of the cable.

Wire cables must be lubricated in regular intervals, depending on the operating conditions, especially in the area where the cable bends on drums and pulleys.

It was determined that under the same test conditions well lubricated cables provide 4 times more bending flexure than unlubricated cables.

The lubricants must be compatible with the original cable lubricant .

Note: The cables must be lubricated with standard, commercially available lubricants, as recommended by the crane manufacturer. Refer to the lubrication chart.

Dirty wire cables should be cleaned regularly, preferably with brushes.

If the lower cable layers on the drum are hardly used or used not at all, then they should be unwound from time to time and rewound with pre-tension. A cable is most economical when it is used in its entire length. For that reason, for longer lasting crane work, it is recommended to match the cable length to the task.

If certain section of the cable are more used than others then the cable should be turned over after a certain time. Service life of the cable can be increased significantly by attaching the previously free end to the drum, and sections which were previously spared are now used more severely and areas which were previously used more will now not be used as much.

If wear is predominantly in multi-layers on the Lebus drum, then the service life of the cable can be increased by shorting the drum end by a length which corresponds to 1/3 of the drum circumference.

Extension torsion in torsion free hoist cables and its elimination

A torsion compensation is not only required after a new cable has been placed, but also if extension torsion has been building up after a longer working period, resulting from stretching and settling of the cable structure.

Torsion compensation can be noticed when the hook block turns in multi reeve operation and when **the load is set down and / or the outer strands seem to loosen up and if, in extreme cases, the cable shows an arch formation.**

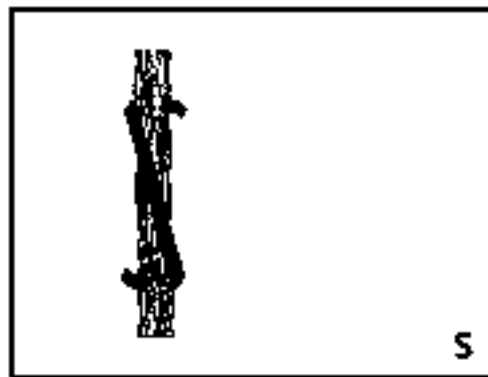
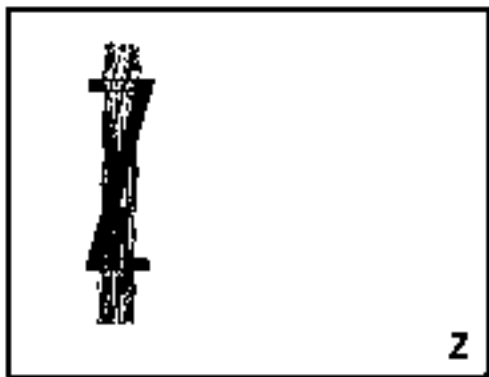
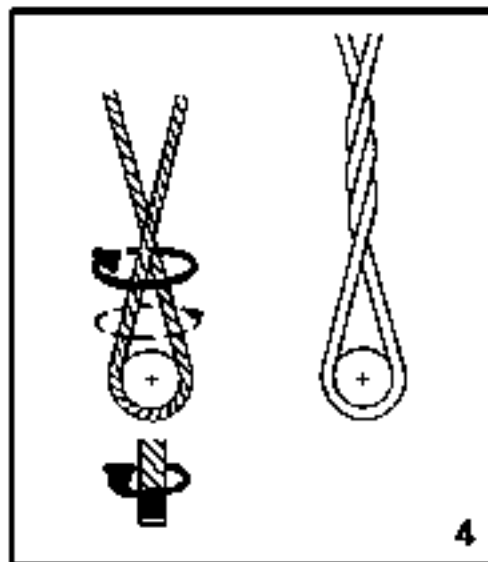
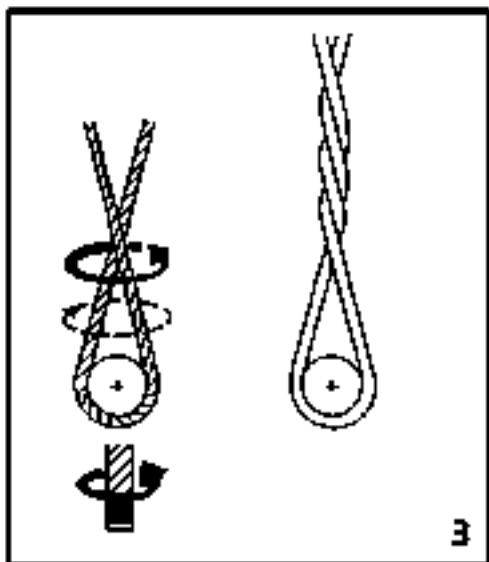
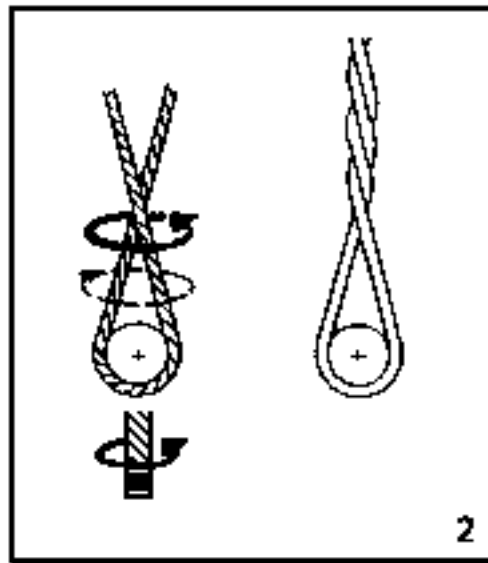
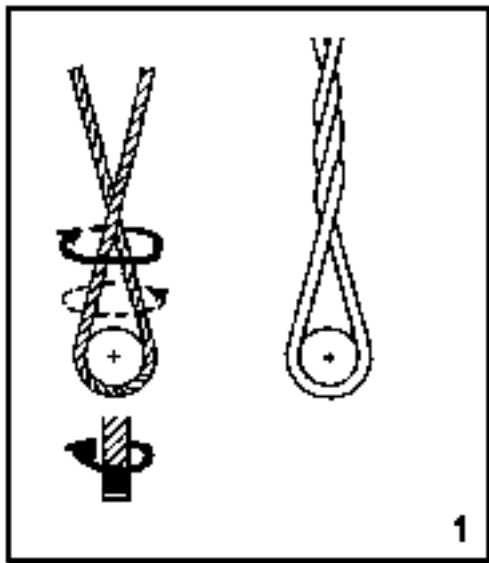

Measures to eliminate torsion compensation:**1 Set down the hook block**

Lower the hook block as much as possible, so that the greatest cable length between pulley head and hook block is exposed to compensation (twist, point 4).

2 Determine the turning direction

First determine in which direction the hook block is twisted.

The turning directions are shown on the illustration with a continuously lined arrow.

Since this is difficult, especially in large hoisting heights, check it by turning in direction of the dashed arrow. The "braid" must dissolve.

3 Loosen the cable on the fixed point

When the direction of rotation has been determined, release the cable on the fixed point on the hook block.

Note: It is advantageous if, for torsion compensation, the hook block has been reeved in an uneven number or that such a number will be reeved.
In that case, the fixed point of the cable is easily accessible on the hook block and it can easily be released.

4 Carefully turn the end of the cable by 180° to 360°, to compensate for the turn of the hook block

To compensate for the turn, turn the separately shown end of the cable, as marked by the solid line arrow.

Note: It is important that the correct reference point is taken and that the crane operator holds the cable in front of him .

The right moving cable (**Z**), as shown in fig. 1 and the left moving (**S**) cable, as shown in fig. 4, is turned in for compensation, while the right moving cable (**Z**), as shown in fig. 2, and the left moving cable (**S**), as shown in fig. 3, must be turned out.

The rule is that for torsion compensation, the end of the cable must be turned against the direction of rotation, which caused the release of the "braid" in the above test.

CAUTION: The cable section should be as long as possible for the turn. Through a hoisting movement without a load, this turn should be distributed over the complete length of the cable.

Under no circumstances turn the cable by force over a short section, because this would destroy the cable structure permanently.

5 Reattach the cable on the fixed point

The end of the cable must be reattached and secured on the fixed point after the turn.

6 Carefully lift the hook block, raise it without a load and repeat the procedure, if necessary

Since a non-stretch cable construction is relatively safe from torsion, the cable can only be stretched a little (actually, the torsion does not continue over the cable pulley), so that the hoisting movements with out a load must be repeated several times.

After getting the compensating turn to the end of the cable, reattach the cable end again to the fixed point and repeat the hoisting movements with out a load one or several times so that the torsion compensation can be distributed over the complete length of the cable past the cable pulley.

Note: If necessary, in case the stretch was especially severe (multiple twisting of the lower pulley block and / or slackening of outer strands over a longer stretch, or at several points) then repeat this procedure several times, depending on hoist cable length.

General

The pneumatic brake system in mobile cranes must be checked annually.
In Germany, this brake inspection must be made according to § 29 STVZO.
For other countries, local and national regulations apply.

1. Visual inspection

To check the pneumatic brake system, the following requirements apply:

- 1.1 Pipe and hose lines are not damaged, not corroded and are properly routed.
- 1.2 Components are correctly installed and properly mounted.
- 1.3 Air tank is not damaged, no external corrosion can be seen.
The tank is marked properly.

CAUTION: No welding nor heat applications may ever be done on the tank walls .

- 1.4 Condensation is drained from the air tank.
- 1.5 Dust guards are not damaged.
- 1.6 Joints are secured, move easily and have not been knocked out.
- 1.7 Linkage has not been welded, is not bent, moves easily and is not damaged.
- 1.8 Brakes are adjusted properly (ventilation, brake cylinder stroke, pad thickness, linkage plate).

2. Function and action test**2.1. Function test**

- 2.1.1 Pressure regulator , air compressor
Check cut in pressure, cut off pressure and output capacity.
- 2.1.2 Check seals and reservoir pressure in air pressure system.
- 2.1.3 Check multi circuit safety valve, overflow valves, warning device.

2.2 Brake action test

The brake function can be checked through the ports in the cover plates.

If the brake pedal is pressed down, both brake pads must touch the drum, when the brake pedal is released, the brake pads must immediately return to starting position.

The brake action can be checked by measuring delay, brake path or by determining the braking action on a brake test station.

2.2.1 Measure the delay with a decelerometer

At a pressure of 6.5 bar, the measured median delay should be $d_m > 4,5 \text{ m/s}^2$.

2.2.2 Measure the brake path

At a pressure of 6.5 bar, the brake path should be $s <$ as the value given in the chart.

Test speed v [m/s]	Brake path s [m]
20	6.5
30	12.5
40	19.8
50	29.0

2.2.3 Determine braking action on a brake test station

To measure the brake power on the vehicle axles, calculate the braking action as follows:

$$z = \frac{F_1 \times i_1 + F_2 \times i_2 \dots F_n \times i_n}{G_z} \times 100 [\%]$$

G_z = Permissible total weight of the vehicle [N]

z = Braking [%]

F_1 = Brake power of first axle, which has been measured at p_1 pressure [N]

F_2 = Brake power of second axle, which has been measured at p_2 pressure [N]

F_n = Brake power of last axle, which has been measured at p_n pressure [N]

$$i_1 = \frac{p_{N1} - 0,4}{p_1 - 0,4}$$

$$i_n = \frac{p_{Nn} - 0,4}{p_n - 0,4}$$

$p_{N1} \dots n$ = maximum brake pressure of corresponding axle [bar]

$p_{1 \dots n}$ = Brake pressure, which is used [bar] at the brake test in the wheel cylinder of the corresponding axle

3. Internal inspection of wheel brake

Independent of the function and action test, the following tests must be made:

- 3.1 Every 3 months, the brake pad condition should be checked through the ports in the cover plates. Every 12 months, pull the brake drum to check the various, internal brake components .

C A U T I O N : **The brake may not be actuated if the brake drum has been pulled.**

- 3.2 Replace the pads when the pad thickness is 5.5 mm (new thickness = 18 mm), measured without taking the thickness of the metal part of the brake pad into account; replace the pads if the pads are burnt, slick or oily.

For replacement, only **Jurid 546** and **Bremskerl 6275** brake pads may be used.

Rivet and adhere these pads, as these asbestos free pads are not as rigid.

D A N G E R : **Always replace the pads on both wheels of each axle.**

- 3.3 The brake drums should also be turned.

Note: When turning the brake drums, do not exceed the permissible turning measurement of 0.75 % of the nominal diameter!

Example:	Nominal diameter:	500.00 mm
	Permissible turning measurement:	3.75 mm
	Permissible inside diameter:	503.75 mm

D A N G E R : **If the inside diameter of the brake drum is larger than 503.75 mm, then the brake drum must be replaced.**

Otherwise there is a danger of causing a serious accident!

- 3.4 To correct the brake pad wear or to center the brake, it is equipped with an automatic adjustment device, which is maintenance free.

D A N G E R : **In case of damage to any parts, replace the automatic adjustment device completely, using repair kit "adjustment device".**

If this is not done, there is a danger of causing a serious accident!

- 3.5 The pressure and pull springs as well as seal rings, caps and dust covers must be replaced at least every 2 years.

D A N G E R : **All maintenance and repairs on th brake system must be performed by authorized and especially trained personnel.**

Otherwise there is a danger of causing a serious accident!

- 3.6 After assembly, repeat visual, function and action test.

Chapter 9

General Notes

Issued by: VDMA (association of german mechanical- and plant engineers) - January 1970

The telescopic boom crane which has been supplied to you is equipped in conformity with the Accident Prevention Regulations Relating to Telescopic Boom Cranes with an overload safety device (overload motion cut device) by means of which the hoist and the telescoping gear are switched off if the maximum permissible load moment of the crane is exceeded. It must still be possible, after the overload safety equipment has been activated, to perform the opposite movement in order to reduce the crane load, in other words, it must still be possible to lower the load after the hoist has been switched off.

Installation of an overload safety device (overload motion cut device) is intended to prevent loads being lifted with the crane which jeopardise the crane's stability. The overload safety device (overload motion cut device) is thus an emergency switch which switches off any movement which increases the load moment of the crane once the crane has been overloaded and thus prevents a possible accident or damage or injury to persons or property.

It is essential to observe a number of points in order to ensure that the overload safety device is able to perform its safety function:

1. Overload safety devices (overload motion cut devices) must not be used in normal operations for switching off the hoist or the telescoping gear. The crane operator is required to satisfy himself that lifting the load will not exceed the specified maximum lifting capacity of the crane prior to performing the lifting operation. Excessively heavy loads, which are in excess of the load lifting capacity of the crane, must not be lifted even though an overload safety device is fitted. This safety device must not be used as a means of checking the weight of the load to be lifted and the crane must not be loaded beyond its safe working load.
2. Duties involving freeing stuck loads may only be performed with the prior approval of the crane manufacturer and only using such cranes as are properly equipped for such duties. If the crane is used for such duties, the overload safety device (safe load limiter) must not be used as a means of measuring the force.
3. The overload safety device fitted requires to be inspected and serviced at regular intervals and an operational check should be performed each time before crane operations are commenced. A regular inspection of the overload safety device is an integral part of the crane maintenance procedures in conformity with the Accident Prevention Regulations for Telescopic Boom Cranes.
4. The overload safety device does not normally adjust automatically to the different operating states of the crane. It is therefore the responsibility of the crane operator to also correctly set the overload safety device to the altered lifting capacity or load moment range when the crane is to be used for different duties. The instructions given in the manufacturer's operating manual in this connection should be strictly observed.

Strict adherence to these instructions is essential to ensure proper operation of this safety device and to ensure safe operation of the crane. An overload safety device which is incorrectly set, e.g. set to an excessively large load moment with the outriggers retracted, is a far greater hazard than a crane not fitted with such a device because this gives the crane operator a false sense of security, which in turn can be the cause of a serious accident.

5. The crane operator is required to set the overload safety device (overload motion cut device) which is fitted to the crane to the altered lifting capacity or load moment range when the crane is to perform different duties, for instance:
- a) when extending or retracting the outriggers (switching over to large or small load moment)
 - b) when altering the boom length by
 - manually extending or retracting (telescoping)
 - fitting or dismantling intermediate sections
 - c) when turning or slewing the crane into the range of the greater or lesser moment of stability (changing over to the large or small load moment)
 - d) when changing over to a different lifting capacity range by reeving the hoist or the telescopic gear with several falls
- 6) Attention is expressly drawn to the fact that the overload safety device may not be activated or the gear may not be switched off quickly enough if the crane is incorrectly operated. In such cases, it is not possible to completely rule out an accident despite an overload safety device being fitted. This is particularly true for
- hooking the load or the lifting tackle from below
 - excessive braking forces
 - loads dropping into the rope
 - pulling at an angle
 - moving the crane to an area of ground with a greater slope
 - ground which gives way
 - wind load
- 7) If a device is provided which enables the overload safety device (safe load limiter) to be switched off or overridden, this may only be used if special safety measures are taken and in the presence of a crane supervisor, e.g. when conducting a test of the crane, and when performing the duties specifically authorised by the crane manufacturer.
On no account may the overload safety device be switched off or overridden in order to lift a load which exceeds the maximum permissible load lifting capacity of the crane.

Careful observance of the instructions contained in this Code of Practice and in the operating manual of the crane manufacturer are essential requirements for safe and reliable operation of the overload safety device (overload motion cut device). If there is any doubt, the manufacturer's operating instructions should be consulted. If the information contained therein is not sufficient, it is essential to contact the company concerned. Unauthorized interference in the mechanism of the overload safety device will invalidate the warranty provisions.

1. Inspections

- 1.1 Check the engine area daily before starting the crane, and check all oil and fuel lines for leaks and make sure they are dry. In addition, check the fuel and oil filter as well as the injection pump for leaks.
- 1.2 During the daily check up, also check all hydraulic components, the hydraulic motors for the fan drives and corresponding hydraulic lines to assure that they are tight and that there are no leaks.
- 1.3 Check the exhaust system, especially the exhaust flange and the exhaust flap brakes to assure that they are not leaking and are easily movable. The return springs to open the exhaust flaps must be functioning properly, as stuck and therefore closed exhaust flaps during engine operation cause great increases in temperatures and overheating.
- 1.4 Check if electrical lines are still routed and mounted properly, with sufficient distance to exhaust pipes, and assure that they are not damaged and still properly insulated.
- 1.5 To reduce the noise emission, insulating mats are installed in the engine area (chassis - engine covering) on some crane models. When the fiberglass mats with integrated noise reduction material are clean, they are not flammable and are flame retardant.
If engine compartments are not cleaned regularly, oil and fuel may splash on the mats while performing maintenance and repair work. Oil and fuel soaked noise reduction mats must be removed, as they are now flammable. The same is true for insulating mats in the exhaust system area.

Clean the engine compartment only with nonflammable cleaning fluids. In addition, the fluid may not be corrosive or chemically damaging to hoses and cables.

2. Care during repair and maintenance work

- 2.1 When changing fuel and oil filters, make sure to observe utmost cleanliness. Remove any spilled fuel or oil promptly. Perform a test run to check the system for leaks.
- 2.2 Check the Diesel engine compartment regularly, especially after repairs and service work to assure that there is no oil or fuel residue. Spilled fuel in the V-section of the engine compartment can distribute throughout the whole engine compartment and could catch fire when it comes in contact with hot spots.
- 2.3 We want to note again that all electrical lines must be routed properly and clamped securely. Make sure to check all electrical lines for chafings and brittle insulation and covering, all damaged lines must be replaced immediately. Replace and / or reroute improperly installed lines immediately.
- 2.4 Fuel and oil lines can dry out due to age and become brittle and porous. Replace any lines and hoses, which look porous, immediately. (Refer to guidelines regarding service life of hydraulic hoses)
- 2.5 Make sure not to step on any pipes, tubes and hoses when performing service and repair work. That also applied to fuel injector lines. If it is absolutely necessary to step on these areas to perform certain maintenance or repair tasks, make sure to cover the engine first with a board.

3. Important service work

- 3.1 Lubricate the drive shafts regularly and properly with grease specified by Liebherr to prevent the drive shaft from running hot.
- 3.2 Check the drive shaft screws regularly to assure mounting tightness.
- 3.3 Check the oil level in the gear and in the engine regularly. Replace any normal loss of oil. If an unusual amount of oil is missing, find and remedy the cause for the oil loss.

4. Notes for travel operation

CAUTION: DO NOT exceed the permissible engine speed in high gear, it could cause engine damage!

5. Rotating wheels

- 5.1 Tires used on crane vehicles are exposed to different loads and stresses, depending on the location of the wheels on the crane, such as:
- non - propelled steering and fixed axles.
 - propelled steering and fixed axles and
 - various wheel positions exposed to more or less load.

Depending on the type of the tire tread, tires often wear differently.

- 5.2 To assure that all tires wear equally, we recommend to rotate the tires as soon as a difference in tire wear is visible. We recommend to rotate the tires after 5,000 to 10,000 km.

Rotate the tires in crosswise direction (see illustration). In addition, select the new tire positions in such a way that tires with uneven tire wear are moved to positions where tires wore evenly.

These measures can influence driving comfort and tire wear in a positive way.

